

Title		
BLOCK DIAGRAM		
Size	Document Number	Rev
A	<Doc>	A4
Date:	Thursday, October 09, 2014	Sheet 1 of 8

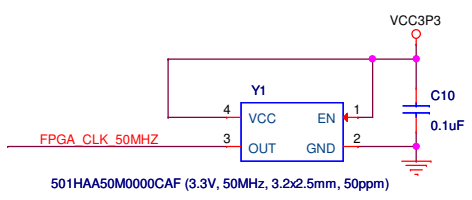

PMOD

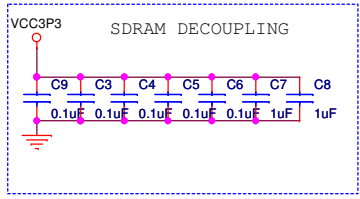
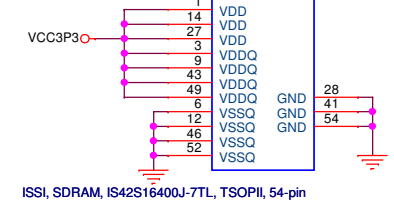
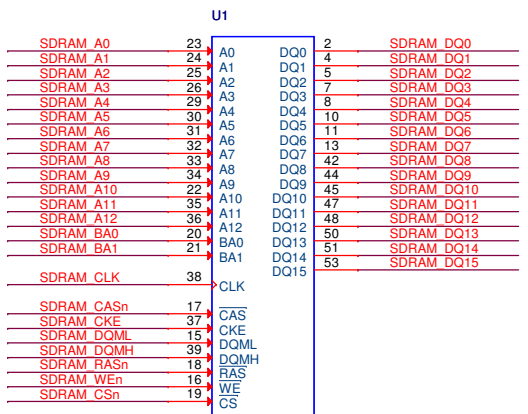
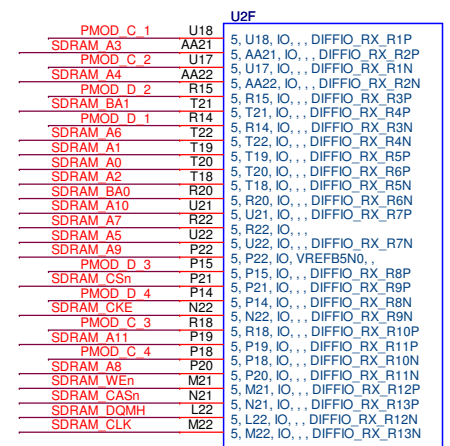
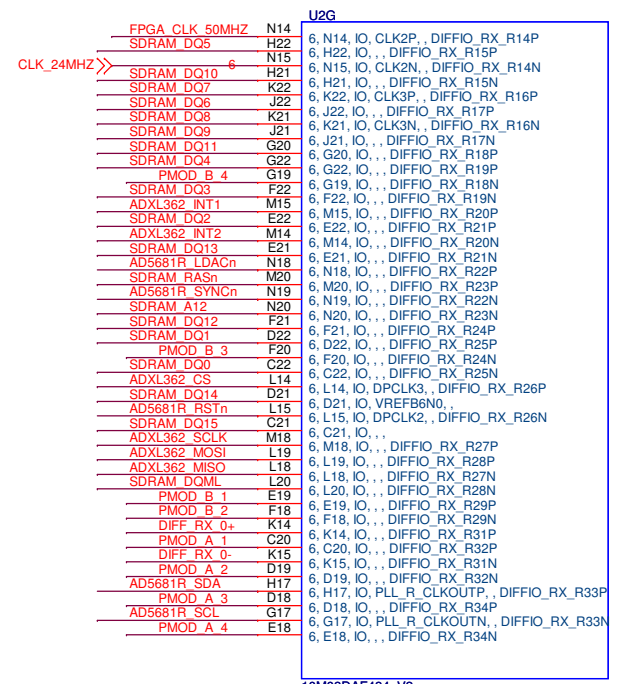
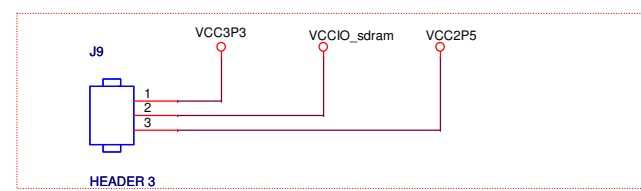
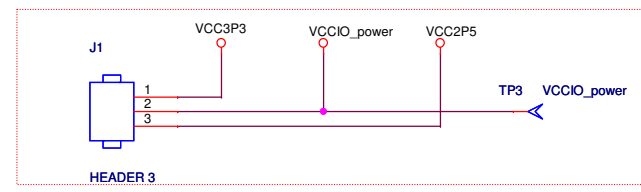
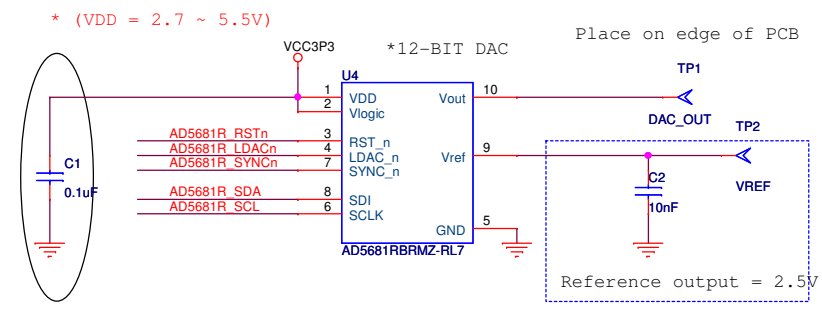
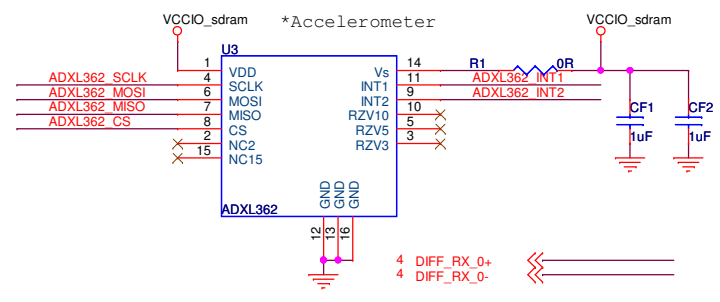
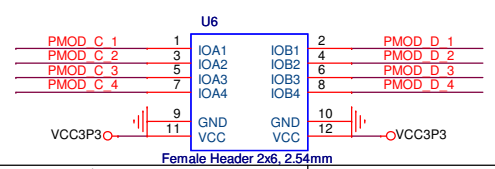
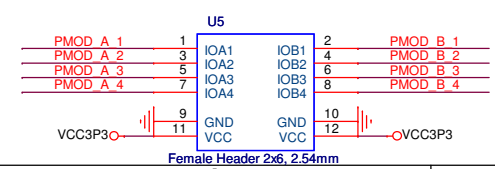

Title		
02 SDRAM		
Size	Document Number	Rev
B	<Doc>	A4
Date:	Thursday, October 09, 2014	Sheet 2 of 8

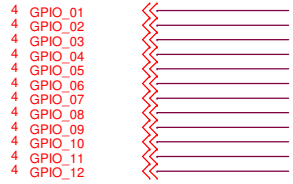
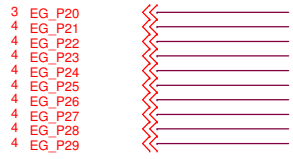
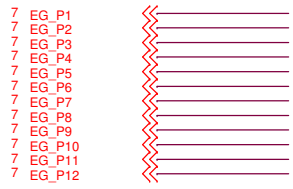

U21

EG P35	E11	8, E11, IO, , DIFFIO_RX_T12P
EG P43	C8	8, C8, IO, , DIFFIO_RX_T13P
EG P36	E10	8, E10, IO, , DIFFIO_RX_T12N
EG P44	C7	8, C7, IO, , DIFFIO_RX_T13N
EG P51	J10	8, J10, IO, , DIFFIO_RX_T14P
GPIO 11	B7	8, B7, IO, , DIFFIO_RX_T15P
EG P50	H11	8, H11, IO, , DIFFIO_RX_T14N
GPIO 12	A6	8, A6, IO, , DIFFIO_RX_T15N
EG P40	D8	8, D8, IO, , DIFFIO_RX_T16P
GPIO 10	A5	8, A5, IO, , DIFFIO_RX_T17P
EG P37	D9	8, D9, IO, , DEV_CLRN, DIFFIO_RX_T16N
GPIO 08	A4	8, A4, IO, , DIFFIO_RX_T17N
EG P46	D10	8, D10, IO, , DEV_OE, DIFFIO_RX_T18P
EG P38	E9	8, E9, IO, , DIFFIO_RX_T18N
EG P42	D7	8, D7, IO, VREFB8N0, .
boot_sel	H10	8, H10, IO, , BOOT_SEL, .
GPIO 04	A2	8, A2, IO, , DIFFIO_RX_T19P
GPIO 06	A3	8, A3, IO, , DIFFIO_RX_T19N
GPIO 05	B3	8, B3, IO, , DIFFIO_RX_T20P
GPIO 09	B5	8, B5, IO, , DIFFIO_RX_T21P
GPIO 07	B4	8, B4, IO, , DIFFIO_RX_T20N
EG P49	C4	8, C4, IO, , DIFFIO_RX_T21N
EG P39	E8	8, E8, IO, , DIFFIO_RX_T22P
EG P48	C5	8, C5, IO, , DIFFIO_RX_T23P
CRC_error	F7	8, F7, IO, , CRC_ERROR, DIFFIO_RX_T22N
EG P47	D5	8, D5, IO, , DIFFIO_RX_T23N
nstatus	G9	8, G9, IO, , NSTATUS, DIFFIO_RX_T24P
GPIO_01	B2	8, B2, IO, , DIFFIO_RX_T25P
conf_done	F8	8, F8, IO, , CONF_DONE, DIFFIO_RX_T24N
GPIO 02	B1	8, B1, IO, , DIFFIO_RX_T25N
EG P45	D6	8, D6, IO, , DIFFIO_RX_T26P
GPIO 03	C3	8, C3, IO, , DIFFIO_RX_T27P
EG P41	E6	8, E6, IO, , DIFFIO_RX_T26N
RESET_EXP#	C2	8, C2, IO, , DIFFIO_RX_T27N
nconfig	H9	8, H9, INPUT_ONLY, , NCONFIG, .

10M08DAF484_V2
U2C

EG P57	N4	2, N4, IO, CLK0N, , DIFFIO_RX_L18N
EG P60	P4	2, P4, IO, , DIFFIO_RX_L19N
EG P56	N5	2, N5, IO, CLK0P, , DIFFIO_RX_L18P
EG P59	P5	2, P5, IO, , DIFFIO_RX_L19P
EG P53	M8	2, M8, IO, CLK1N, , DIFFIO_RX_L20N
EG P58	N3	2, N3, IO, , DIFFIO_RX_L21N
EG P52	M9	2, M9, IO, CLK1P, , DIFFIO_RX_L20P
EG P13	N2	2, N2, IO, , DIFFIO_RX_L21P
EG P14	P3	2, P3, IO, DPCLK0, , DIFFIO_RX_L22N
USER_LED1	M2	2, M2, IO, VREFB2N0, .
EG P16	R3	2, R3, IO, DPCLK1, , DIFFIO_RX_L22P
PB1	M1	2, M1, IO, .
EG P18	R4	2, R4, IO, , DIFFIO_RX_L23N
USER_LED4	T1	2, T1, IO, , DIFFIO_RX_L24N
EXP_PRESENT	R5	2, R5, IO, , DIFFIO_RX_L23P
EG P17	T2	2, T2, IO, , DIFFIO_RX_L24P
EG P55	N8	2, N8, IO, , DIFFIO_RX_L25N
EG P15	P1	2, P1, IO, , DIFFIO_RX_L26N
EG P54	N9	2, N9, IO, , DIFFIO_RX_L25P
USER_LED2	N1	2, N1, IO, , DIFFIO_RX_L26P
EG P19	T5	2, T5, IO, PLL_L_CLKOUTN, , DIFFIO_RX_L27N
PB2	R1	2, R1, IO, , DIFFIO_RX_L28N
USER_LED6	T6	2, T6, IO, PLL_L_CLKOUTP, , DIFFIO_RX_L27P
USER_LED3	R2	2, R2, IO, , DIFFIO_RX_L28P

10M08DAF484_V2

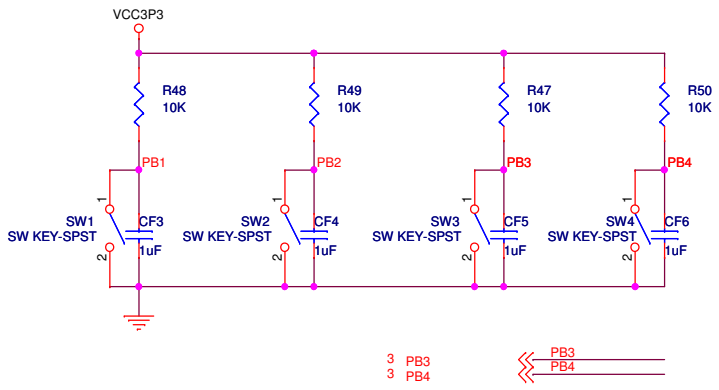
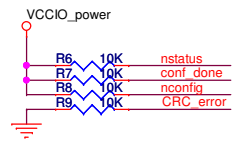
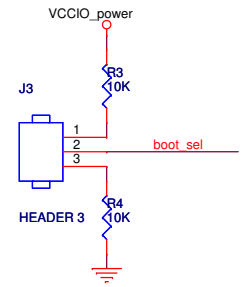
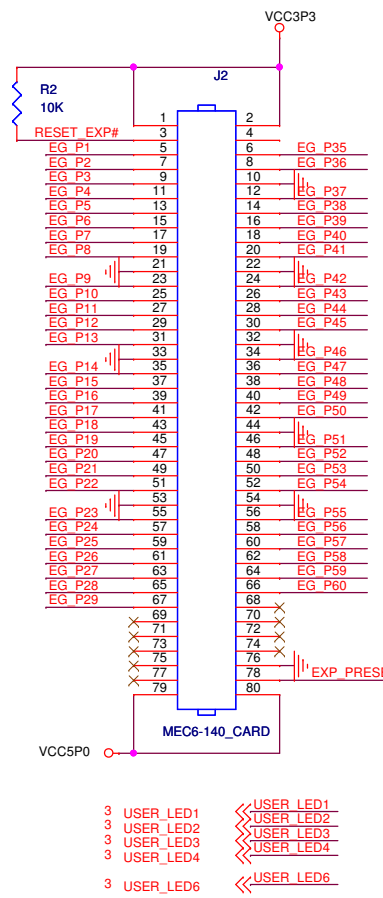

Title		
03 80-pin Edge connector		
Size	Document Number	Rev
B	<Doc>	A4
Date:	Thursday, October 09, 2014	Sheet 3 of 8

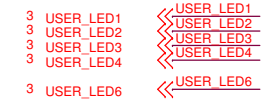
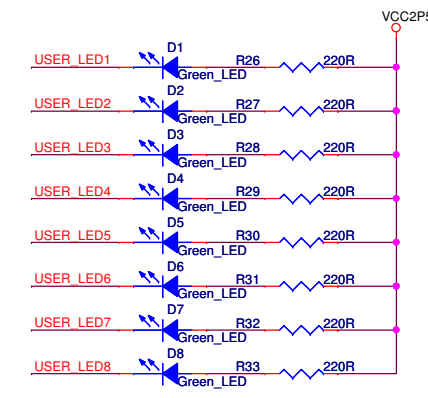
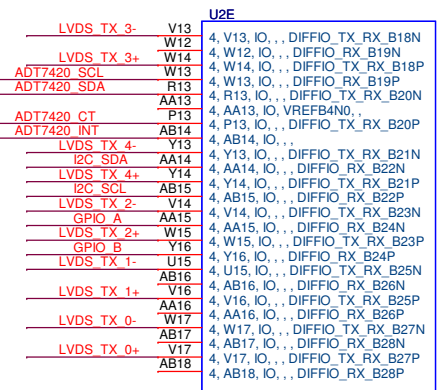
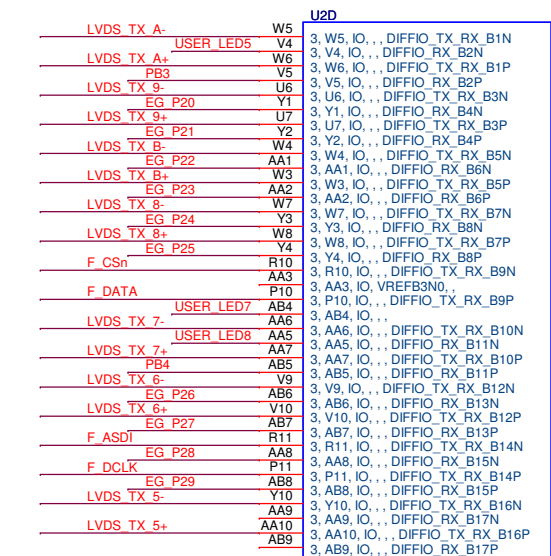
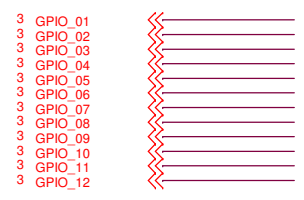
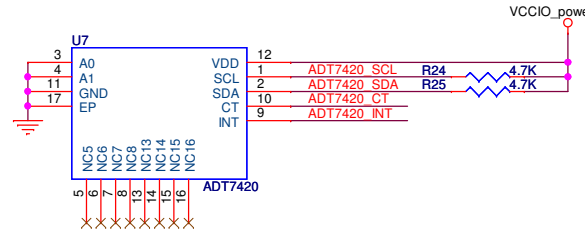
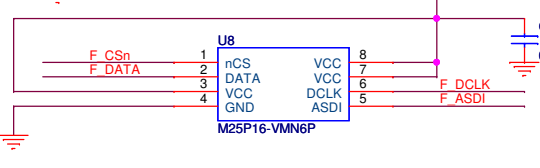
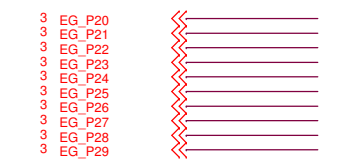
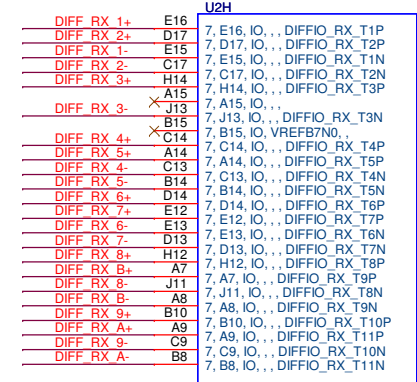
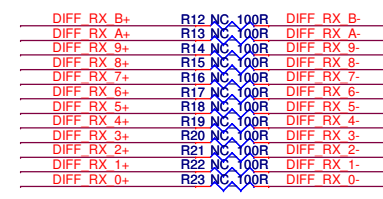
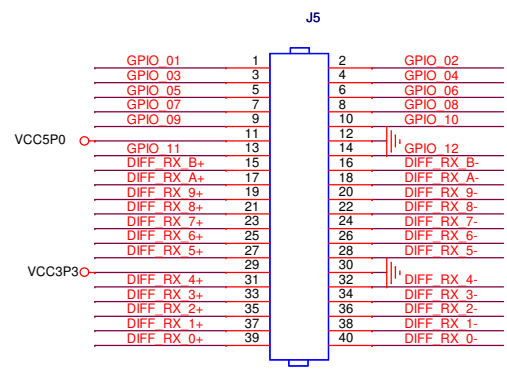
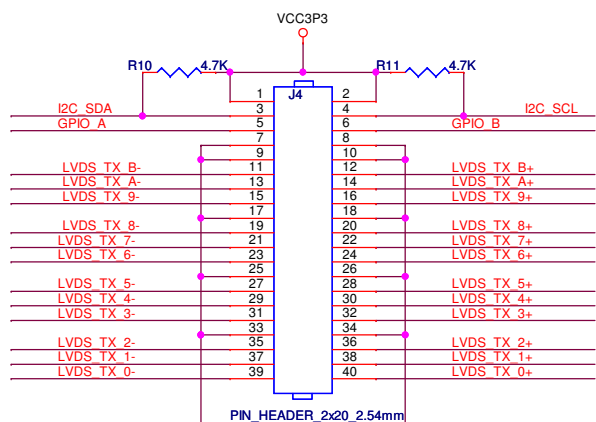

Title		
04 2X20 PIN HEADER		
Size	Document Number	Rev
B	<Doc>	A4
Date:	Thursday, October 09, 2014	Sheet 4 of 8

10M08DAF484_V2

10M08DAF484_V2



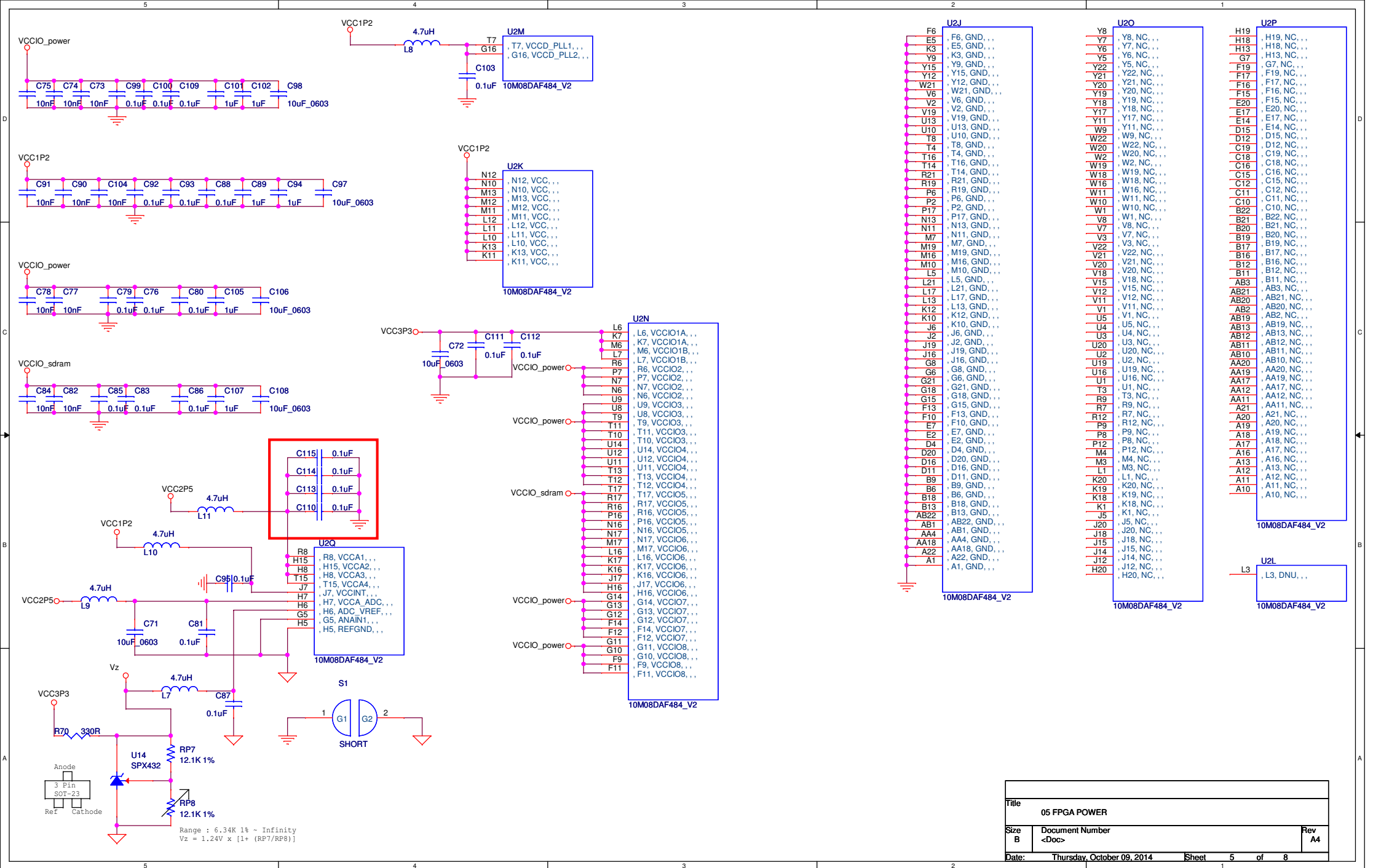

Title		
05 FPGA POWER		
Size	Document Number	Rev
B	<Doc>	A4
Date:	Thursday, October 09, 2014	Sheet 5 of 8

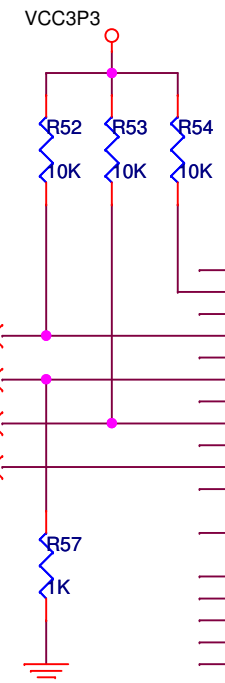
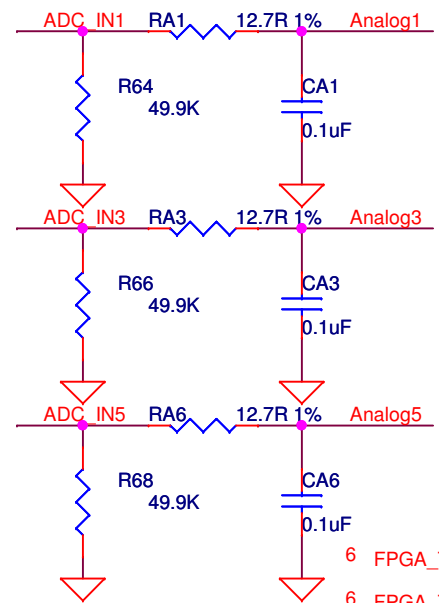
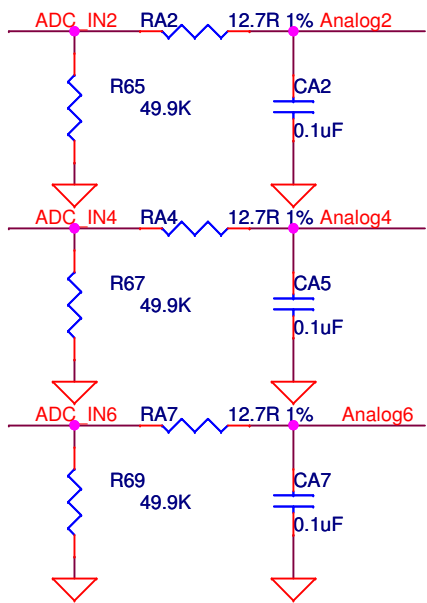
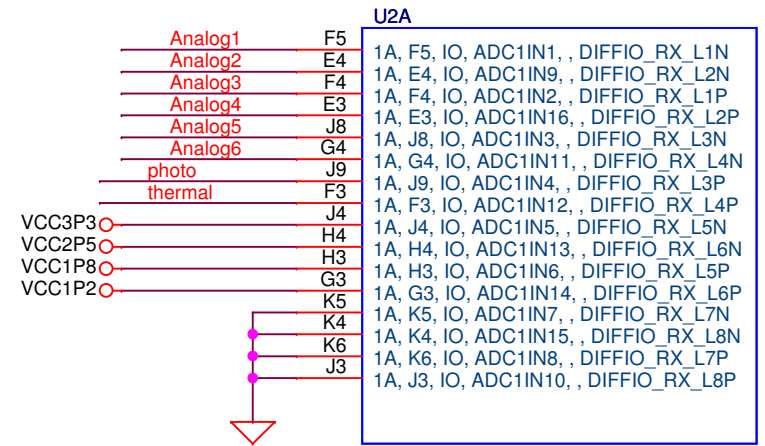
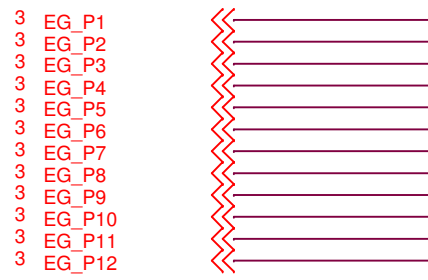
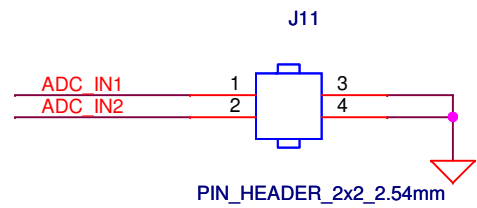

Place RC FILTERS close to MAX10/IO

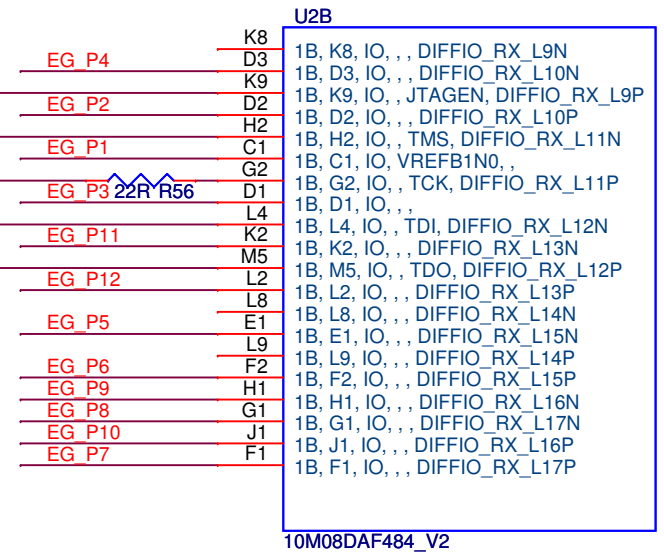
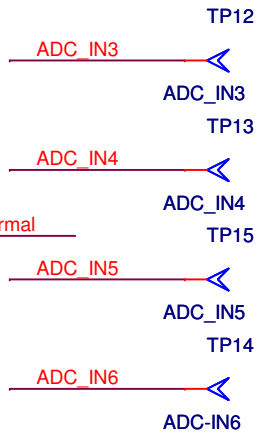
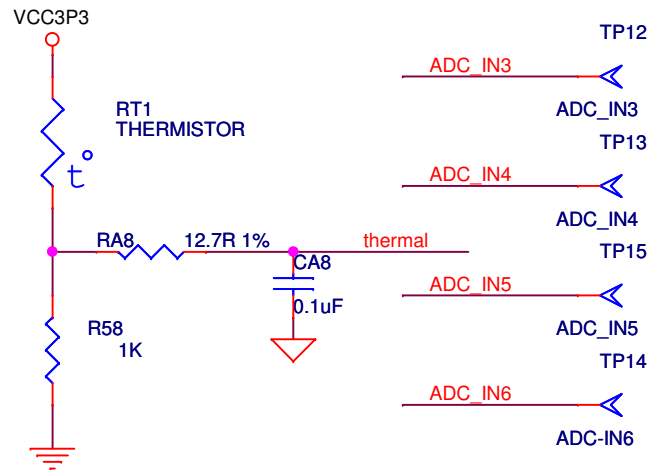
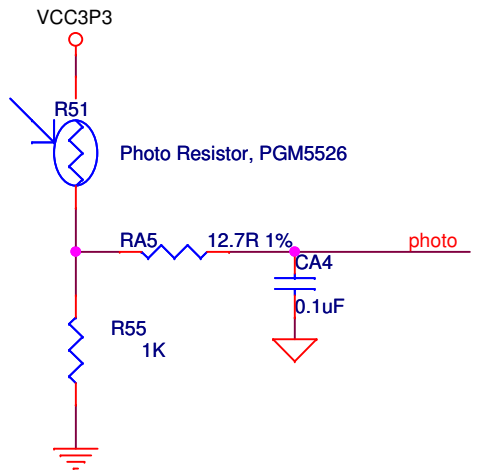

Title		
07 ADC		
Size	Document Number	Rev
A	<Doc>	A4
Date:	Thursday, October 09, 2014	Sheet 7 of 8

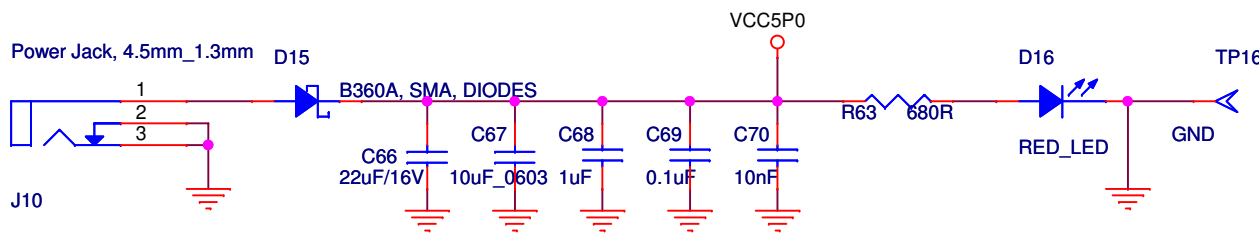
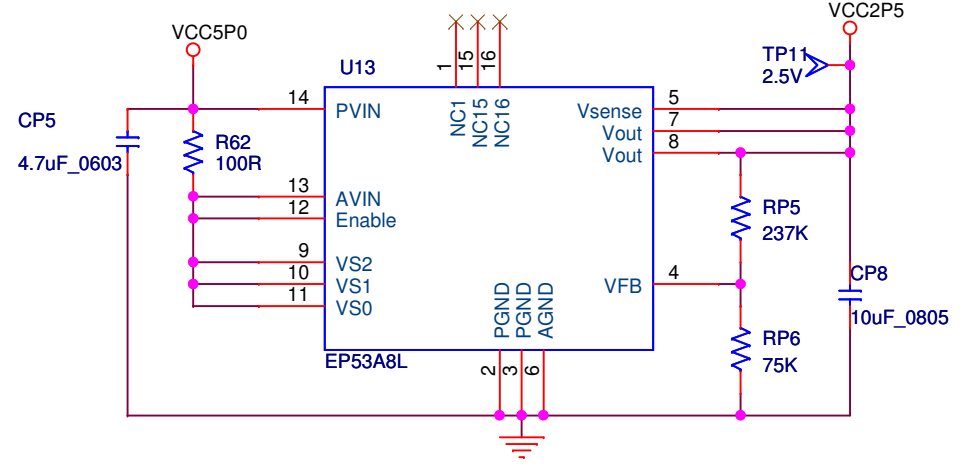
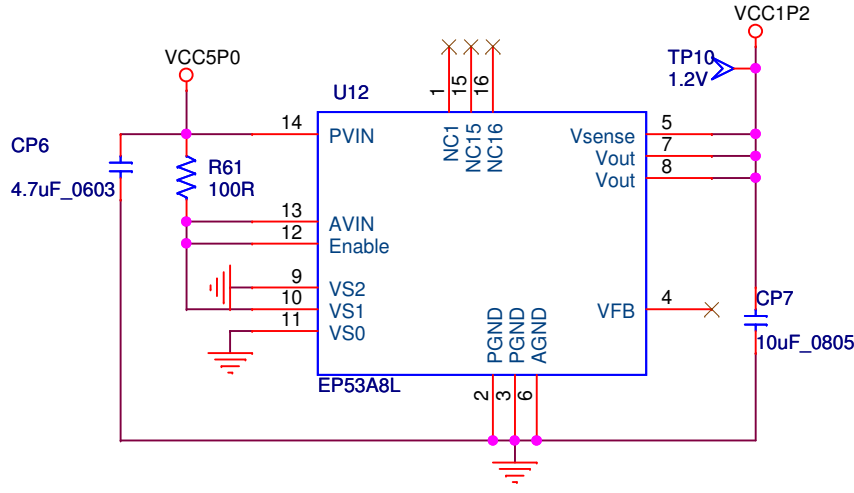
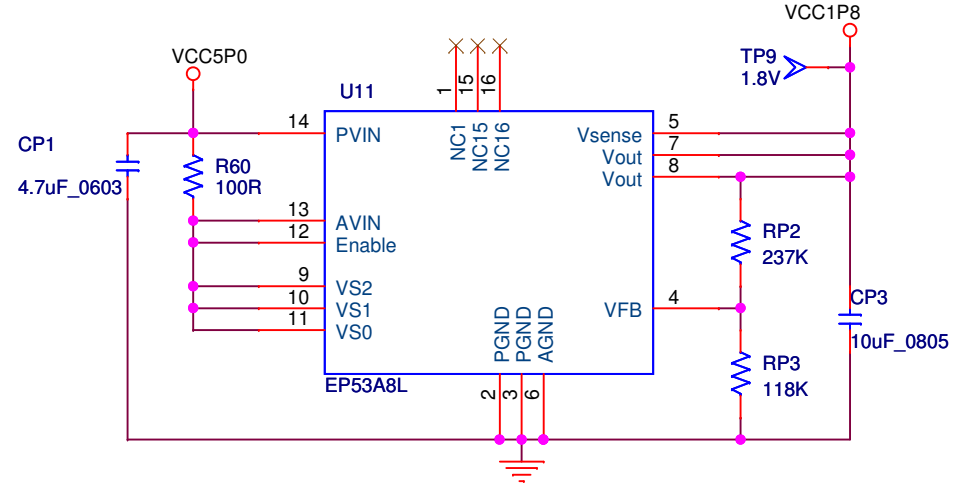
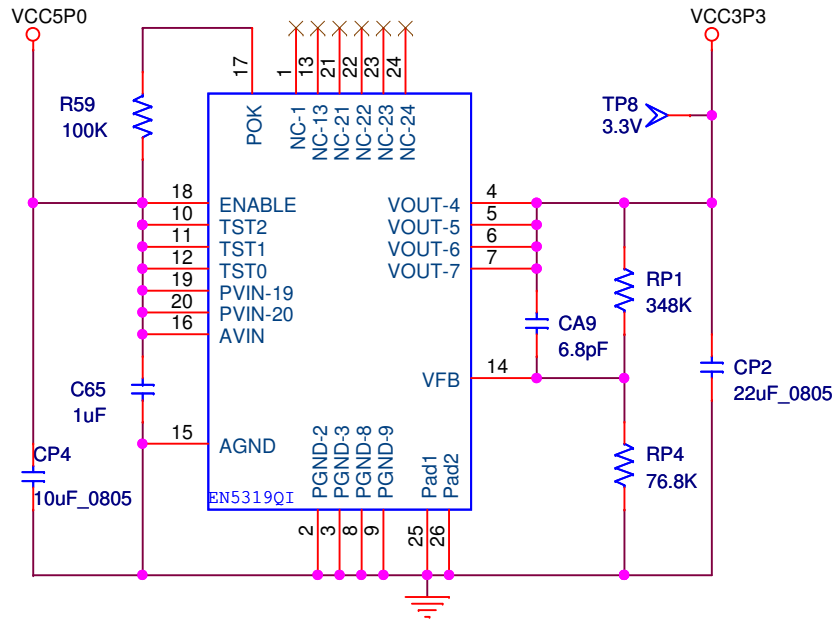

Title		
08 ENPIRION		
Size	Document Number	Rev
A	<Doc>	A4
Date:	Thursday, October 09, 2014	Sheet 8 of 8