

# Intel<sup>®</sup> Server System SR2520SA User's Guide

**A Guide for Technically Qualified Assemblers of Intel<sup>®</sup> Identified Subassemblies/  
Products**

Intel Order Number D69842-003

## **Disclaimer**

Information in this document is provided in connection with Intel® products. No license, express or implied, by estoppel or otherwise, to any intellectual property rights is granted by this document. Except as provided in Intel's Terms and Conditions of Sale for such products, Intel assumes no liability whatsoever, and Intel disclaims any express or implied warranty, relating to sale and/or use of Intel products including liability or warranties relating to fitness for a particular purpose, merchantability, or infringement of any patent, copyright or other intellectual property right. Intel products are not designed, intended or authorized for use in any medical, life saving, or life sustaining applications or for any other application in which the failure of the Intel product could create a situation where personal injury or death may occur. Intel may make changes to specifications and product descriptions at any time, without notice.

Intel server boards contain a number of high-density VLSI and power delivery components that need adequate airflow for cooling. Intel's own chassis are designed and tested to meet the intended thermal requirements of these components when the fully integrated system is used together. It is the responsibility of the system integrator that chooses not to use Intel developed server building blocks to consult vendor datasheets and operating parameters to determine the amount of airflow required for their specific application and environmental conditions. Intel Corporation can not be held responsible if components fail or the server board does not operate correctly when used outside any of their published operating or non-operating limits.

Intel, Intel Pentium, and Intel Xeon are trademarks or registered trademarks of Intel Corporation or its subsidiaries in the United States and other countries.

\* Other names and brands may be claimed as the property of others.

Copyright © 2010, Intel Corporation. All Rights Reserved



§

# Preface

---

## About this Manual

Thank you for purchasing and using the Intel® Server System SR2520SA.

This manual is written for system technicians who are responsible for troubleshooting, upgrading, and repairing this server system. This document provides reference information, feature information, and step by step instructions on how to add and replace components on the server system. For the latest version of this manual, see <http://support.intel.com/support/motherboards/server/s5000vsa/>.

## Manual Organization

Chapter 1 provides a list of reference resources. In this chapter you will find a list of technical documents that give additional details on the Intel® Server System SR2520SA, and the location where they can be found.

Chapter 2 provides a brief overview of the server system. In this chapter, you will find a list of the server system features, illustrations of the product, and product diagrams to help you identify components and their locations.

Chapter 3 provides instructions on using the utilities that are shipped with the board or that may be required to update the system. This includes how to navigate through the BIOS Setup screens, how to perform a BIOS update, and how to reset the password or CMOS. Information about the specific BIOS settings and screens is available in the Intel® 5000 Series Chipsets Server Board Family Datasheet. See “[Server System References](#)” for a link to the Intel® 5000 Series Chipsets Server Board Family Datasheet.

Chapter 4 provides instructions on adding and replacing components. Use this chapter for step-by-step instructions and diagrams for installing or replacing components such as the fans, power supply, drives, and other components.

At the back of this manual, you will find technical specifications, regulatory information, "getting help" information, and the warranty.

## Product Contents

The Intel® Server System SR2520SA ships with the Intel® Server Board S5000VSA. For further information, see the Intel® Server Board S5000VSA User's Guide.

There are three versions of this server system: the Intel® Server Systems SR2520SAX/SR2520SAXS and SR2520SAXR/SR2520SAXSR (SAS/SATA versions) and the Intel® Server System SR2520SAF/SR2520SAFR (SATA only version). The contents of each server system are listed below.

## Intel® Server System SR2520SAX/SR2520SAXR Contents

Your Intel® Server System SR2520SAX/SR2520SAXR ships with the following items:

- Intel® Server Board S5000VSA (SATA SKU), installed in the server system
- One 600 W hot-swap power supply module, installed in the server system
- Hot-swap power cage, installed in the server system
- Two 80mm system fans, installed in the server system
- One 60mm system fan, installed in the server system
- Passive backplane, installed in the server system
- CPU air duct, installed in the server system
- Four hot-swap drive carriers, installed in the server system
- Standard control panel, installed in the server system
- Slimline USB floppy drive, installed in the server system
- Six SATA cables, installed in the server system
- SPGIO cable, installed in the server system
- Front panel cable, installed in the server system
- USB Y cable for floppy drive and front panel cable, installed in the server system
- I/O shield, installed in the server system
- Quick Reference Label, installed inside the server system top cover
- Front panel sub-bezel assembly, installed in the server system
- CD-ROM cable, in the server system product box
- Attention document, in the server system product box
- Quick Start User's Guide, in the server system product box
- Rack handles, in the server system product box
- Rails, in the server system product box
- Intel Software CD combo kit, in the server system product box
- 3rd party software CD, in the server system product box

## Intel® Server System SR2520SAXS/SR2520SAXSR Contents

Your Intel® Server System SR2520SAXS/SR2520SAXSR ships with the following items:

- Intel® Server Board S5000VSA (SAS SKU), installed in the server system
- One 600 W hot-swap power supply module, installed in the server system
- Hot-swap power cage, installed in the server system
- Two 80mm system fans, installed in the server system
- One 60mm system fan, installed in the server system
- Active backplane, installed in the server system
- CPU air duct, installed in the server system
- Four hot-swap drive carriers, installed in the server system
- Standard control panel, installed in the server system
- Slimline USB floppy drive, installed in the server system
- Two SAS cables, installed in the server system
- I2C cable, installed in the server system
- Front panel cable, installed in the server system
- USB Y cable for floppy drive and front panel cable, installed in the server system
- I/O shield, installed in the server system
- Quick Reference Label, installed inside the server system top cover
- Front panel sub-bezel assembly, installed in the server system
- CD-ROM cable, in the server system product box
- Attention document, in the server system product box
- Quick Start User's Guide, in the server system product box
- Rack handles, in the server system product box
- Rails, in the server system product box
- Intel Software CD combo kit, in the server system product box
- 3rd party software CD, in the server system product box

## Intel® Server System SR2520SAF/SR2520SAFR Contents

Your Intel® Server System SR2520SAF/SR2520SAFR ships with the following items:

- Intel® Server Board S5000VSA (4 DIMM SKU), installed in the server system
- One 600 W fixed power supply module, installed in the server system
- Two 80mm system fans, installed in the server system
- One 60mm system fan, installed in the server system
- CPU air duct, installed in the server system
- Standard control panel, installed in the server system
- Slimline USB floppy drive, installed in the server system
- Front panel cable, installed in the server system
- USB Y cable for floppy drive and front panel cable, installed in the server system
- I/O shield, installed in the server system
- Quick Reference Label, installed inside the server system top cover
- Front panel sub-bezel assembly, installed in the server system
- CD-ROM cable, in the server system product box
- Six SATA cables, in the server system product box
- Bagged screws, in the server system product box
- Attention document, in the server system product box
- Quick Start User's Guide, in the server system product box
- Rack handles, in the server system product box
- Rails, in the server system product box
- Intel Software CD combo kit, in the server system product box
- 3rd party software CD, in the server system product box



# Safety Information

---

## Important Safety Instructions

Read all caution and safety statements in this document before performing any of the instructions. See also Intel Server Boards and Server Chassis Safety Information on the *Intel® Server Deployment Toolkit 2.0 CD* and/or at <http://support.intel.com/support/motherboards/server/sb/cs-010770.htm>.

## Wichtige Sicherheitshinweise

Lesen Sie zunächst sämtliche Warnung und Sicherheitshinweise in diesem Dokument, bevor Sie eine der Anweisungen ausführen. Beachten Sie hierzu auch die Sicherheitshinweise zu Intel-Serverplatinen und Servergehäusen auf der *Intel® Server Deployment Toolkit 2.0 CD* oder unter <http://support.intel.com/support/motherboards/server/sb/cs-010770.htm>.

## Consignes de sécurité

Lisez attention toutes les consignes de sécurité et les mises en garde indiquées dans ce document avant de suivre toute instruction. Consultez Intel Server Boards and Server Chassis Safety Information sur le *Intel® Server Deployment Toolkit 2.0 CD* ou bien rendez-vous sur le site <http://support.intel.com/support/motherboards/server/sb/cs-010770.htm>.

## Instrucciones de seguridad importantes

Lea todas las declaraciones de seguridad y precaución de este documento antes de realizar cualquiera de las instrucciones. Vea Intel Server Boards and Server Chassis Safety Information en el *Intel® Server Deployment Toolkit 2.0 CD* y/o en <http://support.intel.com/support/motherboards/server/sb/cs-010770.htm>.

## 重要安全指导

在执行任何指令之前，请阅读本文档中的所有注意事项及安全声明。和/或 <http://support.intel.com/support/motherboards/server/sb/CS-010770.htm> 上的 *Intel Server Boards and Server Chassis Safety Information* (《Intel 服务器主板与服务器机箱安全信息》)。

# Warnings

**Heed safety instructions:** Before working with your server product, whether you are using this guide or any other resource as a reference, pay close attention to the safety instructions. You must adhere to the assembly instructions in this guide to ensure and maintain compliance with existing product certifications and approvals. Use only the described, regulated components specified in this guide. Use of other products / components will void the UL listing and other regulatory approvals of the product and will most likely result in noncompliance with product regulations in the region(s) in which the product is sold.

**System power on/off:** The power button DOES NOT turn off the system AC power. To remove power from system, you must unplug the AC power cord from the wall outlet. Make sure the AC power cord is unplugged before you open the chassis, add, or remove any components.

**Hazardous conditions, devices and cables:** Hazardous electrical conditions may be present on power, telephone, and communication cables. Turn off the server and disconnect the power cord, telecommunications systems, networks, and modems attached to the server before opening it. Otherwise, personal injury or equipment damage can result.

**Electrostatic discharge (ESD) and ESD protection:** ESD can damage disk drives, boards, and other parts. We recommend that you perform all procedures in this chapter only at an ESD workstation. If one is not available, provide some ESD protection by wearing an antistatic wrist strap attached to chassis ground any unpainted metal surface on your server when handling parts.

**ESD and handling boards:** Always handle boards carefully. They can be extremely sensitive to ESD. Hold boards only by their edges. After removing a board from its protective wrapper or from the server, place the board component side up on a grounded, static free surface. Use a conductive foam pad if available but not the board wrapper. Do not slide board over any surface.

**Installing or removing jumpers:** A jumper is a small plastic encased conductor that slips over two jumper pins. Some jumpers have a small tab on top that you can grip with your fingertips or with a pair of fine needle nosed pliers. If your jumpers do not have such a tab, take care when using needle nosed pliers to remove or install a jumper; grip the narrow sides of the jumper with the pliers, never the wide sides. Gripping the wide sides can damage the contacts inside the jumper, causing intermittent problems with the function controlled by that jumper. Take care to grip with, but not squeeze, the pliers or other tool you use to remove a jumper, or you may bend or break the pins on the board.



# Table of Contents

---

<b>Preface</b> .....	<b>v</b>
About this Manual .....	v
Manual Organization .....	v
Product Contents .....	v
Intel® Server System SR2520SAX Contents .....	vi
Intel® Server System SR2520SAXS Contents .....	vii
Intel® Server System SR2520SAF Contents .....	viii
<b>Safety Information</b> .....	<b>ix</b>
Important Safety Instructions .....	ix
Wichtige Sicherheitshinweise .....	ix
Consignes de sécurité .....	ix
Instrucciones de seguridad importantes .....	ix
<b>Chapter 1: Server System References</b> .....	<b>1</b>
<b>Chapter 2: Server System Features</b> .....	<b>3</b>
Chassis Component Identification .....	7
Internal Components .....	7
Configuration Jumpers .....	10
Hot-Swap Backplane .....	14
SATA .....	15
Control Panel .....	17
Bezels .....	18
Peripheral Devices .....	18
Hard Disk Drives .....	19
Rack-Mounted Systems .....	19
<b>Chapter 3: Hardware Installations and Upgrades</b> .....	<b>21</b>
Before You Begin .....	21
Tools and Supplies Needed .....	21
System References .....	21
Removing and Installing from a Rack .....	21
Fixed Bracket Rack Mount Removal .....	21
Fixed Bracket Rack Mount Installation .....	22
Basic Rail Rack Mount Removal .....	23
Basic Rail Rack Mount Installation .....	23
Removing and Installing the Front Bezel .....	24
Removing the Front Bezel .....	25
Installing the Front Bezel .....	26
Removing and Installing the System Cover .....	26

Removing the System Cover .....	26
Installing the System Cover .....	27
Removing and Installing the Processor Air Duct .....	28
Removing the Processor Air Duct .....	28
Installing the Processor Air Duct .....	30
Installing and Removing Memory .....	31
Installing DIMMs .....	31
Removing DIMMs .....	33
Installing the Processor .....	33
Installing the Heat Sink(s) .....	35
Removing a Processor .....	36
Installing and Removing a Hot-swap Hard Drive (SR2520SAX/SR2520SAXS and SR2520SAXR/SR2520SAXSR) .....	37
Installing a SAS or SATA Hot-swap Hard Disk Drive (SR2520SAX/SR2520SAXS and SR2520SAXR/SR2520SAXSR) .....	37
Removing a SAS or SATA Hot-swap Hard Disk Drive (SR2520SAX/SR2520SAXS and SR2520SAXR/SR2520SAXSR) .....	41
Installing and Removing a Fixed Hard Drive (SR2520SAF/SR2520SAFR) .....	41
Installing a Fixed Hard Disk Drive (SR2520SAF/SR2520SAFR) .....	41
Removing a Fixed Hard Disk Drive (SR2520SAF/SR2520SAFR) .....	43
Installing or Removing the Optical Drive .....	44
Installing the Optical Drive .....	44
Removing the Optical Drive .....	46
Installing and Removing a PCI Add-in Card .....	48
Installing a PCI Add-in Card .....	48
Removing a PCI Add-in Card .....	49
Installing and Removing the Server Board .....	50
Installing the Server Board .....	50
Removing the Server Board .....	51
Replacing the Backup Battery .....	52
Replacing the Redundant Power Supply (SR2520SAX/SR2520SAXS and SR2520SAXR/ SR2520SAXSR) .....	54
Replacing the Fixed Power Supply (SR2520SAF/SR2520SAFR) .....	55
Replacing the Front Panel Board .....	57
Replacing a System Fan .....	60
Installing and Removing the Rack Handles .....	62
Installing the Rack Handles .....	62
Removing the Rack Handles .....	63
<b>Chapter 4: Server Utilities .....</b>	<b>65</b>
Using the BIOS Setup Utility .....	65
Starting Setup .....	65
If You Cannot Access Setup .....	65
Setup Menus .....	65
Upgrading the BIOS .....	67

Preparing for the Upgrade .....	67
Upgrading the BIOS .....	68
Clearing the Password .....	68
Clearing the CMOS .....	69
<b>Appendix A: Technical Reference .....</b>	<b>71</b>
Cable Routing (SR2520SAX/SR2520SAXS and SR2520SAXR/SR2520SAXSR) .....	71
Cable Routing (SR2520SAF/SR2520SAFR) .....	72
600W Single Power Supply Input Voltages .....	73
600W Single Power Supply Output Voltages .....	73
System Environmental Specifications .....	74
<b>Appendix B: LED Decoder (SR2520SAX /SR2520SAXS and SR2520SAXR/ SR2520SAXSR Only) .....</b>	<b>75</b>
<b>Appendix C: Getting Help .....</b>	<b>81</b>
World Wide Web .....	81
Telephone .....	81
<b>Appendix D: Regulatory and Compliance Information .....</b>	<b>85</b>
Product Regulatory Compliance .....	85
Product Safety Compliance .....	85
Product EMC Compliance - Class A Compliance .....	86
Certifications / Registrations / Declarations .....	87
Product Regulatory Compliance Markings .....	87
Electromagnetic Compatibility Notices .....	89
FCC Verification Statement (USA) .....	89
Industry Canada (ICES-003) .....	90
Europe (CE Declaration of Conformity) .....	90
VCCI (Japan) .....	90
BSMI (Taiwan) .....	90
Korean Compliance (RRL) .....	91
Regulated Specified Components .....	91
Restriction of Hazardous Substances (RoHS) Compliance .....	92
End-of-Life / Product Recycling .....	92
<b>Appendix E: Warranty .....</b>	<b>93</b>
Limited Warranty for Intel® Chassis Subassembly Products .....	93
<b>Appendix F: Troubleshooting .....</b>	<b>97</b>
Resetting the System .....	97
Problems following Initial System Installation .....	98
First Steps Checklist .....	98
Hardware Diagnostic Testing .....	99
Verifying Proper Operation of Key System Lights .....	99
Confirming Loading of the Operating System .....	99

Specific Problems and Corrective Actions .....	99
Power Light Does Not Light .....	100
No Characters Appear on Screen .....	100
Characters Are Distorted or Incorrect .....	101
System Cooling Fans Do Not Rotate Properly .....	101
Drive Activity Light Does Not Light .....	102
CD-ROM Drive or DVD-ROM Drive Activity Light Does Not Light .....	102
Cannot Connect to a Server .....	102
Problems with Network .....	103
System Boots when Installing PCI Card .....	104
Problems with Newly Installed Application Software .....	104
Problems with Application Software that Ran Correctly Earlier .....	104
Devices are not Recognized under Device Manager (Microsoft* Windows* Operating System) .....	105
Hard Drive(s) are not Recognized .....	105
Bootable CD-ROM Disk Is Not Detected .....	105
LED Information .....	106
BIOS POST Beep Codes .....	106
<b>Appendix G: Installation/Assembly Safety Instructions .....</b>	<b>107</b>
English .....	107
Deutsch .....	109
Français .....	111
Español .....	113
Italiano .....	115
<b>Appendix H: Safety Information .....</b>	<b>119</b>
English .....	119
Server Safety Information .....	119
Safety Warnings and Cautions .....	119
Intended Application Uses .....	120
Site Selection .....	120
Equipment Handling Practices .....	120
Power and Electrical Warnings .....	121
System Access Warnings .....	122
Rack Mount Warnings .....	122
Electrostatic Discharge (ESD) .....	123
Other Hazards .....	123
Deutsch .....	124
Sicherheitshinweise für den Server .....	124
Sicherheitshinweise und Vorsichtsmaßnahmen .....	124
Zielbenutzer der Anwendung .....	125
Standortauswahl .....	125
Handhabung von Geräten .....	125
Warnungen zu Netzspannung und Elektrizität .....	126



Warnhinweise für den Systemzugang .....	127
Warnhinweise für Racks .....	127
Elektrostatische Entladungen (ESD) .....	128
Andere Gefahren .....	128
Français .....	129
Consignes de securite sur le serveur .....	129
Sécurité: avertissements et mises en garde .....	129
Domaines d'utilisation prévus .....	130
Sélection d'un emplacement .....	130
Pratiques de manipulation de l'équipement .....	131
Alimentation et avertissements en matière d'électricité .....	131
Avertissements sur le cordon d'alimentation .....	132
Avertissements sur l'accès au système .....	132
Avertissements sur le montage en rack .....	133
Décharges électrostatiques (ESD) .....	134
Autres risques .....	134
Périphériques laser .....	135
Español .....	135
Información de seguridad del servidor .....	135
Advertencias y precauciones sobre seguridad .....	135
Aplicaciones y usos previstos .....	136
Selección de la ubicación .....	136
Manipulación del equipo .....	137
Advertencias de alimentación y eléctricas .....	137
Advertencias sobre el cable de alimentación .....	137
Advertencias el acceso al sistema .....	138
Advertencias sobre el montaje en bastidor .....	139
Descarga electrostática (ESD) .....	139
Otros riesgos .....	140



# List of Figures

---

Figure 1. Intel® Server System SR2520SA .....	3
Figure 2. ChassisComponents (SR2520SAX/SR2520SAXS and SR2520SAXR/ SR2520SAXSR) .....	7
Figure 3. ChassisComponents (SR2520SAF/SR2520SAFR) .....	8
Figure 4. Server Board Connector and Component Locations .....	9
Figure 5. BIOS Select Jumper.....	10
Figure 6. Recovery Jumpers .....	11
Figure 7. Light Guided Diagnostic LEDs (SR2520SAX/SR2520SAXS and SR2520SAXR/ SR2520SAXSR) .....	12
Figure 8. Intel® Server System SR2520SAF/SR2520SAFR Back Panel Connectors .....	13
Figure 9. Intel® Server System SR2520SAX/SR2520SAXS and SR2520SAXR/SR2520SAXSR Back Panel Connectors.....	13
Figure 10. Hot-Swap Backplane.....	14
Figure 11. Standard Control Panel.....	17
Figure 12. Optional Peripherals (SR2520SAX/SR2520SAXS and SR2520SAXR/ SR2520SAXSR) .....	18
Figure 13. Optional Peripherals (SR2520SAF/SR2520SAFR).....	18
Figure 14. Front View with Bezel.....	24
Figure 15. Removing the Front Bezel.....	25
Figure 16. Installing the Front Bezel.....	26
Figure 17. Removing the Server System Cover.....	27
Figure 18. Installing the Server System Cover.....	28
Figure 19. Removing the Processor Air Duct.....	29
Figure 20. Installing the Processor Air Duct.....	30
Figure 21. Installing the Memory.....	32
Figure 22. Lifting the Processor Socket Handle .....	34
Figure 23. Installing the Processor.....	34
Figure 24. Removing the Socket Cover .....	35
Figure 25. Installing the Heat Sink (2U Passive Heat Sink Shown) .....	36
Figure 26. Removing Hot-swap Disk Carrier from the Server System (SR2520SAX/ SR2520SAXS and SR2520SAXR/SR2520SAXSR) .....	38
Figure 27. Removing Retention Device from Drive Carrier (SR2520SAX/SR2520SAXS and SR2520SAXR/SR2520SAXSR) .....	39
Figure 28. Install Drive Assembly into the Server System (SR2520SAX/SR2520SAXS and SR2520SAXR/SR2520SAXSR) .....	40
Figure 29. Installing Fixed Hard Drive(s) into the Server System (SR2520SAF/SR2520SAFR) . 42	
Figure 30. Removing Fixed Hard Drive(s) from the Server System (SR2520SAF/SR2520SAFR) 43	
Figure 31. Removing Drive Bracket from the Server System.....	44
Figure 32. Installing Optical Drive into the Drive Bracket.....	45
Figure 33. Removing Optical Drive Knockout .....	45

Figure 34. Installing Optical Drive and Drive Bracket into Server System .....	46
Figure 35. Removing Drive Bracket and Optical Drive from the Server System.....	47
Figure 36. Removing Optical Drive from Drive Bracket .....	47
Figure 37. Installing an Add-In Card .....	48
Figure 38. Removing an Add-In Card .....	49
Figure 39. Installing the Server Board .....	50
Figure 40. Removing the Server Board .....	51
Figure 41. Replacing the Backup Battery .....	53
Figure 42. Removing Power Supply Module from the Server System (SR2520SAX/ SR2520SAXS and SR2520SAXR/SR2520SAXSR) .....	54
Figure 43. Installing Power Supply Module into the Server System (SR2520SAX/SR2520SAXS and SR2520SAXR/SR2520SAXSR).....	55
Figure 44. Removing Power Supply Module from the Server System (SR2520SAF/ SR2520SAFR) .....	56
Figure 45. Installing Power Supply Module into the Server System (SR2520SAF/SR2520SAFR) 57	57
Figure 46. Removing the Front Panel Board .....	58
Figure 47. Removing the Light Pipes from the Front Panel Board .....	58
Figure 48. Installing Front Panel Board into the Server System .....	59
Figure 49. Installing Light Pipes onto the Front Panel Board.....	59
Figure 50. Removing the Fan Module.....	60
Figure 51. Removing a Fan from the Fan Module .....	61
Figure 52. Installing a Fan into the Fan Module.....	61
Figure 53. Installing the Fan Module.....	62
Figure 54. Installing the Rack Handle .....	63
Figure 55. Removing the Rack Handle .....	64
Figure 56. Clear Password Jumper .....	68
Figure 57. Clear CMOS Jumper .....	69
Figure 58. Cable Routing (SR2520SAX/SR2520SAXS and SR2520SAXR/SR2520SAXSR)	71
Figure 59. Cable Routing (SR2520SAF/SR2520SAFR) .....	72

# List of Tables

---

Table 1. Server System References .....	1
Table 2. Intel® Server System SR2520SA Feature Summary .....	4
Table 3. NIC LED Descriptions .....	14
Table 4. Setup Menu Key Use .....	66
Table 5. Power Supply Output Capability .....	73
Table 6. System Environmental Specifications .....	74
Table 7. POST Progress Code LED Example .....	75
Table 8. Diagnostic LED POST Code Decoder .....	76
Table 9. Product Regulatory Compliance Markings .....	87
Table 10. Resetting the System .....	97
Table 11. LED Information .....	106
Table 12. POST Error Beep Codes .....	106



# 1 Server System References

If you need more information about this product or information about the accessories that can be used with this server chassis, use the following resources.

**Table 1. Server System References**

<b>For this information or software</b>	<b>Use this Document or Software</b>
For in-depth technical information about the server system, including sub-system overviews and mechanical drawings	<p><i>Intel® Server Chassis SR2520SA Technical Product Specification</i>            Found at:  <a href="http://support.intel.com/support/motherboards/server/s5000vsa/">http://support.intel.com/support/motherboards/server/s5000vsa/</a></p> <p><i>Intel® Server Board S5000VSA Technical Product Specification</i>            Found at:  <a href="http://support.intel.com/support/motherboards/server/s5000vsa/">http://support.intel.com/support/motherboards/server/s5000vsa/</a></p>
For basic BIOS settings and chipset information	<p><i>Intel® 5000 Series Chipsets Server Board Family Datasheet</i>            Found at:  <a href="http://support.intel.com/support/motherboards/server/s5000vsa/">http://support.intel.com/support/motherboards/server/s5000vsa/</a></p>
For in-depth BIOS information	<p><i>Intel® S5000 Server Board Family Server BIOS External Product Specification</i>            Found: available to order by contacting your Intel field representative; Intel reference number 19953</p>
For in-depth firmware information on the Baseboard Management Controller (BMC)	<p><i>ESB2 Baseboard Management Controller Core External Product Specification for the Intel® S5000 Server Board Family</i>            Found: available to order by contacting your Intel field representative; Intel reference number 19692.</p>
For in-depth information on Intel® I/O Acceleration Technology	<p><i>Intel® I/O Acceleration Technology Improves Intel Server Platform Network Performance, Reliability, and Efficiency</i> whitepaper            Found: available from your Intel field representative</p>
If you just received this product and need to install it	<p><i>Intel® Integrated Server System SR2520SA Quick Start User's Guide</i>            Found: in the product box</p>
For virtual system tours and interactive repair information	<p>A link to the SMaRT Tool is available under "Other Resources" at the right side of the screen at  <a href="http://support.intel.com/support/motherboards/server/s5000vsa/">http://support.intel.com/support/motherboards/server/s5000vsa/</a></p>
Accessories or other Intel server products	<p>Spares and Configuration Guide            Found: available from your Intel field representative or on the Server Configurator Tool at <a href="http://indigo.intel.com/serverconfiguratortool/default.aspx">http://indigo.intel.com/serverconfiguratortool/default.aspx</a></p>

**Table 1. Server System References**

<b>For this information or software</b>	<b>Use this Document or Software</b>
Hardware (peripheral boards, adapter cards) and operating systems that have been tested with this product	Tested Hardware Operating Systems List Found at: <a href="http://support.intel.com/support/motherboards/server/s5000vsa/">http://support.intel.com/support/motherboards/server/s5000vsa/</a>
To make sure your system falls within the allowed power budget	Power Budget Tool Found at: <a href="http://support.intel.com/support/motherboards/server/s5000vsa/">http://support.intel.com/support/motherboards/server/s5000vsa/</a>
For software to manage your Intel® server	Intel® System Management Software Found at: <a href="http://support.intel.com/support/motherboards/server/sysmgmt/index.htm">http://support.intel.com/support/motherboards/server/sysmgmt/index.htm</a>
For diagnostics test software	Diagnostics Found at: <a href="http://support.intel.com/support/motherboards/server/s5000vsa/">http://support.intel.com/support/motherboards/server/s5000vsa/</a>



## 2 Server System Features

---

This chapter briefly describes the main features of the server system. This chapter provides illustrations of the product, a list of the server system features, and diagrams showing the location of important components and connections on the server system.

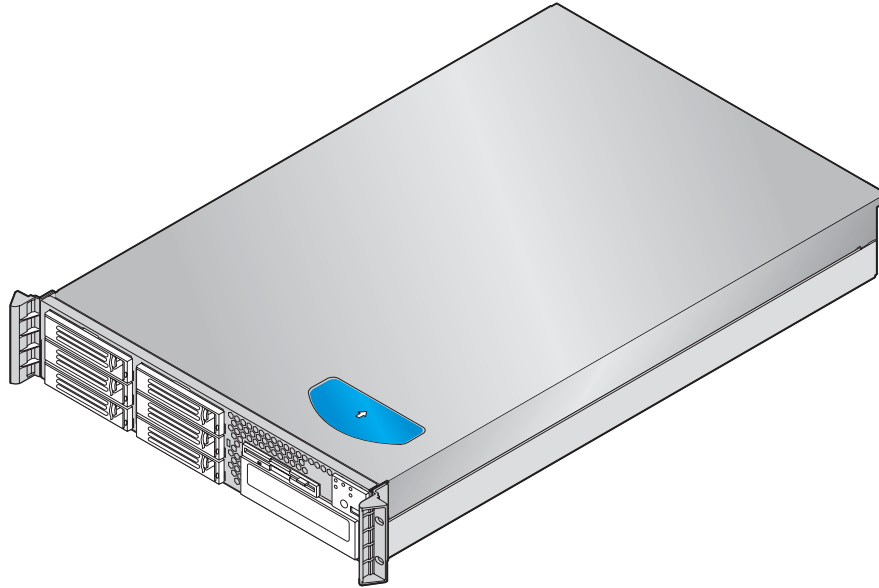

AF001439

**Figure 1. Intel® Server System SR2520SA**

Table 2 summarizes the features of the server system.

**Table 2. Intel® Server System SR2520SA Feature Summary**

Feature	Description
Dimensions	<ul style="list-style-type: none"> <li>• 3.44 inches (87.30 mm) high</li> <li>• 16.930 inches (430 mm) wide</li> <li>• 25.50 inches (647.7 mm) deep</li> <li>• 40 pounds (18.14 kg) - max chassis weight</li> </ul>
Server Board	Intel® Server Board S5000VSA
Processor	<p>Support for up to two Dual-Core Intel® Xeon® processors 5000 or 5100 sequence with a 677-, 1066-, or 1333-MHz front side bus.</p> <p>Up to two Quad-Core Intel® Xeon® processors 5300 sequence with a 1066- or 1333-MHz front side bus.</p> <p>Up to two 45nm 2P Dual-Core Intel® Xeon® processors. Product codes SR2520SAFR, SR2520SAXR, and SR2520SAXSR only.</p> <p>Up to two 45nm next generation Quad-Core Intel® Xeon® processors. Product codes SR2520SAFR, SR2520SAXR, and SR2520SAXSR only.</p>
Memory	<ul style="list-style-type: none"> <li>• SR2520SAX/SR2520SAXS and SR2520SAXR/SR2520SAXSR: Eight DIMM sockets supporting stacked 533/667 MHz compliant FBDIMM memory (up to 16 GB of total system memory)</li> <li>• SR2520SAF/SR2520SAFR: Four DIMM sockets supporting stacked 533/667 MHz compliant FBDIMM memory (up to 8 GB of total system memory)</li> </ul>
Chipset	<p>Intel® 5000V chipset, consisting of:</p> <ul style="list-style-type: none"> <li>• Intel® 5000V Memory Controller Hub (MCH)</li> <li>• Intel® 6321ESB I/O Controller Hub</li> </ul>

**Table 2. Intel® Server System SR2520SA Feature Summary**

Feature	Description
Peripheral Interfaces	<p><b>External connections:</b></p> <ul style="list-style-type: none"> <li>• Stacked PS/2* ports for keyboard and mouse</li> <li>• DB9 Serial A port</li> <li>• Two RJ45 NIC connectors for 10/100/1000 Mb connections</li> <li>• Four USB 2.0 ports</li> </ul> <p><b>Internal connections:</b></p> <ul style="list-style-type: none"> <li>• One USB port header, which supports two USB 2.0 ports</li> <li>• One DH10 Serial B header</li> <li>• SR2520SAF/SR2520SAX and SR2520SAXR/SR2520SAXSR: Six Serial ATA connectors with embedded RAID 0/1/10 support for S5000VSASATA/S5000VSASATAR and S5000VSASCSI/S5000VSASCSIR SKUs. Optional RAID 5 support requires an AXXRAKSW5 RAID key.</li> <li>• SR2520SAXS/SR2520SAXSR: Four SAS and two SATA connectors with embedded RAID 0/1/10 support for S5000VSASAS SKU. Optional RAID 5 support requires an AXXRAKSW5 RAID key.</li> <li>• One ATA-133 connector</li> <li>• SSI-compliant 34-pin, high-density 100-pin, and alternate 50-pin control panel headers</li> </ul>
I/O Controll	National Semiconductor* PC87427 controller
Video	On-board ATI* ES1000 video controller with 16 MB DDR SDRAM
LAN	Intel® 82563EB dual port controller for 10/100/1000 Mbit/sec Ethernet LAN connectivity
Expansion Capabilities	<ul style="list-style-type: none"> <li>• One 32-bit/33MHz, 5V PCI connector</li> <li>• One full length 64-bit/133MHz PCI-X* connector</li> <li>• One 64-bit/100MHz PCI-X* connector</li> <li>• Two x4 PCI Express* connectors</li> </ul> <p><b>NOTE:</b> Only low-profile PCI cards are supported in the Intel® Server System SR2520SA</p>
Peripherals	<ul style="list-style-type: none"> <li>• Slimline bay for IDE optical drive</li> <li>• PCI riser card bracket</li> </ul>
Control Panel	<ul style="list-style-type: none"> <li>• Standard control panel</li> </ul>
LEDs and displays (dependent on option selected)	<p>With standard control panel:</p> <ul style="list-style-type: none"> <li>• NIC1 Activity</li> <li>• NIC2 Activity</li> <li>• Power / Sleep</li> <li>• System Status</li> <li>• System Identification</li> <li>• Hard Drive Activity</li> </ul>

**Table 2. Intel® Server System SR2520SA Feature Summary**

<b>Feature</b>	<b>Description</b>
Power Supply	<ul style="list-style-type: none"><li>• Single 600 W power supply module (SR2520SAF)</li><li>• Redundant 600 W power supply modules (SR2520SAX/SR2520SAXS and SR2520SAXR/SR2520SAXSR)</li></ul>
Fans	<ul style="list-style-type: none"><li>• Three system cooling fans</li><li>• Two non-redundant fans in power supply</li></ul>
System Management	Intel® System Management Software

# Chassis Component Identification

This section helps you identify the components of your server system. If you are near the system, you can also use the Quick Reference Label provided on the inside of the chassis cover to assist in identifying components.

## Internal Components

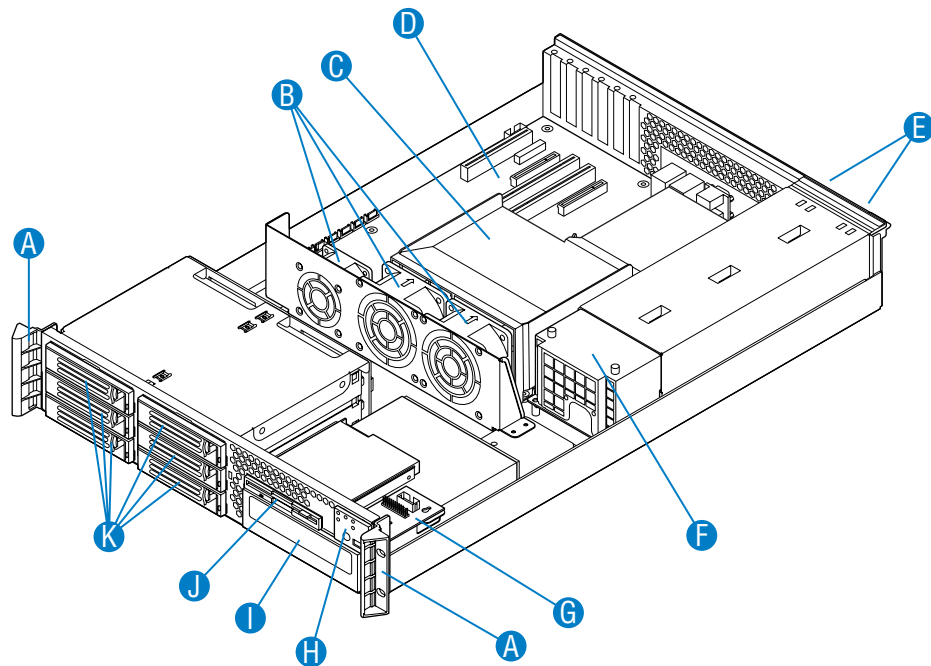

AF001442

A. Rack Handles	G. Front Panel
B. System Cooling Fans	H. Control Panel (standard control panel shown)
C. CPU Air Duct	I. Optical Drive Bay
D. Server Board	J. Slimline Floppy Drive
E. Hot-Swap Power Supplies	K. Hard Drive Bays (drives not included)
F. Hot-Swap Power Cage	

**Figure 2. Chassis Components (SR2520SAX/SR2520SAXS and SR2520SAXR/SR2520SAXSR)**

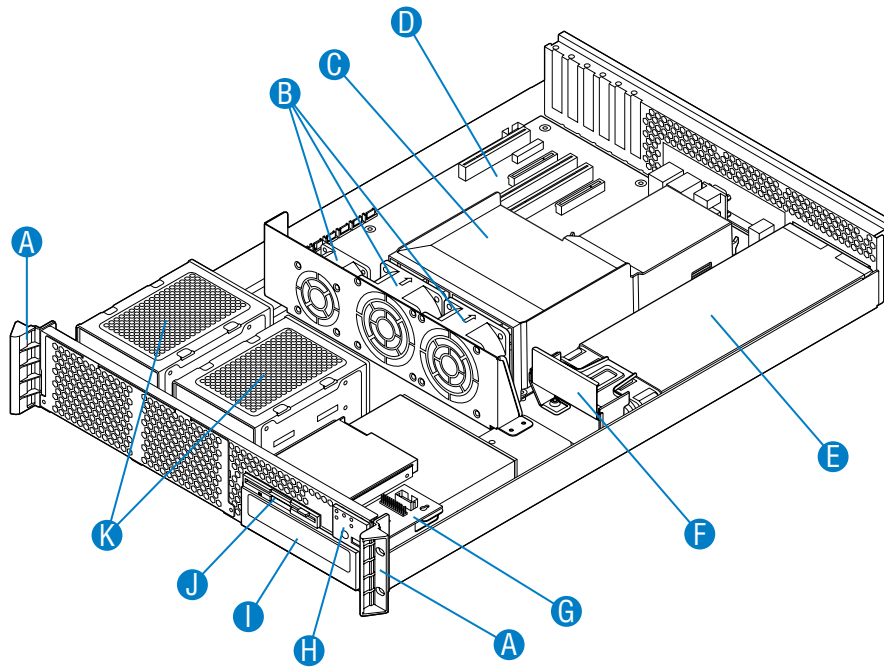

AF001663

A. Rack Handles	G. Front Panel
B. System Cooling Fans	H. Control Panel (standard control panel shown)
C. CPU Air Duct	I. Optical Drive Bay
D. Server Board	J. Slimline Floppy Drive
E. Fixed Power Supply	K. Hard Drive Bays (drives not included)
F. Power Distribution Board	

**Figure 3. Chassis Components (SR2520SAF/SR2520SAFR)**

# Server Board Connector and Component Locations

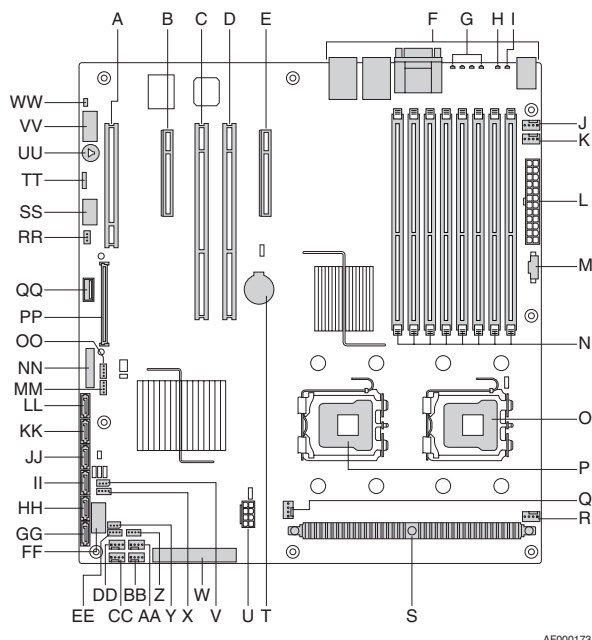

AF000173

**Figure 4. Server Board Connector and Component Locations**

A. PCI 32/33 Slot 1	B. PCIe* x4 Slot 3	C. PCI-X* 64/133 Slot 4
D. PCI-X 64/100 Slot 5	E. PCIe x4 Slot 6	F. Back Panel I/O Ports
G. Diagnostic LEDs (SR2520SAX/ SR2520SAXS and SR2520SAXR/SR2520SAXSR only)	H. System ID LED (SR2520SAX/ SR2520SAXS and SR2520SAXR/SR2520SAXSR only)	I. System Status LED (SR2520SAX/SR2520SAXS and SR2520SAXR/ SR2520SAXSR only)
J. System Fan 6	K. System Fan 5	L. Main Power Connector
M. Auxiliary Signal Connector	N. DIMM Sockets (only 4 on SR2520SAF)	O. Processor 1 Socket
P. Processor 2 Socket	Q. Processor Fan 2 Header	R. Processor Fan 1 Header
S. Processor Voltage Regulator	T. Battery	U. Processor Power Connector
V. IPMB Header	W. SAS RAID 5 Key (SR2520SAX/ SR2520SAXS and SR2520SAXR/SR2520SAXSR only)	X. IDE Connector
Y. LCP Header	Z. SAS_SES2 (SR2520SAX/ SR2520SAXS and SR2520SAXR/SR2520SAXSR only)	AA. SAS SGPIO (SR2520SAX/ SR2520SAXS and SR2520SAXR/SR2520SAXSR only)
BB. System Fan 3	CC. System Fan 4	DD. System Fan 2
EE. System Fan 1	FF. SATA SGPIO	GG. USB 4-5
HH. SATA 0 Connector	II. SATA 1 Connector	JJ. SATA 2/SAS 0 Connector
KK. SATA 3/SAS 1 Connector	LL. SATA 4/SAS 2 Connector	MM. SATA 5/SAS 3 Connector

A. PCI 32/33 Slot 1	B. PCIe* x4 Slot 3	C. PCI-X* 64/133 Slot 4
NN. Backplane Connector B	OO. Front Panel Header	PP. Backplane Connector A
QQ. USB 6 (SR2520SAX/ SR2520SAXS and SR2520SAXR/SR2520SAXSR only)	RR. SATA RAID 5 Key	SS. Speaker
TT. Serial B EMP Connector	UU. Chassis Intrusion	

## Configuration Jumpers

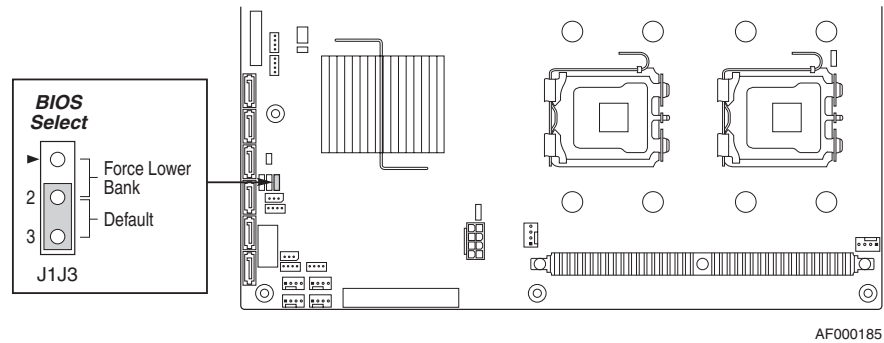

Jumper Name	Jumper Purpose
BIOS Select	If pins 1-2 are jumpered, the BIOS in the lower bank will be selected on the next reset. These pins should be jumpered on 2-3 for normal operation.

**Figure 5. BIOS Select Jumper**

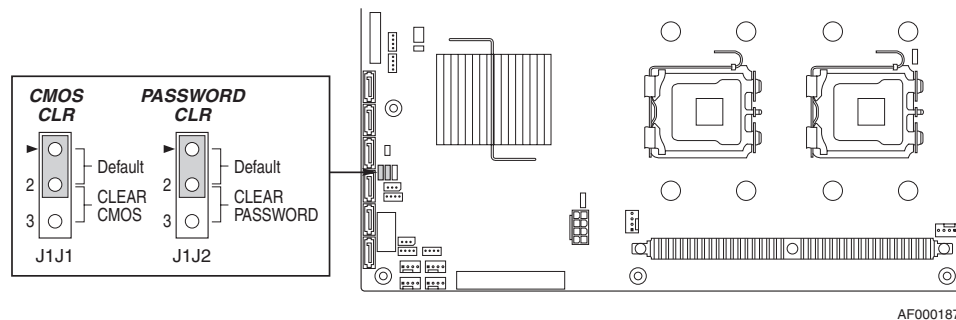



<b>Jumper Name</b>	<b>Jumper Purpose</b>
CMOS Clear	If pins 2-3 are jumpered, the CMOS settings will be cleared on the next reset. These pins should be jumpered on 1-2 for normal operation.
Password Clear	If pins 2-3 are jumpered, administrator and user passwords will be cleared on the next reset. These pins should be jumpered on 1-2 for normal operation.
BMC Force Update Mode	If pins 2-3 are jumpered, BMC Force Update Mode is enabled. These pins should be jumpered on 1-2 for normal operation.

**Figure 6. Recovery Jumpers**

# Intel® Light Guided Diagnostics (SR2520SAX/ SR2520SAXS and SR2520SAXR/SR2520SAXSR Only)

The server board contains diagnostic LEDs to help you identify failed and failing components, and to help you identify the server from among several servers. Except for the ID LED, the status LED, and the 5V standby LED, the LEDs turn on (amber) only if a failure occurs.

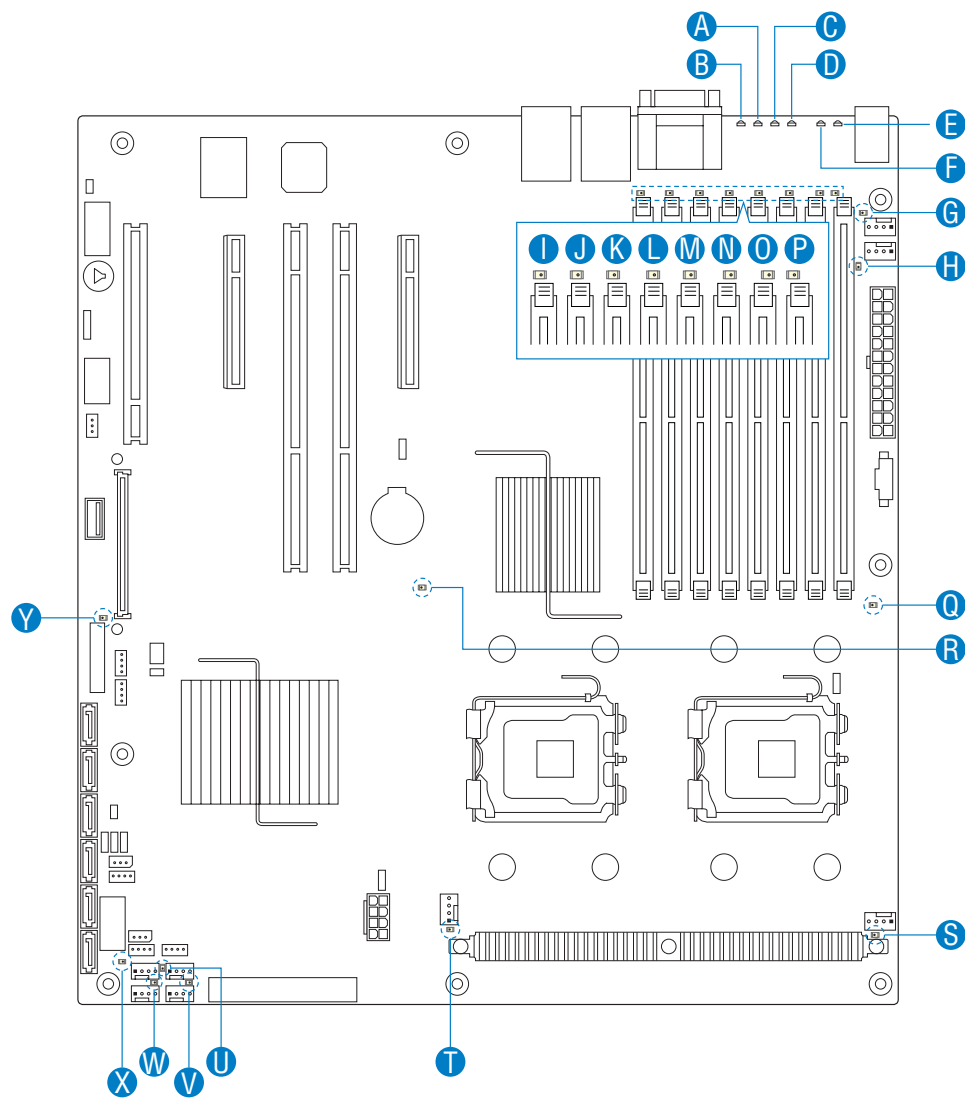

AF000188

**Figure 7. Light Guided Diagnostic LEDs (SR2520SAX/SR2520SAXS and  
SR2520SAXR/SR2520SAXSR)**

# Back Panel Connectors

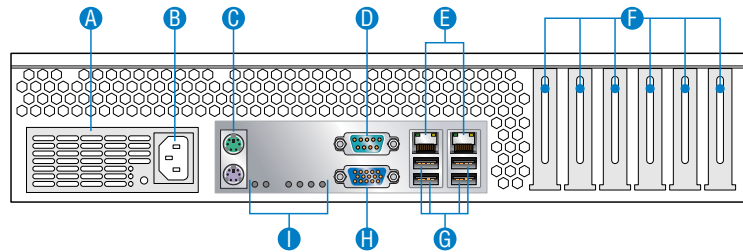

AF001475

A. Power Supply 1 Module	F. PCI Expansion Slots
B. Power Supply 1 Receptacle	G. USB Ports
C. Mouse/Keyboard	H. Video
D. Serial Port A	I. Diagnostic LEDs
E. NIC1 and NIC2 (10/100/1000 Mb)	

**Figure 8. Intel® Server System SR2520SAF/SR2520SAFR Back Panel Connectors**

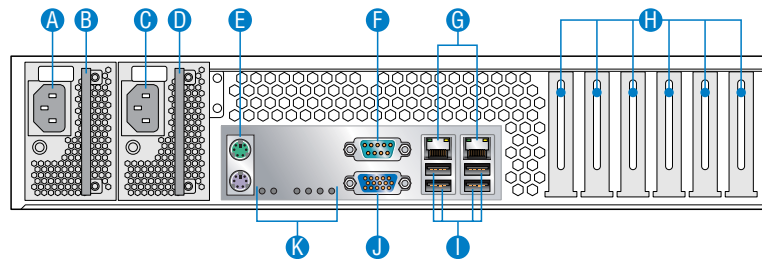

AF001441

A. Power Supply 1 Receptacle	G. NIC1 and NIC2 (10/100/1000 Mb)
B. Power Supply 1 Module	H. PCI Expansion Slots
C. Power Supply 2 Receptacle	I. USB Ports
D. Power Supply 2 Module	J. Video
E. Mouse/Keyboard	K. Diagnostic LEDs
F. Serial Port A	

**Figure 9. Intel® Server System SR2520SAX/SR2520SAXS and SR2520SAXR/SR2520SAXSR Back Panel Connectors**

The NIC LEDs at the right and left of each NIC provide the following information.

**Table 3. NIC LED Descriptions**

LED	LED State	Description
Left	Off	No network connection
	Solid Amber	Network connection in place
	Blinking Amber	Transmit/receive activity
Right	Off	10 Mbps connection (if left LED is on or blinking)
	Solid Amber	100 Mbps connection
	Solid Green	1000 Mbps connection

## Hot-Swap Backplane

The Intel® Server System SR2520SAX/SR2520SAXS and SR2520SAXR/SR2520SAXSR supports a backplane. The backplane provides the platform support for peripheral drives and hot-swap SAS or SATA hard drives. To eliminate several cables, the backplanes are also used as a pathway for signals from the server board to various platform interconnects, including those for the control panel and peripheral drives. The backplane acts as a 'pass-through' for the SAS/SATA data from the drives to the SATA controller on the server board or a SAS/SATA controller add-in card. It provides the physical requirements for the hot-swap capabilities.

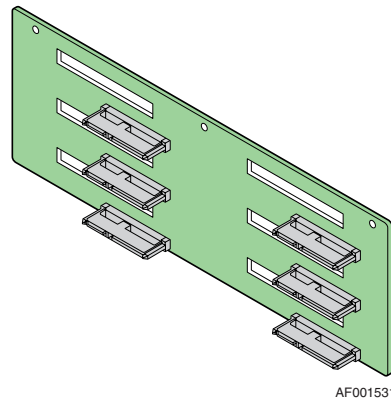

**Figure 10. Hot-Swap Backplane**

**Note:** The Intel® Server System SR2520SAX/SR2520SAXR ships with a passive backplane with 6 SATA cables installed. The Intel® Server System SR2520SAXS/SR2520SAXSR ships with an active backplane with 2 SAS cables installed.

# RAID Support

The Intel® Server System SR2520SA is available in both fixed and redundant models. The fixed model has order code SR2520SAF/SR2520SAFR. The redundant model has order code SR2520SAX/SR2520SAXS and SR2520SAXR/SR2520SAXSR.

For information on configuring RAID, see the RAID Software Guide that is included on the *Intel® Server Deployment Toolkit 2.0 CD*.

## SATA

The Intel® Server Systems SR2520SAF/SR2520SAFR and SR2520SAX/SR2520SAXR provide an embedded SATA controller that supports both 1.5 and 3.0 Gbps data transfer rates.

The BIOS Setup utility provides multiple drive configuration options on the Advanced | ATA Controller setup page, some of which affect the ability to configure RAID. The “Onboard SATA Controller” option is enabled by default. When this option is enabled, the “SATA Mode” option can be set to either Legacy or Enhanced. The Legacy and Enhanced modes affect the RAID configuration as follows:

- Legacy supports four disk drives and does not provide RAID support.
- Enhanced supports six disk drives and is required for RAID configurations.

When the enhanced mode is selected, you can choose to enable or disable “AHCI Mode” or “Configure SATA as RAID”. Intel® Embedded Server RAID Technology II is enabled by the option, “Configure SATA as RAID.” The Intel® Embedded Server RAID Technology II feature provides RAID modes 0, 1, and 10.

For RAID 0, 1, and 10, enclosure management is provided through the SATA\_SGPIO connector on the server board when a cable is attached between this connector on the server board and to the backplane I<sup>2</sup>C interface.

If RAID 5 is desired, the optional Intel® RAID Activation Key AXXRAKSW5 (available post-release) can be installed. To enable RAID 5, this activation key is placed on the SATA\_Key connector that is located at the left side of the server board. For information on how to install the Intel® RAID Activation Key AXXRAKSW5 accessory to enable RAID 5, see the documentation that is included with the accessory kit.

**Notes:** For assistance in navigating through the F2 BIOS Setup utility, see the *Intel® Server Board S5000VSA Technical Product Specification*.

For information on setting up RAID, see the RAID Software Guide that is included on the *Intel® Server Deployment Toolkit 2.0 CD*.

## SAS

In addition to the SATA features described above, the Intel® Server System SR2520SAXS/SR2520SAXSR also has a dual-mode 4-port Serial Attached SCSI (SAS) controller that supports both SAS and SATA hard disk drives. This controller is capable of data transfer rates of up to 3.0 Gbps per port. The SAS controller (in RAID mode) supports eight physical drives and eight logical arrays. The SAS controller (in native mode) supports up to 120 physical drives when expanders are used.

The BIOS Setup utility includes options on the Advanced | Mass Storage setup page to enable or disable the SAS option ROM and the SAS controller. Both of these options must be enabled to use RAID.

- When the SAS controller is enabled, the two black SATA ports on the server board continue to function as SATA ports. The four blue ports can be used as either SAS or SATA ports. When the SAS controller is disabled in the BIOS Setup utility, only the two black SATA ports will be available.
- When the SAS option ROM is enabled in the BIOS Setup utility, Intel® Embedded Server RAID Technology II is available. This enables SAS RAID modes 0, 1, or 10 for the four blue ports on the server board. The SAS controller can mix SAS and SATA drives.

If the SAS option ROM is disabled in the BIOS Setup utility, but the SAS controller is enabled, the four blue ports on the server board continue to function as either SAS or SATA ports and the two black ports on the server board continue to function as SATA-only ports. However, RAID support is not available unless enabled in the BIOS for either SATA or SAS.

SAS server boards can use either or both of the SAS and SATA controllers. Either one or two Intel® RAID Activation Keys AXXRAKSW5 can be installed, one for the SAS controller and/or one for the SATA controller. The RAID controllers have separate configuration utilities available at boot, but they share the Intel® RAID Web Console 2 management utility.

Both SAS and SATA controllers support SGPIO enclosure management. Two SGPIO connectors are available on SAS models of the server board, one for the SAS controller and one for the SATA controller.

If RAID 5 is desired, the optional Intel® RAID Activation Key AXXRAKSW5 (available post-release) can be installed. To enable RAID 5, this activation key is placed on the SAS\_Key connector that is located at the left side of the server board. For information on how to install the Intel® RAID Activation Key AXXRAKSW5 accessory to enable RAID 5, see the documentation that is included with the accessory kit.

**Notes:** For assistance in navigating through the BIOS Setup utility, see the Intel® Server Board S5000VSA Technical Product Specification.

For information on RAID configuration through the BIOS console and Intel® RAID Web Console 2, see the RAID Software Guide.

# Front of Server System

## Control Panel

The diagram below shows the features available on the control panel. .

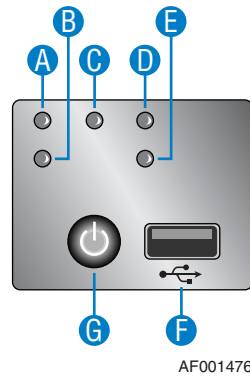

AF001476

Callout	Feature	Function
A.	NIC 1 Activity LED	Continuous green light indicates a link between the system and the network to which it is connected. Blinking green light indicates network activity.
B.	NIC 2 Activity LED	Continuous green light indicates a link between the system and the network to which it is connected. Blinking green light indicates network activity.
C.	Power/Sleep LED	Continuous green light indicates the system has power applied to it. Blinking green indicates the system is in S1 sleep state. No light indicates the power is off / is in ACPI S4 or S5 state.
D.	System Status LED	Solid green indicates normal operation. Blinking green indicates degraded performance. Solid amber indicates a critical or non-recoverable condition. Blinking amber indicates a non-critical condition. No light indicates POST is running or the system is off.
E.	Hard Disk Drive Activity LED	Random blinking green light indicates hard disk drive activity (SAS or SATA). No light indicates no hard disk drive activity.
F.	USB 2.0 Port	Allows you to attach a USB component to the front of the chassis.
G.	Power/Sleep Button	Powers on/off the system. Puts the system in an ACPI sleep state.

**Figure 11. Standard Control Panel**

## Bezels

The optional front bezel provides a snap-on design that allows for maximum airflow through the server chassis. The bezel provides a lock to secure the hard drive and optical drive area. For instructions on installing either of the front bezels, see “[Installing the Front Bezel](#)”.

The order numbers for the bezel is: ADRBEZBLACK.

## Peripheral Devices

The server system provides locations and hardware for installing hard drives, a USB floppy drive, and an optical drive. The drives must be purchased separately. The following figure shows the available options.

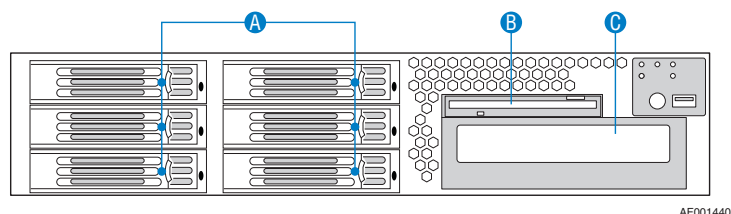

- 
- A. Hard drive bays (drives not included)

---

  - B. Slimline floppy drive

---

  - C. Optical drive bay (Optional; drive not included)

---

**Figure 12. Optional Peripherals (SR2520SAX/SR2520SAXS and SR2520SAXR/SR2520SAXSR)**

The drives must be purchased separately. The following figure shows the available options.

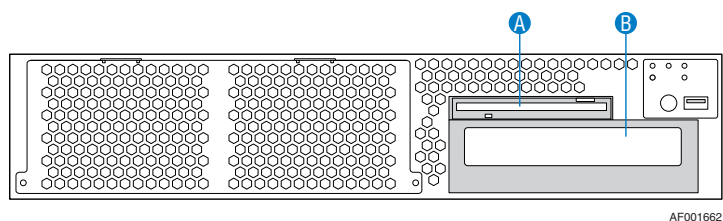

- 
- A. Slimline floppy drive

---

  - B. Optical drive bay (Optional; drive not included)

---

**Figure 13. Optional Peripherals (SR2520SAF/SR2520SAFR)**



## Hard Disk Drives

The server system ships with six drive carriers for installing six SAS or Serial ATA (SATA) hot-swap drives.

For instructions on installing hard drives, see [“Installing and Removing a Hot-swap Hard Drive \(SR2520SAX/SR2520SAXS and SR2520SAXR/SR2520SAXSR\)”](#) or [“Installing and Removing a Fixed Hard Drive \(SR2520SAF/SR2520SAFR\)”](#).

**Note:** *Drives can consume up to 17 watts of power each. Drives must be specified to run at a maximum ambient temperature of 45C.*

**Note:** *The Intel® Server System SR2520SA does not support all SAS or Serial ATA (SATA) hard drives. See [“Server System References”](#) for an Internet link to a list of supported hardware.*

## Rack-Mounted Systems

Your Intel® Server System SR2520SA can be mounted into a rack. Intel provides three options to mount this server into a rack. When installing the chassis into a rack, Intel recommends you install systems from the bottom of the rack to the top. In other words, install the first system in the rack into the bottom position of the rack, the second system in the second position from the bottom, and so on. Instructions for installing your chassis into a rack are included in the rail kit.



# 3 Hardware Installations and Upgrades

---

## Before You Begin

Before working with your server product, pay close attention to the “[Safety Information](#)” at the beginning of this manual.

## Tools and Supplies Needed

- Phillips\* (cross head) screwdrivers (#1 bit and #2 bit)
- Needle nosed pliers
- Antistatic wrist strap and conductive foam pad (recommended)

## System References

All references to left, right, front, top, and bottom assume the reader is facing the front of the server system as it would be positioned for normal operation.

## Removing and Installing from a Rack

Two Intel® rack options are available to install the Intel® Server System SR2520SA in a rack. The options are the fixed bracket kit and the basic rail kit.

***Note:** Follow all safety guidelines while removing a system from a rack to avoid injury.*

### Fixed Bracket Rack Mount Removal

1. Disconnect all cables from the back of the system.

***Note:** Remember to use the system LED to properly identify the system you are servicing.*

2. Remove screws from the brackets and remove the system from the rack.

## Fixed Bracket Rack Mount Installation

1. Fully extend a rail assembly; the finger tab for the extension lock is revealed.
2. Press the finger tab and slide the inside rail from the middle rail until it completely separates.

**Note:** *The middle rail and outer rail cannot be separated.*

3. Position an inside rail along one side of the chassis with the finger tab facing outward and located closer to the rear of the chassis.
4. Align the holes in the rail with the tabs on the chassis and place the rail against the chassis.
5. Slide the rail as far as it will go toward the front of the chassis to engage the tabs.
6. Fasten the rail to the chassis using one screw at the front of the chassis.
7. In the same manner, attach the other inside rail to the other side of the chassis.
8. Using two screws, attach one nut bar to the inside of the rack post. Do not completely tighten the screws; leave them loose enough to allow insertion of the brackets in the next step.
9. Insert the slotted foot of a rail bracket between each nut bar and post.
10. Align the face of the bracket foot with the inside edge of the rack post and firmly tighten the screws.
11. Repeat steps 8 to 10 above to install the other 3 brackets (2 front & 2 back). Ensure all brackets are at the same height on the rack.
12. Position a rail assembly (middle and outer rails) with its black plastic end caps toward the rear of the rack and its outer rail closest to the brackets.
13. Align the front screw hole in the outer rail with the threaded hole nearest the front of the front bracket and fit the rail assembly into the front and rear brackets.
14. Slide the middle rail toward the front until the access hole in the middle rail is aligned with the front screw hole in the outer rail.
15. Insert screw through the access hole and loosely attach the outer rail to the front bracket.
16. In a similar manner to steps 13 through 15, install a screw through a slot in the outer rail and into the rear-most threaded hole in the front bracket. Firmly tighten this screw.
17. Firmly tighten the front screw installed loosely in step 15.
18. In the same manner, attach the other rail assembly to the other side.
19. Slide the middle rail toward the front until the rear bracket area is accessible.
20. Attach the rear end of the outer rail to the rear bracket with at least one screw. If possible, attach at two places.
21. In the same manner, attach the other rail assembly to the other side.

22. Fully extend the left and right rails until the extension locks have engaged and the rails will not push back in. The rail system is now ready to receive the chassis.

**Caution:** *Lifting and placing the chassis in the rails is a two-person job. If needed, use an appropriate lifting device.*

23. With the chassis front facing you, lift the chassis and carefully insert the rails attached to the chassis in the extended rails.
24. Slide the chassis toward the rear of the cabinet until the rails lock together.
25. Depress and hold down the finger tabs on both extension locks while sliding the chassis toward the rear.
26. Slide the chassis all the way into the rack until the chassis handles are against the front posts.

## Basic Rail Rack Mount Removal

1. Disconnect all cables from the back of the system.

**Note:** *Remember to use the system LED to properly identify the system you are servicing.*

2. Pull system from rack until brackets are fully extended.
3. Push in both clips on the brackets and slide the system forward until the inner rail separates from the outer rail.
4. Remove and service the system.

## Basic Rail Rack Mount Installation

1. Extend the inner rail until it locks.
2. Depress the spring safety lock to release the inner rail.
3. Remove the inner rail from the rail assembly.
4. Attach the outer rail slides to the rack posts using two #10-32 x 1/2 screws at the front posts, and two #10-32 x 1/2 screws at the rear posts.

**Note:** *The rail flanges mount to the inside of each post.*

5. Insert the inner rails over the server chassis sidewall studs.
6. Slide the inner rails toward the front of the server chassis.
7. Secure the inner rails with one #6-32 x 1/4 screw for each rail.
8. Align the inner rails (attached to the server chassis) with the outer rail assemblies (attached to the rack).
9. Engage the matching rails and slide the server chassis into the rack until the two safety stops lock into position.
10. Depress the two safety locks (one on each side).

11. Slide the server chassis all the way into the rack.
12. Use the rack screws (#10-32 x 3/4) to secure the chassis and rack handles into the rack.

## Removing and Installing the Front Bezel

The front bezel is available as optional accessories for the Intel® Server System SR2520SA. Note the orientation in the figure below - the control panel is at the right. If you are installing a bezel on your server system, make sure you position it as shown.

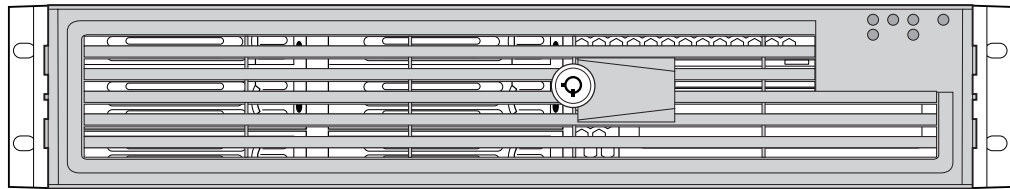

AF001471

**Figure 14. Front View with Bezel**

## Removing the Front Bezel

Use the steps below if your system includes a front bezel.

1. Unlock the bezel.
2. Pull the bezel from the server system.

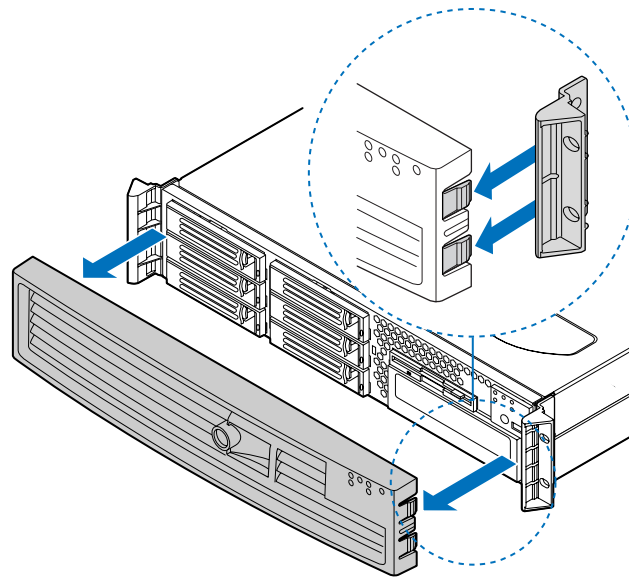

AF001444

**Figure 15. Removing the Front Bezel**

## Installing the Front Bezel

Use the steps below if your system includes either the standard front bezel or the front bezel for the Intel® Local Control Panel. The front bezel is optional.

1. At each end of the bezel, line up the center notch on the bezel with the center guide on the rack handles.
2. Push the bezel onto the front of the server system until it clicks into place.

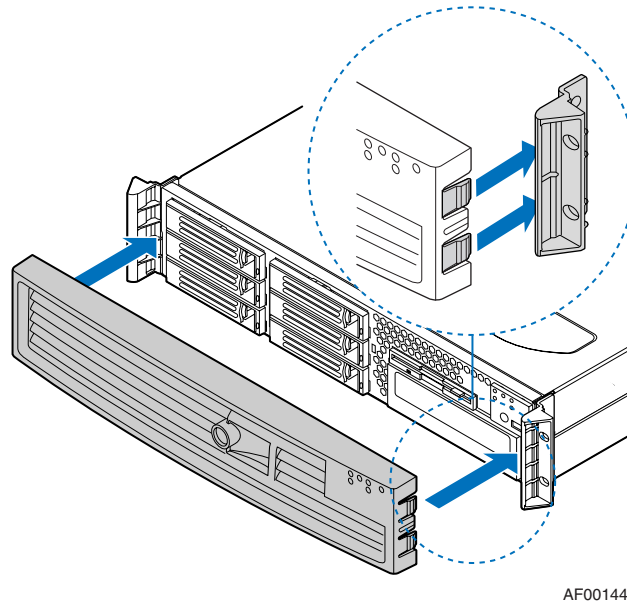

Figure 16. Installing the Front Bezel

## Removing and Installing the System Cover

### Removing the System Cover

The server system must be operated with the system cover in place to ensure proper cooling. You will need to remove the top cover to add or replace components inside of the server. Before removing the chassis cover, power down the server and unplug all peripheral devices and the AC power cable(s).

**Note:** A nonskid surface or a stop behind the server system may be needed to prevent the server system from sliding on your work surface.

1. Observe the safety and ESD precautions at the beginning of this book. See “[Safety Information](#)”.
2. Turn off all peripheral devices connected to the server. Turn off the server.
3. Disconnect the AC power cord(s).



4. Remove the top cover screws. See letter "A" in the figure below.
5. While holding in the blue button at the top of the server system in (see letter "B"), slide the top cover back until it stops.
6. Insert your finger in the notch (see letter "C") and lift the cover upward to remove it.

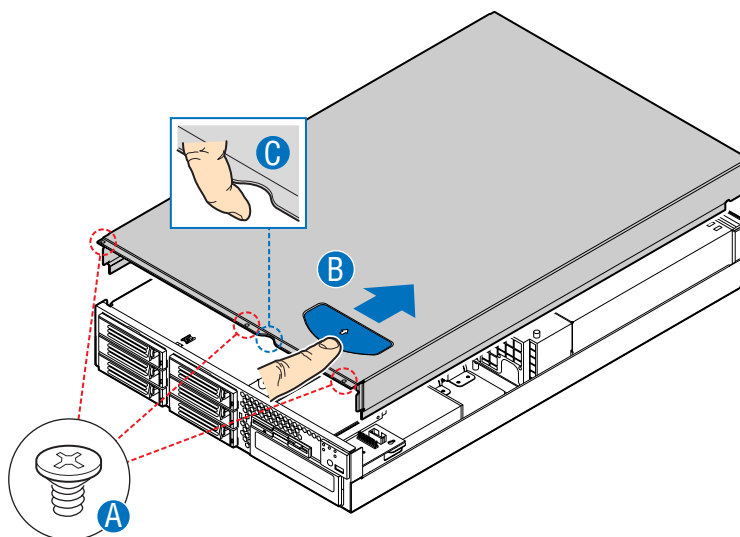

AF001445

**Figure 17. Removing the Server System Cover**

## Installing the System Cover

1. Place the cover over the server system so that the side edges of the cover sit just inside the server system sidewalls.
2. Slide the cover forward until it clicks into place (see letter "A").
3. Insert the screws at the three locations in the top cover (see letter "B").
4. Reconnect all peripheral devices and the AC power cord(s).

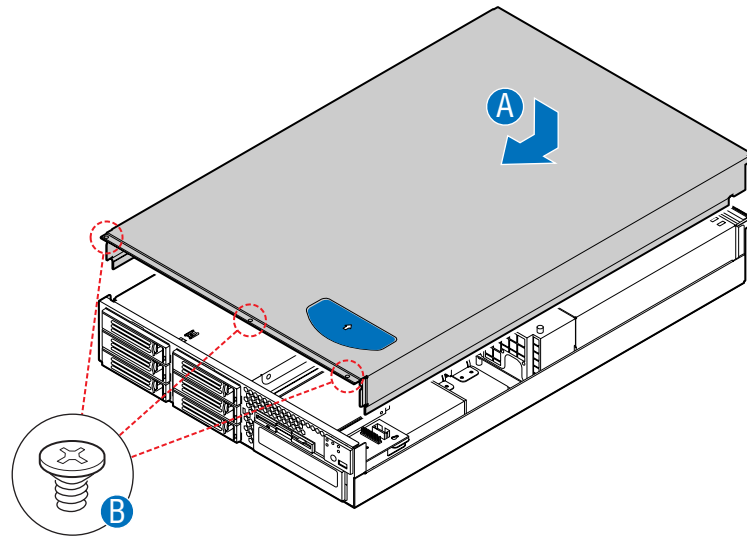

AF001446

**Figure 18. Installing the Server System Cover**

## Removing and Installing the Processor Air Duct

Always operate your server system with the processor air duct in place. The air duct is required for proper airflow within the server system.

For instructions on adding or replacing a processor, first remove the processor air duct, and then see your server board user guide for instructions on processor installations and removals. Return to these instructions to reinstall the processor air duct after installing your processor and heat sink.

### Removing the Processor Air Duct

1. Observe the safety and ESD precautions at the beginning of this book. See "[Safety Information](#)".
2. Power down the server and unplug all peripheral devices and the AC power cable.
3. Remove the server system cover. For instructions, see "[Removing the System Cover](#)".
4. Lift the processor air duct from its location over the two processor sockets.

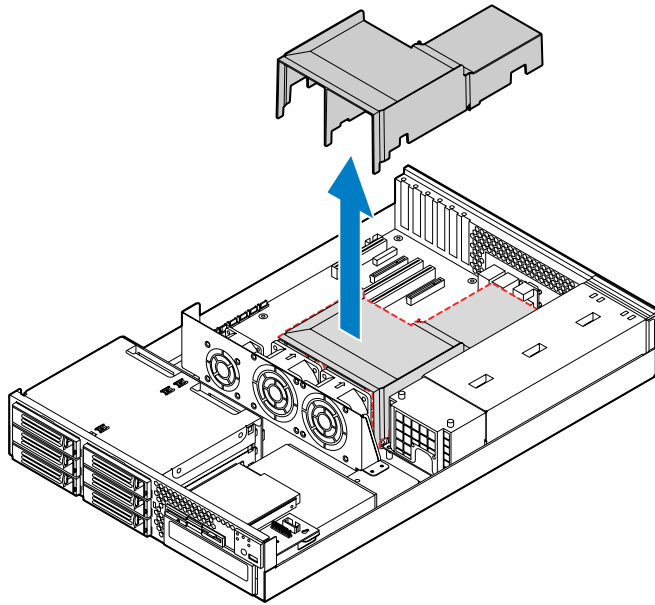

AF001447

**Figure 19. Removing the Processor Air Duct**

## Installing the Processor Air Duct

1. Observe the safety and ESD precautions at the beginning of this book. See "[Safety Information](#)".
2. Power down the server and unplug all peripheral devices and the AC power cable(s).
3. Remove the server system cover. For instructions, see "[Removing the System Cover](#)".
4. Place the processor air duct over the processor socket(s). See the figure below. The front edge of the air duct should contact the fan module. Use caution not to pinch or disengage cables that may be near or under the air duct.

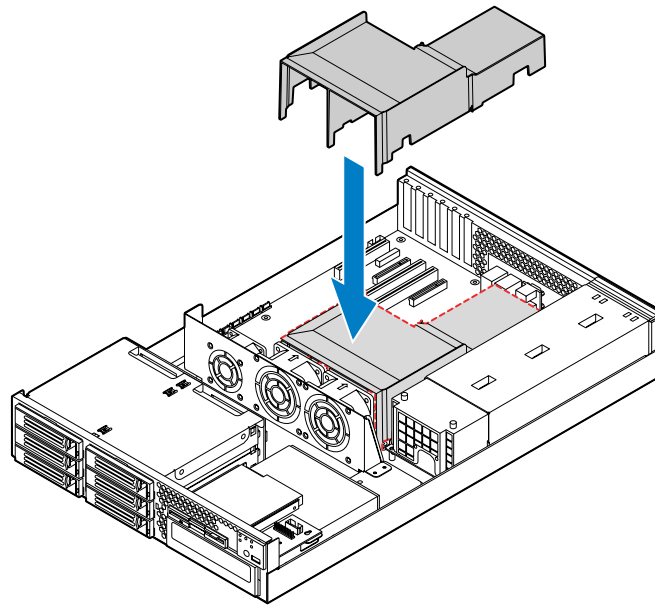

AF001448

**Figure 20. Installing the Processor Air Duct**

5. Install the server system cover. For instructions, see "[Installing the System Cover](#)".
6. Plug all peripheral devices and the AC power cable(s) into the server.

# Installing and Removing Memory

The silkscreen on the board for the DIMMs displays DIMM A1, DIMM A2, DIMM B1, DIMM B2, DIMM C1, DIMM C2, DIMM D1 and DIMM D2 starting from the center of the board. See "Memory" for a discussion of the memory requirements and options. See ["Server System References"](#) for a link to the list of tested DIMMs.

*Note:* The Intel® Server System SR2520SAF/SR2520SAFR only has four DIMM sockets.

## Installing DIMMs

To install DIMMs, follow these steps:

1. Observe the safety and ESD precautions in ["Safety Information"](#).
2. Turn off all peripheral devices connected to the server. Turn off the server.
3. Disconnect the AC power cord(s) from the server.
4. Remove the system's cover. For instructions, see ["Removing the System Cover"](#).
5. Locate the DIMM sockets (see [Figure 21](#)).

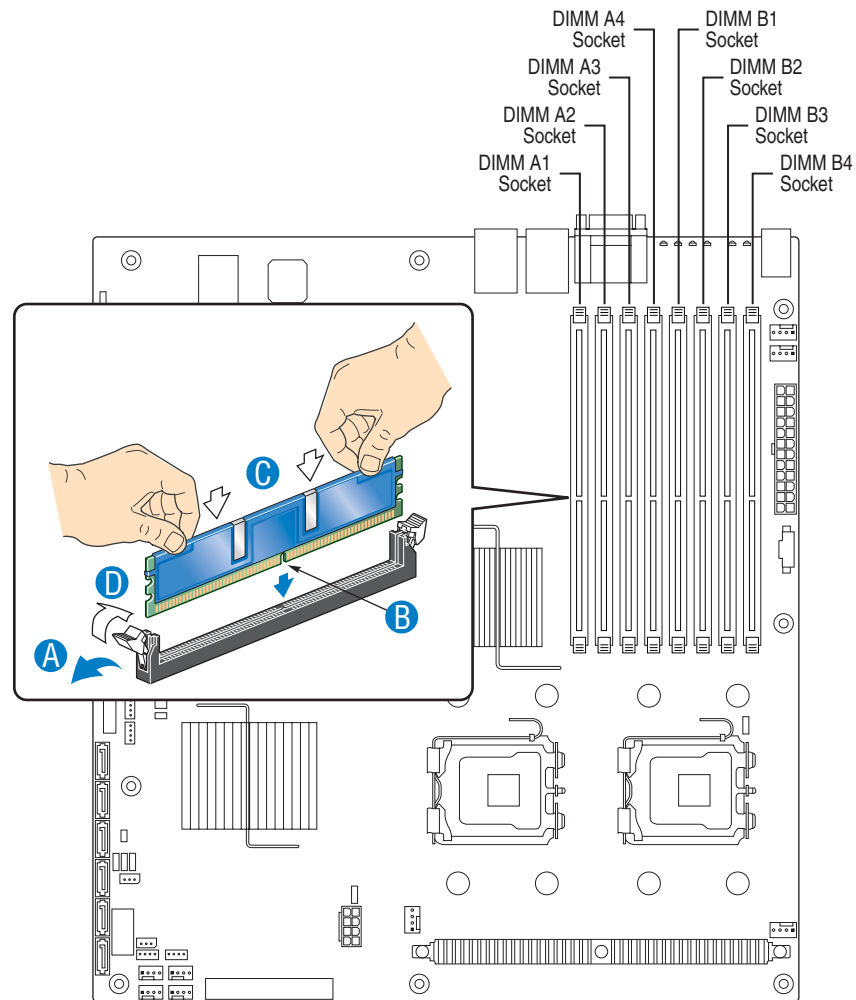

AF000174

**Figure 21. Installing the Memory**

6. Make sure the clips at either end of the DIMM socket(s) are pushed outward to the open position (see letter “A” in the figure above).
7. Holding the DIMM by the edges, remove it from its anti-static package.
8. Position the DIMM above the socket. Align the notch on the bottom edge of the DIMM with the key in the DIMM socket. The arrow in the inset in [Figure 21](#) is pointing to the key in the socket (see letter “B” in the figure above).
9. Insert the bottom edge of the DIMM into the socket.
10. When the DIMM is inserted, push down on the top edge of the DIMM until the retaining clips snap into place (see letter “C” in the figure above). Make sure the clips are firmly in place (see letter “D” in the figure above).

11. Replace the system's cover and reconnect the AC power cord(s). For instructions on installing the system's cover, see [“Installing the System Cover”](#).

## Removing DIMMs

To remove a DIMM, follow these steps:

1. Observe the safety and ESD precautions in [“Safety Information”](#).
2. Turn off all peripheral devices connected to the server. Turn off the server.
3. Remove the AC power cord(s) from the server.
4. Remove the server's cover. See the documentation that came with your server chassis for instructions on removing the server's cover.
5. Gently spread the retaining clips at each end of the socket. The DIMM lifts from the socket.
6. Holding the DIMM by the edges, lift it from the socket, and store it in an anti-static package.
7. Reinstall and reconnect any parts you removed or disconnected to reach the DIMM sockets.
8. Replace the system's cover and reconnect the AC power cord(s). For instructions on installing the system's cover, see [“Installing the System Cover”](#).

## Installing or Replacing the Processor

**Caution:** *Processor must be appropriate: You may damage the server board if you install a processor that is inappropriate for your server. See [“Server System References”](#) for a link to the list of compatible processor(s).*

**Caution:** *ESD and handling processors: Reduce the risk of electrostatic discharge (ESD) damage to the processor by doing the following: (1) Touch the metal chassis before touching the processor or server board. Keep part of your body in contact with the metal chassis to dissipate the static charge while handling the processor. (2) Avoid moving around unnecessarily.*

**Caution:** *Protective socket cover needs to be removed for proper cooling of the processor; failure to remove the cover could result in damage to the system.*

## Installing the Processor

To install a processor, follow these instructions:

1. Observe the safety and ESD precautions in [“Safety Information”](#).
2. Turn off all peripheral devices connected to the server. Turn off the server.
3. Disconnect the AC power cord(s) from the server.

4. Remove the system's cover. For instructions, see [“Removing the System Cover”](#).
5. Remove the processor air duct. For instructions, see [“Removing the Processor Air Duct”](#).
6. Remove the heat sink, if installed.
7. Locate the processor socket and raise the socket handle completely (see [Figure 22](#)).

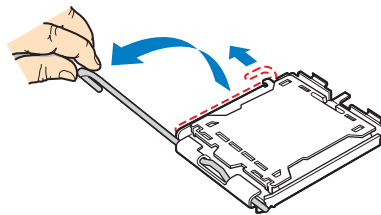

**Figure 22. Lifting the Processor Socket Handle**

8. Raise the CPU load plate (see [Figure 23](#)).

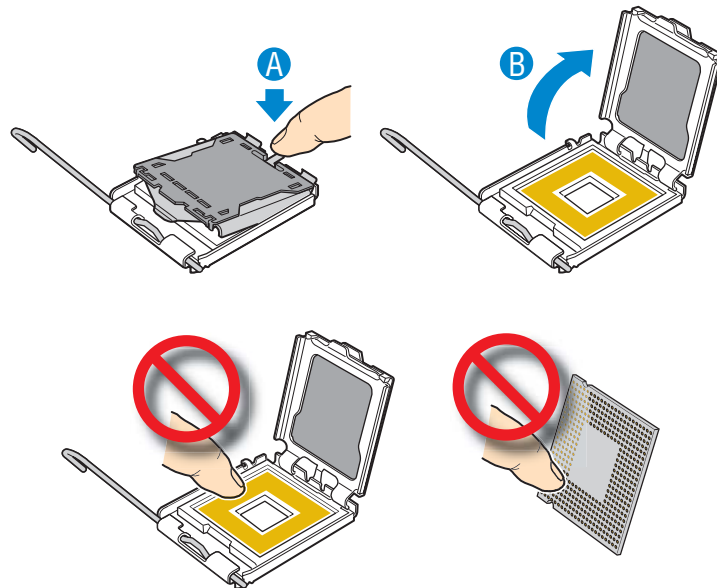

**Figure 23. Installing the Processor**

**Note:** Do not touch the socket pins; they are very sensitive and easily damaged.

9. Line up the alignment marks on the processor and the socket, and insert the processor into the socket.

**Note:** Make sure the alignment triangle mark and the alignment triangle cutout align correctly.



10. Remove the protective socket cover (see [Figure 24](#)).

**Note:** Retain the protective socket cover for use when removing a processor that will not be replaced.

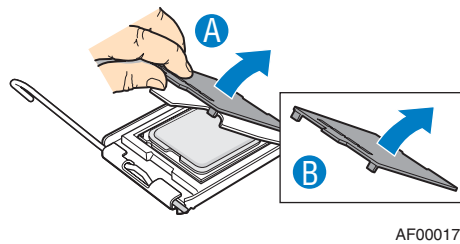

**Figure 24. Removing the Socket Cover**

11. Lower the CPU load plate and lower the socket lever completely.

## Installing the Heat Sink(s)

The heat sink has Thermal Interface Material (TIM) located on the bottom of it. Use caution when you unpack the heat sink so you do not damage the TIM.

1. Set the heat sink over the processor, lining up the four captive screws with the four posts surrounding the processor.
2. Loosely screw in the captive screws on the heat sink corners in a diagonal manner. Do not fully tighten one screw before tightening another.
3. Gradually and equally tighten each captive screw until each is firmly tightened.

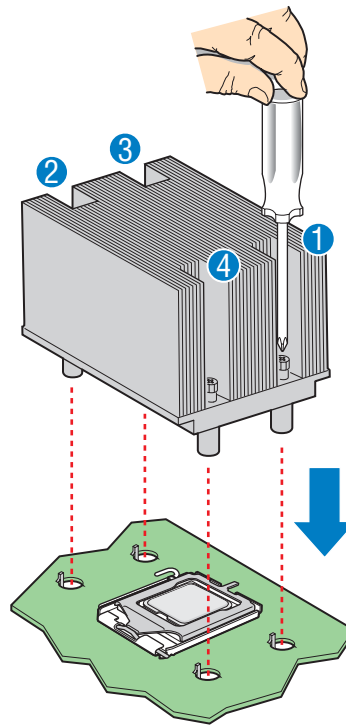

AF000179

**Figure 25. Installing the Heat Sink (2U Passive Heat Sink Shown)**

4. Reinstall and reconnect any parts you removed or disconnected to reach the processor sockets.
5. Replace the system's cover and reconnect the AC power cord(s). For instructions on installing the system's cover, see [“Installing the System Cover”](#).

## Removing a Processor

1. Observe the safety and ESD precautions in [“Safety Information”](#).
2. Turn off all peripheral devices connected to the server. Turn off the server.
3. Remove the AC power cord(s) from the server.
4. Remove the server's cover. See the documentation that came with your server chassis for instructions on removing the server's cover.
5. Loosen the four captive screws on the corners of the heat sink.
6. Twist the heat sink slightly to break the seal between the heat sink and the processor.
7. Lift the heat sink from the processor. If it does not pull up easily, twist the heat sink again. Do not force the heat sink from the processor. Doing so could damage the processor.
8. Lift the processor lever.

9. Raise the CPU load plate.
10. Remove the processor.
11. If installing a replacement processor, see [“Installing the Processor”](#). Otherwise, install the protective socket cover over the empty processor socket and reinstall the system’s cover.

## Installing and Removing a Hot-swap Hard Drive (SR2520SAX/SR2520SAXS and SR2520SAXR/SR2520SAXSR)

Up to six hot-swap SATA drives or SAS drives can be installed.

**Cautions:** *If you install less than six drives or devices, the empty drive bays must be occupied by carriers with baffles to maintain proper system cooling.*

*To avoid possible damage to your server system, do not use older style drive carriers.*

**Note:** *The server system does not support all hard drives. See [“Server System References”](#) for an Internet link to a list of supported hardware.*

## Installing a SAS or SATA Hot-swap Hard Disk Drive (SR2520SAX/SR2520SAXS and SR2520SAXR/SR2520SAXSR)

1. Remove the front bezel if it is installed. For instructions, see [“Removing the Front Bezel”](#).
2. Open the green latch at the front of the hard drive carrier.
3. Pull out on the black lever and slide the carrier from the server system.

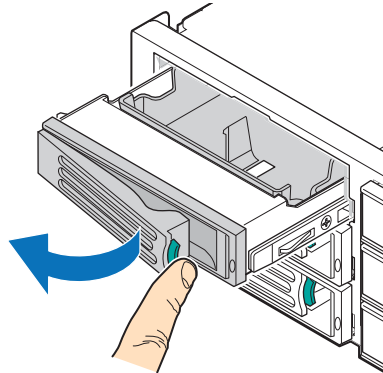

AF001450

**Figure 26. Removing Hot-swap Disk Carrier from the Server System  
(SR2520SAX/SR2520SAXS and SR2520SAXR/SR2520SAXSR)**

4. Remove the four screws that attach the plastic retention device or the previously installed hard drive to the drive carrier. Two screws are at each side of the retention device or the hard drive. Store the plastic retention device for future use. See letter “A” in the figure below.
5. Remove the hard drive from its wrapper and place it on an antistatic surface.
6. Set any jumpers and/or switches on the drive according to the drive manufacturer's instructions.
7. With the drive circuit-side down, position the connector end of the drive so that it is facing the rear of the drive carrier.
8. Align the holes in the drive to the holes in the drive carrier and attach it to the carrier with the screws that were attached to the plastic retention device. See letter “B” in the figure below.

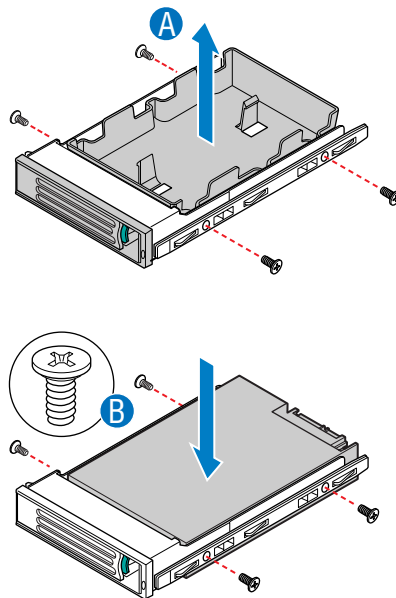

AF001451

**Figure 27. Removing Retention Device from Drive Carrier (SR2520SAX/ SR2520SAXS and SR2520SAXR/SR2520SAXSR)**

9. With the black lever in the fully open position, slide the drive assembly into the server system (see letter “A” in the figure below). The green latch at the front of the drive carrier must be to the right. Do not push on the black drive carrier lever until the lever begins to close by itself.
10. When the black drive carrier lever begins to close by itself, push on it to lock the drive assembly into place (see letter “B” in the figure below).



## Removing a SAS or SATA Hot-swap Hard Disk Drive (SR2520SAX/SR2520SAXS and SR2520SAXR/SR2520SAXSR)

1. Remove the front bezel if it is installed. For instructions, see [“Removing the Front Bezel”](#).
2. Press in on the green latch at the front of the hard drive carrier.
3. Pull out on the black lever to slide the carrier from the server system.
4. Remove the four screws that attach the hard drive to the drive carrier. Lift the drive from the carrier. Store the drive in an anti-static bag.
5. If you are not installing a new drive, place the plastic retention device into the drive carrier, using the four screws you removed from the hard drive.
6. Insert the screws that held the drive in the carrier into the screw locations on the carrier for future use.
7. With the black lever in the fully open position, slide the drive carrier into the server system. The green latch must be to the right. Do not push on the black lever until the lever begins to close by itself.

**Note:** For proper airflow, the hard drive carrier must be replaced in the server system, even if no hard drive is installed in it.

8. When the black lever begins to close by itself, push on it to lock the drive carrier into place.
9. Install the server system cover. For instructions, see [“Installing the System Cover”](#).
10. (Optional) Install the front bezel. For instructions, see [“Installing the Front Bezel”](#).
11. Plug all peripheral devices and the AC power cable(s) into the server.

## Installing and Removing a Fixed Hard Drive (SR2520SAF/SR2520SAFR)

Up to six fixed SATA drives can be installed.

**Note:** The server system does not support all hard drives. See [“Server System References”](#) for an Internet link to a list of supported hardware.

### Installing a Fixed Hard Disk Drive (SR2520SAF/SR2520SAFR)

1. Remove the server system cover.

2. Remove the four screws securing the hard drive bracket in place (see letter “A” in the figure below). Save the screws; you will use them to install the hard drive bracket back into the server system.
3. Remove the hard drive bracket from the server system.
4. Install the hard drive(s) into the hard drive bracket using four screws (see letter “B” in the figure below).

**Note:** Install screws into the round holes first, then the slotted holes.

5. When all hard drives have been installed in the hard drive cage, reinstall the hard drive bracket and secure into the server system with the four screws you removed in step 2 (see letter “C” in the figure below).

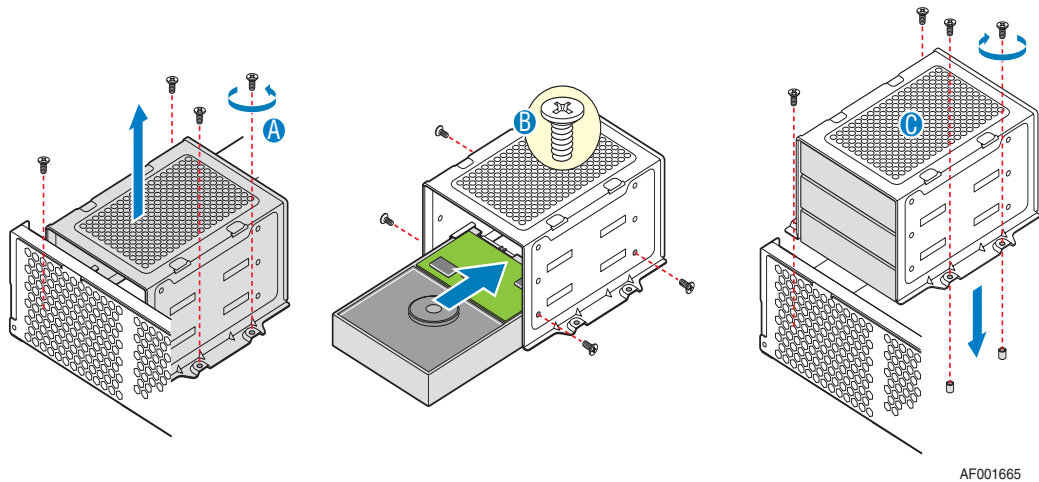

**Figure 29. Installing Fixed Hard Drive(s) into the Server System (SR2520SAF/SR2520SAFR)**

6. Install the server system cover. For instructions, see “Installing the System Cover”.
7. Plug all peripheral devices and the AC power cable(s) into the server.



## Removing a Fixed Hard Disk Drive (SR2520SAF/SR2520SAFR)

1. Remove the server system cover.
2. Remove the four screws that attach the hard drive cage to the server system (see letter “A” in the figure below) and remove the hard drive cage.
3. Remove the four screws that attach the hard drive to the drive cage. Remove the drive from the hard drive cage (see letter “B” in the figure below). Store the drive in an anti-static bag.

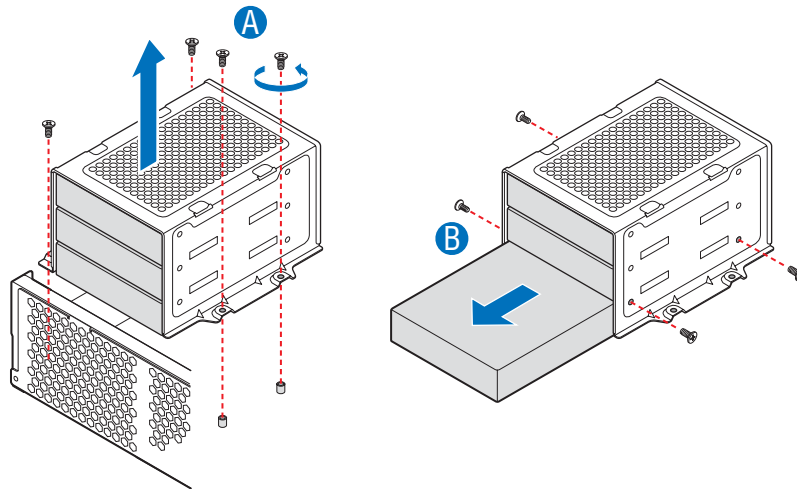

AF001646

**Figure 30. Removing Fixed Hard Drive(s) from the Server System (SR2520SAF/SR2520SAFR)**

4. Insert the screws that held the drive in the carrier into the screw locations on the hard drive cage for future use.
5. Using the four screws you removed in step 2, secure the hard drive cage into the server system.
6. Install the server system cover. For instructions, see [“Installing the System Cover”](#).
7. Plug all peripheral devices and the AC power cable(s) into the server.

# Installing or Removing the Optical Drive

**Cautions:** The optical drive is NOT hot swappable. Before removing or replacing the drive, you must first take the server out of service, turn off all peripheral devices connected to the system, turn off the system by pressing the power button, and unplug the AC power cord from the system or wall outlet.

## Installing the Optical Drive

1. Observe the safety and ESD precautions at the beginning of this book. See [“Safety Information”](#).
2. Power down the server and unplug all peripheral devices and the AC power cable(s).
3. Remove the front bezel if it is installed. For instructions, see [“Removing the Front Bezel”](#).
4. Remove the server system cover. For instructions, see [“Removing the System Cover”](#).
5. Remove the front panel. For instructions, see [“Replacing the Front Panel Board”](#).
6. Remove the four screws holding the drive bracket to the server system (see letter “A” in the figure below), and remove the bracket from the system (see letter “B” in the figure below).

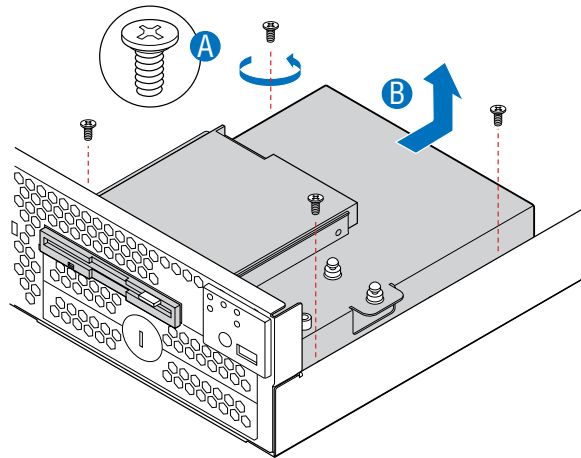

AF001825

**Figure 31. Removing Drive Bracket from the Server System**

7. Install the optical drive to the drive bracket (see letter “A” in the figure below) and secure it with four screws (see letter “B” in the figure below).

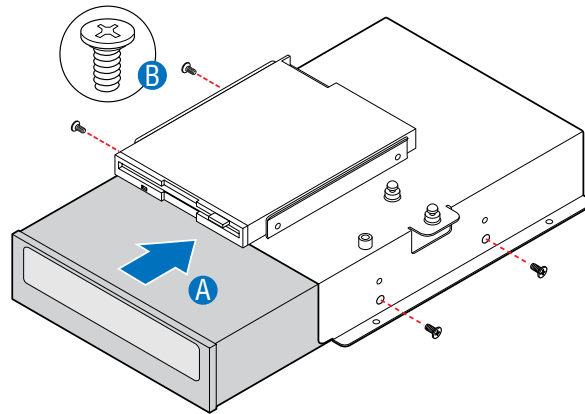

AF001826

**Figure 32. Installing Optical Drive into the Drive Bracket**

8. First time installation: remove the optical drive knockout in the chassis sheet metal as shown in the figure below.

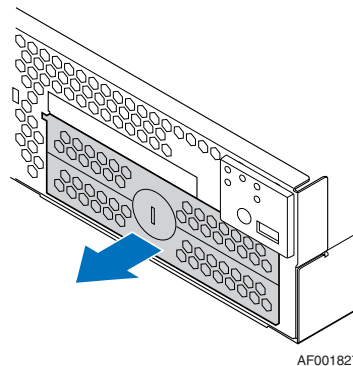

AF001827

**Figure 33. Removing Optical Drive Knockout**

9. Lower the drive bracket into the system and slide it forward into place (see letter “A” in the figure below).
10. Secure the drive bracket into place with four screws (see letter “B” in the figure below).

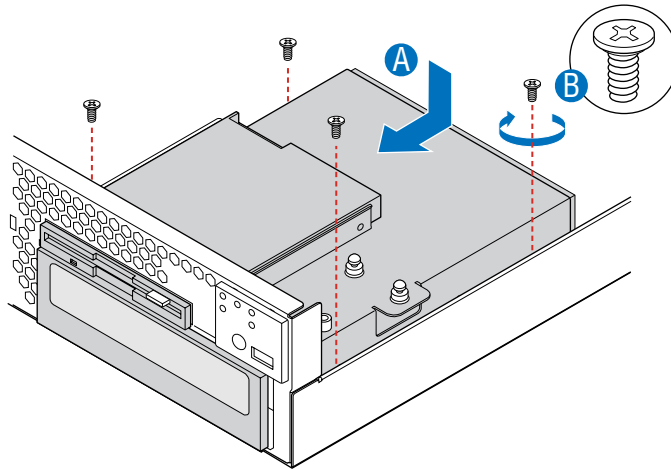

AF001828

**Figure 34. Installing Optical Drive and Drive Bracket into Server System**

11. Reinstall the front panel board. For instructions, see [“Replacing the Front Panel Board”](#).
12. Obtain the cable from the accessory kit and install the cable to the drive and the server board.
13. Install the server system cover. For instructions, see [“Installing the System Cover”](#).
14. (Optional) Install the front bezel. For instructions, see [“Installing the Front Bezel”](#).
15. Plug all peripheral devices and the AC power cable(s) into the server.

## Removing the Optical Drive

1. Observe the safety and ESD precautions at the beginning of this book. See [“Safety Information”](#).
2. Power down the server and unplug all peripheral devices and the AC power cable(s).
3. Remove the front bezel if it is installed. For instructions, see [“Removing the Front Bezel”](#).
4. Remove the server system cover. For instructions, see [“Removing the System Cover”](#).
5. Remove the front panel. For instructions, see [“Replacing the Front Panel Board”](#).
6. Remove the four screws holding the drive bracket to the server system (see letter “A” in the figure below), and remove the bracket from the system (see letter “B” in the figure below).

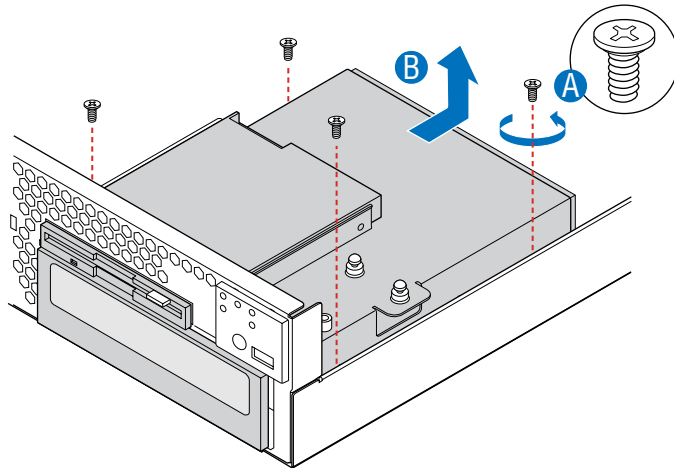

AF001829

**Figure 35. Removing Drive Bracket and Optical Drive from the Server System**

7. Remove the screws securing the optical drive in place (see letter “A” in the figure below) and remove the optical drive (see letter “B” in the figure below).

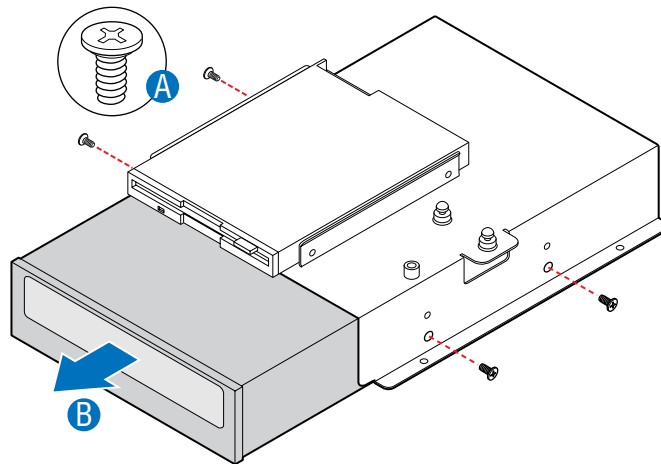

AF001830

**Figure 36. Removing Optical Drive from Drive Bracket**

8. Install replacement drive. For instructions, see “Installing the Optical Drive”.
9. Install the server system cover. For instructions, see “Installing the System Cover”.
10. (Optional) Install the front bezel. For instructions, see “Installing the Front Bezel”.
11. Plug all peripheral devices and the AC power cable(s) into the server.

# Installing and Removing a PCI Add-in Card

The instructions below describe how to install and remove a PCI add-in card.

## Installing a PCI Add-in Card

1. Observe the safety and ESD precautions at the beginning of this book. See [“Safety Information”](#).
2. Power down the server and unplug all peripheral devices and the AC power cable(s).
3. Remove the server system cover. For instructions, see [“Removing the System Cover”](#).
4. Remove the processor air duct. For instructions, see [“Removing the Processor Air Duct”](#).
5. Remove the screw from the selected back panel slot (see letter “A”).
6. Remove the filler panel from the selected add-in card slot by pushing it with your finger (see letter “B”).
7. Insert add-in card until it seats in the slot connector (see letter “C”).
8. Secure add-in card with screw as shown (see letter “D”).

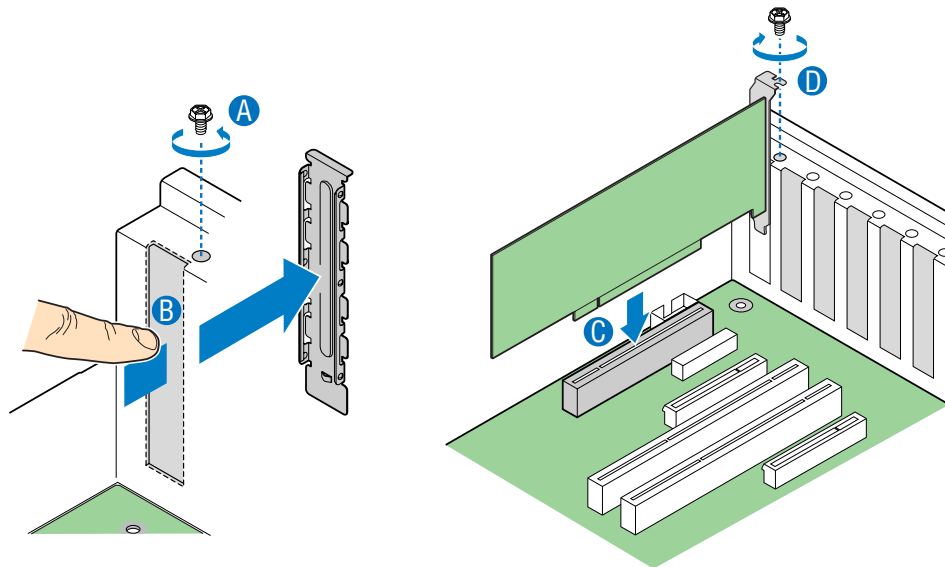

AF001453

**Figure 37. Installing an Add-In Card**

**Note:** Make sure that all empty add-in card slots have filler panels installed.

9. Install the processor air duct. For instructions, see [“Installing the Processor Air Duct”](#).
10. Install the server system cover. For instructions, see [“Installing the System Cover”](#).
11. Plug all peripheral devices and the AC power cable(s) into the server.

## Removing a PCI Add-in Card

1. Observe the safety and ESD precautions at the beginning of this book. See [“Safety Information”](#).
2. Power down the server and unplug all peripheral devices and the AC power cable(s).
3. Remove the server system cover. For instructions, see [“Removing the System Cover”](#).
4. Remove the processor air duct. For instructions, see [“Removing the Processor Air Duct”](#).
5. Remove the screw from the selected back panel slot (see letter “A”).
6. Remove the PCI add-in card from the riser card connector (see letter “B”).

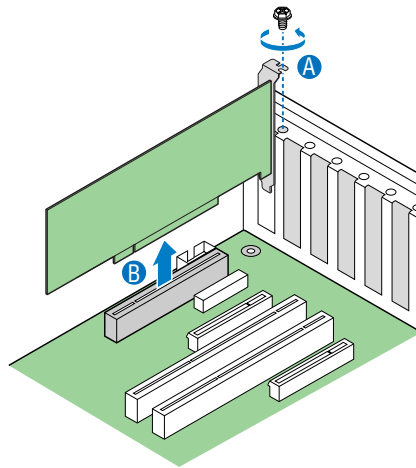

**Figure 38. Removing an Add-In Card**

**Note:** Make sure that all empty add-in card slots have filler panels installed.

7. Install the processor air duct. For instructions, see [“Installing the Processor Air Duct”](#).
8. Install the server system cover. For instructions, see [“Installing the System Cover”](#).
9. Plug all peripheral devices and the AC power cable(s) into the server.

# Installing and Removing the Server Board

## Installing the Server Board

1. Observe the safety and ESD precautions at the beginning of this book. See [“Safety Information”](#).
2. Power down the server and unplug all peripheral devices and the AC power cable(s).
3. Remove the server system cover. For instructions, see [“Removing the System Cover”](#).
4. Remove the processor air duct. For instructions, see [“Removing the Processor Air Duct”](#).
5. Place the server board into the server system as shown in the figure below (see letter “A”).
6. Attach the server board with eight screws (see letter “B”).

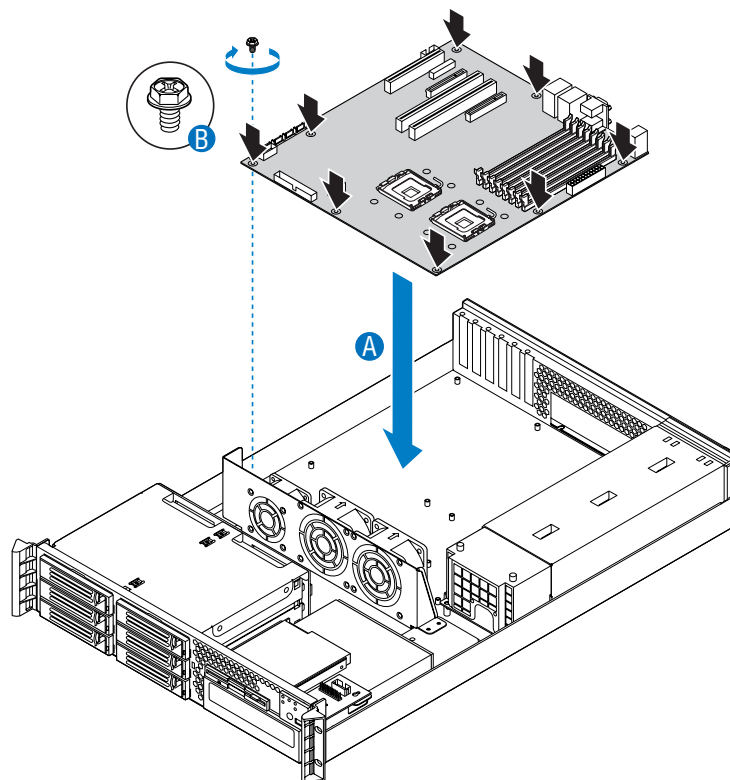

AF001469

**Figure 39. Installing the Server Board**



7. Install the processor air duct. For instructions, see [“Installing the Processor Air Duct”](#).
8. Install the server system cover. For instructions, see [“Installing the System Cover”](#).
9. Plug all peripheral devices and the AC power cable(s) into the server.

## Removing the Server Board

1. Observe the safety and ESD precautions at the beginning of this book. See [“Safety Information”](#).
2. Power down the server and unplug all peripheral devices and the AC power cable(s).
3. Remove the server system cover. For instructions, see [“Removing the System Cover”](#).
4. Remove the processor air duct. For instructions, see [“Removing the Processor Air Duct”](#).
5. Remove the eight screws from the server board (see letter “A”) and lift the server board from the server system (see letter “B”).

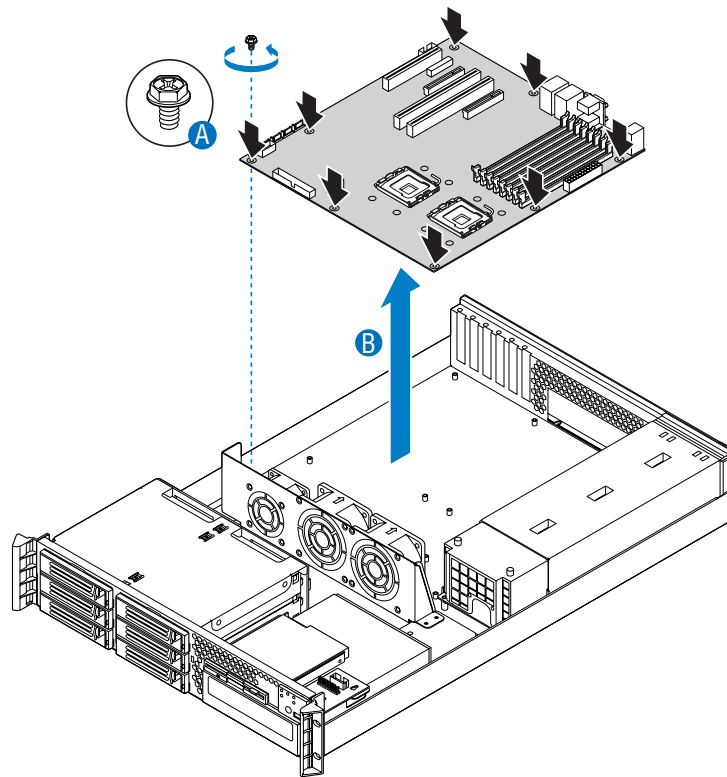

AF001468

**Figure 40. Removing the Server Board**

6. Install the replacement server board. For instructions, see “[Installing the Server Board](#)”.
7. Install the processor air duct. For instructions, see “[Installing the Processor Air Duct](#)”.
8. Install the server system cover. For instructions, see “[Installing the System Cover](#)”.
9. Plug all peripheral devices and the AC power cable(s) into the server.

## Replacing the Backup Battery

The lithium battery on the server board powers the RTC for up to 10 years in the absence of power. When the battery starts to weaken, it loses voltage, and the server settings stored in CMOS RAM in the RTC (for example, the date and time) may be wrong. Contact your customer service representative or dealer for a list of approved devices.

**Warning:** *Danger of explosion if battery is incorrectly replaced. Replace only with the same or equivalent type recommended by the equipment manufacturer. Discard used batteries according to manufacturer's instructions.*

**Advarsel:** Lithiumbatteri - Eksplosionsfare ved fejlagtig håndtering. Udskiftning må kun ske med batteri af samme fabrikat og type. Levér det brugte batteri tilbage til leverandøren.

**Advarsel:** Lithiumbatteri - Eksplosjonsfare. Ved utskifting benyttes kun batteri som anbefalt av apparatfabrikanten. Brukt batteri returneres apparatleverandøren.

**Varning:** Explosionsfara vid felaktigt batteribyte. Använd samma batterityp eller en ekvivalent typ som rekommenderas av apparattillverkaren. Kassera använt batteri enligt fabrikantens instruktion.

**Varoitus:** Paristo voi räjähtää, jos se on virheellisesti asennettu. Vaihda paristo ainoastaan laitevalmistajan suosittelemaan tyyppiin. Hävitä käytetty paristo valmistajan ohjeiden mukaisesti.

1. Observe the safety and ESD precautions in “[Safety Information](#)”.
2. Turn off all peripheral devices connected to the server. Turn off the server.
3. Disconnect the AC power cord(s) from the server.
4. Remove the server's cover and locate the battery. See the documentation that came with your server chassis for instructions on removing the server's cover.
5. Insert the tip of a small flat bladed screwdriver, or an equivalent, under the tab in the plastic retainer. Gently push down on the screwdriver to lift the battery.
6. Remove the battery from its socket.

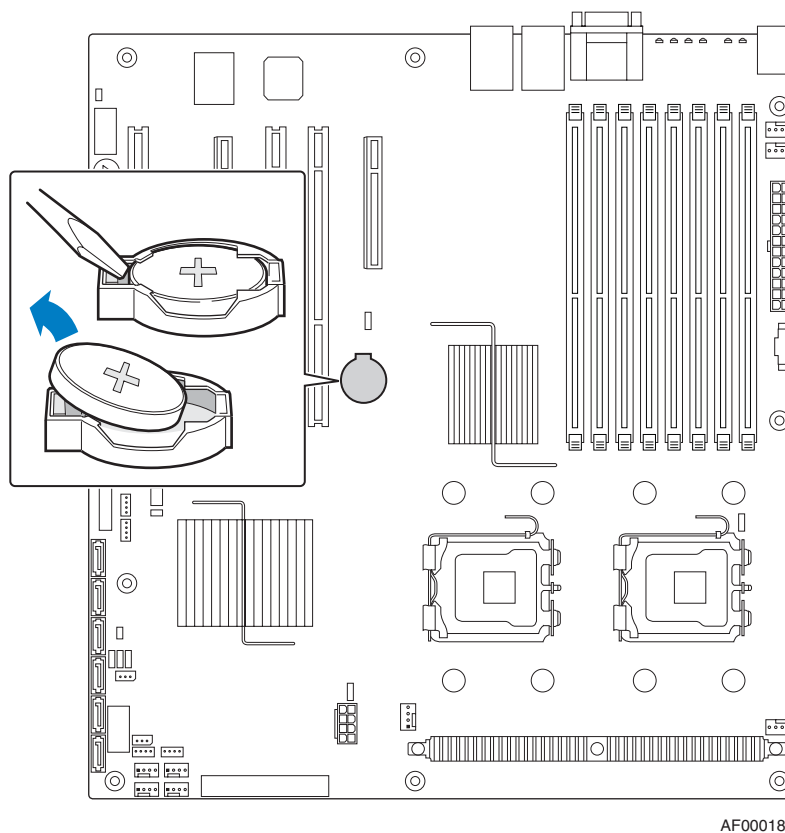

**Figure 41. Replacing the Backup Battery**

7. Dispose of the battery according to local ordinance.
8. Remove the new lithium battery from its package, and, being careful to observe the correct polarity, insert it in the battery socket.
9. Close the chassis.
10. Run Setup to restore the configuration settings to the RTC.

# Replacing the Redundant Power Supply (SR2520SAX/SR2520SAXS and SR2520SAXR/ SR2520SAXSR)

**Caution:** The power supply is not hot-swappable. Before removing or replacing the power supply, you must first take the server out of service, turn off all peripheral devices connected to the system, turn off the system by pressing the power button, and unplug the AC power cord from the system or wall outlet.

The power supply can be replaced if it fails or if one of the fans that is integrated into it fails. To replace the power supply, use the following instructions.

1. Observe the safety and ESD precautions at the beginning of this book. See “[Safety Information](#)”.
2. Power down the server and unplug all peripheral devices and the AC power cable(s).
3. Remove the server system cover. For instructions, see “[Removing the System Cover](#)”.
4. Press the green release latch to disengage the power supply (see letter “A”) and remove the power supply by sliding it out of the system (see letter “B”) as shown in the figure below.

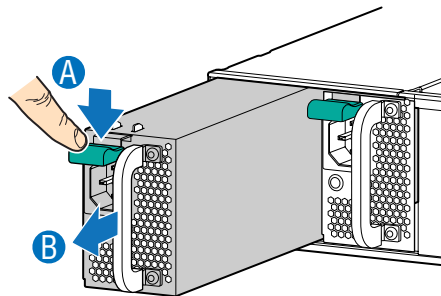

AF001455

**Figure 42. Removing Power Supply Module from the Server System  
(SR2520SAX/SR2520SAXS and SR2520SAXR/SR2520SAXSR)**

5. Insert the replacement power supply module into the power supply cage until it clicks into place.

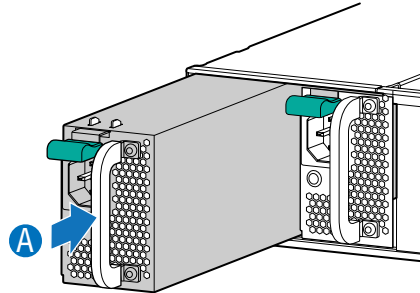

AF001456

**Figure 43. Installing Power Supply Module into the Server System (SR2520SAX/SR2520SAXS and SR2520SAXR/SR2520SAXSR)**

6. Install the server system cover. For instructions, see “[Installing the System Cover](#)”.
7. Plug all peripheral devices and the AC power cable(s) into the server.

## Replacing the Fixed Power Supply (SR2520SAF/SR2520SAFR)

**Caution:** *The power supply is not hot-swappable. Before removing or replacing the power supply, you must first take the server out of service, turn off all peripheral devices connected to the system, turn off the system by pressing the power button, and unplug the AC power cord from the system or wall outlet.*

The power supply can be replaced if it fails or if one of the fans that is integrated into it fails. To replace the power supply, use the following instructions.

1. Observe the safety and ESD precautions at the beginning of this book. See “[Safety Information](#)”.
2. Power down the server and unplug all peripheral devices and the AC power cable (see letter “A” in the figure below).
3. Remove the server system cover. For instructions, see “[Removing the System Cover](#)”.
4. Remove the power supply bracket by removing the two screws holding it in place (see letter “B” in the figure below).
5. Lift up slightly to disengage the power supply from the chassis tab (see letter “C” in the figure below).
6. Slide the power supply forward to disengage the back panel and lift it straight up to remove (see letter “D” in the figure below).

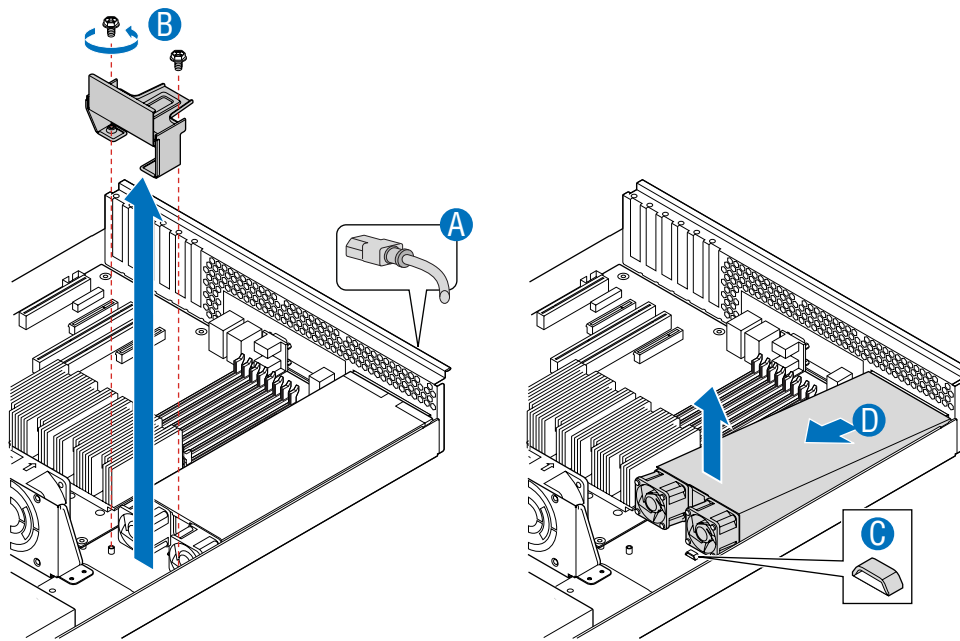

AF001667

**Figure 44. Removing Power Supply Module from the Server System (SR2520SAF/SR2520SAFR)**

7. Slide the replacement power supply into the chassis (see letter “A” in the figure below).
8. Make sure the power supply is seated behind the chassis tab (see letter “B” in the figure below).
9. Install the power supply bracket using the two screws you removed in step 4 (see letter “C” in the figure below).

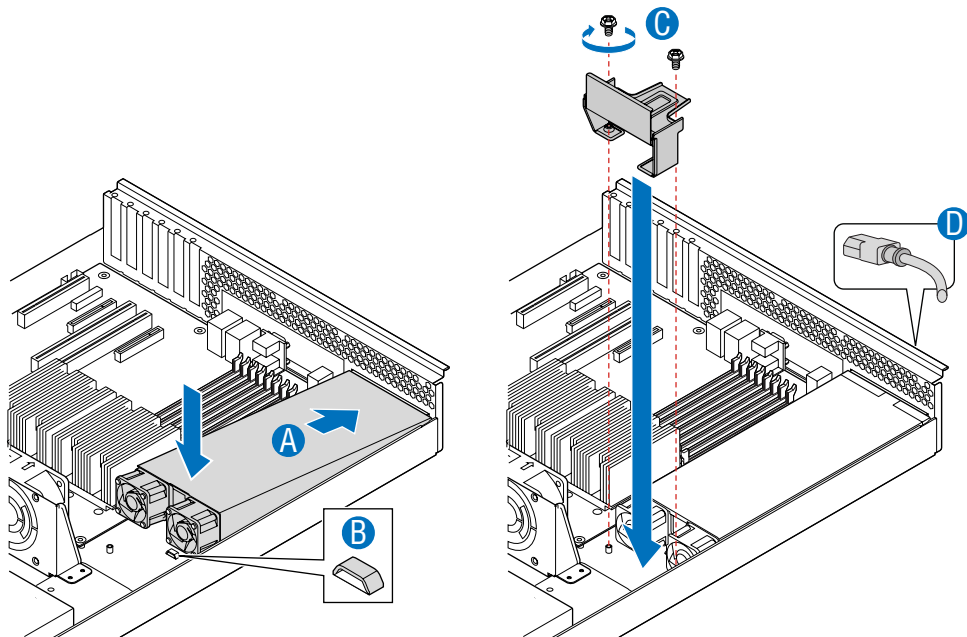

AF001668

**Figure 45. Installing Power Supply Module into the Server System (SR2520SAF/SR2520SAFR)**

10. Install the server system cover. For instructions, see “[Installing the System Cover](#)”.
11. Plug all peripheral devices and the AC power cable(s) into the server (see letter “D” in the figure above).

## Replacing the Front Panel Board

Your server must be operated with a front panel board installed.

**Caution:** *The front panel board is NOT hot swappable. Before removing or replacing the front panel board, you must first take the server out of service, turn off all peripheral devices connected to the system, turn off the system by pressing the power button, and unplug the AC power cord from the system or wall outlet.*

1. Observe the safety and ESD precautions at the beginning of this book. See “[Safety Information](#)”.
2. Power down the server and unplug all peripheral devices and the AC power cable(s).
3. Remove the front bezel if it is installed. For instructions, see “[Removing the Front Bezel](#)”.

4. Remove the server system cover. For instructions, see [“Removing the System Cover”](#).
5. Remove the screw holding the front panel board in place (see letter “A” in the figure below).
6. Slide the front panel board back (see letter “B” in the figure below) and lift up to remove it from the server system (see letter “C” in the figure below).

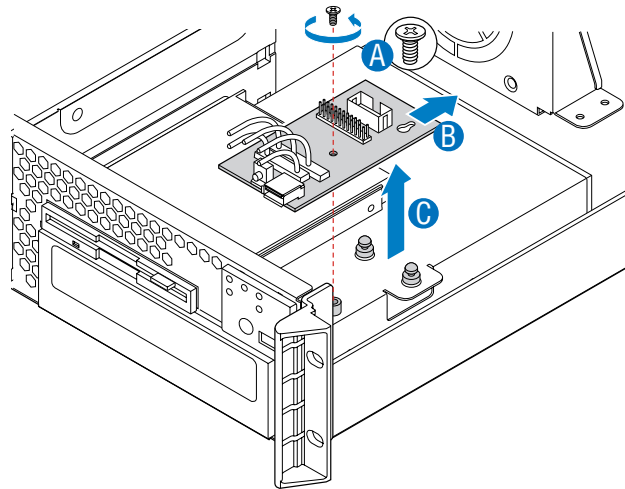

AF001460

**Figure 46. Removing the Front Panel Board**

7. Remove the light pipes from the front panel board you just removed (see letters “A” and “B” in the figure below). These will be used in the replacement front panel board.

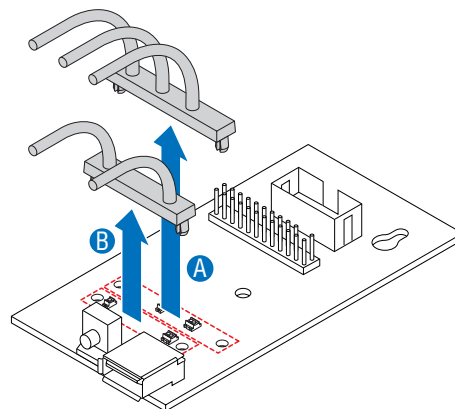

AF001660

**Figure 47. Removing the Light Pipes from the Front Panel Board**



8. Lower the replacement front panel board into the server system (see letter “A”) and slide it forward (see letter “B”) until it clicks into place.
9. Secure the front panel board in place with a screw (see letter “C”).

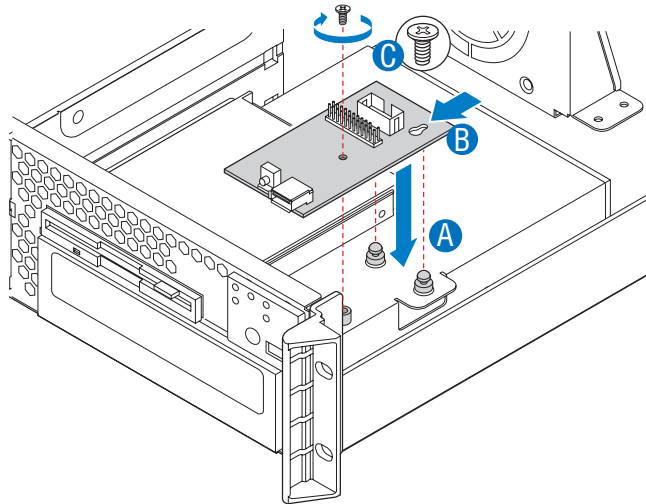

AF001461

**Figure 48. Installing Front Panel Board into the Server System**

10. Install the light pipes into the replacement front panel board starting with the outer edge first (see letters “A” and “B” in the figure below).

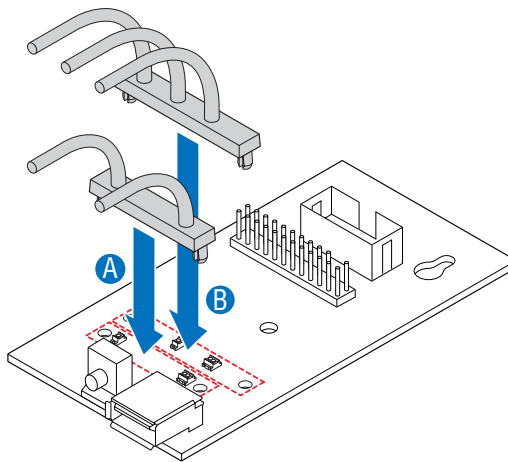

AF001661

**Figure 49. Installing Light Pipes onto the Front Panel Board**

11. Install the server system cover. For instructions, see [“Installing the System Cover”](#).
12. (Optional) Install the front bezel. For instructions, see [“Installing the Front Bezel”](#).
13. Plug all peripheral devices and the AC power cable(s) into the server.

# Replacing a System Fan

**Caution:** The system fans are NOT hot swappable. Before removing or replacing a fan, you must first take the server out of service, turn off all peripheral devices connected to the system, turn off the system by pressing the power button, and unplug the AC power cord from the system or wall outlet.

**Note:** The fans that are integrated into the power supply cannot be replaced separately. If one of the fans in the power supply fails, the power supply must be replaced.

The system fans at the front of the Intel® Server System SR2520SA can be individually replaced if one of them fails. Use the steps below to replace either a dual rotor fan or a single rotor fan.

1. Observe the safety and ESD precautions at the beginning of this book. See “[Safety Information](#)”.
2. Power down the server and unplug all peripheral devices and the AC power cable(s).
3. Remove the server system cover. For instructions, see “[Removing the System Cover](#)”.
4. Disconnect the fan cables from the server board (see letter “A” in the figure below).
5. Remove the four screws securing the fan module to the chassis (see letter “B” in the figure below). Lift straight up to remove the module (see letter “C” in the figure below).

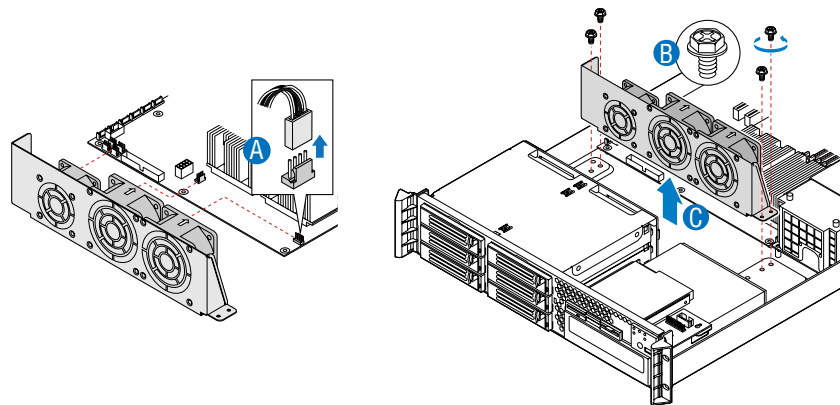

AF001462

**Figure 50. Removing the Fan Module**

6. Remove the two screws from the fan module and remove the failed fan from the module.

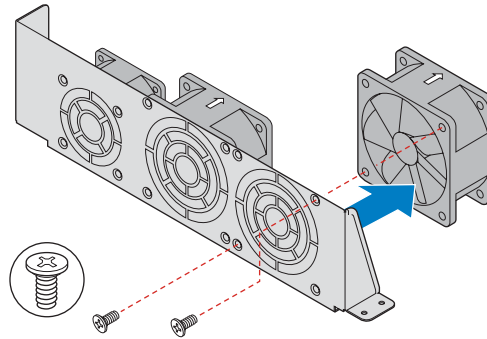

AF001463

**Figure 51. Removing a Fan from the Fan Module**

7. Position the replacement fan so the connector on the fan is at the right and pointing down.
8. With the fan oriented correctly, insert the fan into the fan module, and secure the fan with two screws as shown.

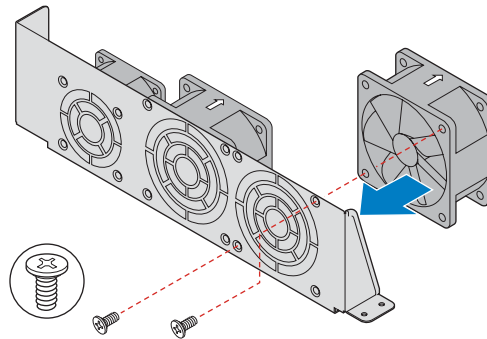

AF001464

**Figure 52. Installing a Fan into the Fan Module**

9. Lower the fan module into the server system (see letter “A” in the figure below) and secure the module with four screws as shown (see letter “B”).
10. Connect the fan cables to the server board (see letter “C” in the figure below).

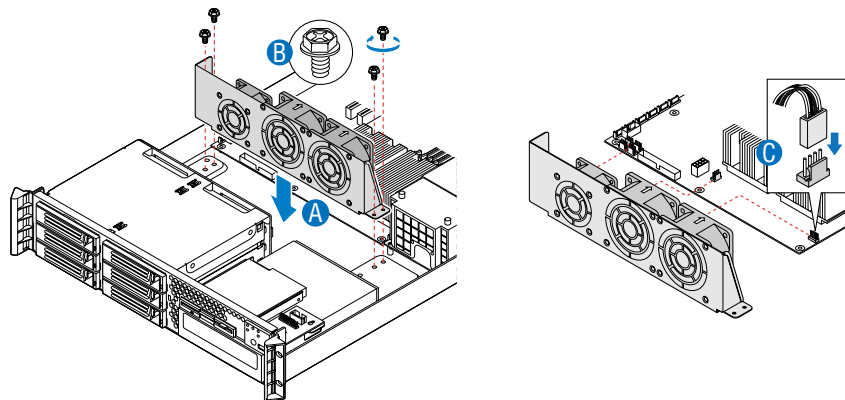

AF001465

**Figure 53. Installing the Fan Module**

11. Install the server system cover. For instructions, see [“Installing the System Cover”](#).
12. Plug all peripheral devices and the AC power cable(s) into the server.

## Installing and Removing the Rack Handles

### Installing the Rack Handles

1. Observe the safety and ESD precautions at the beginning of this book. See [“Safety Information”](#).
2. Power down the server and unplug all peripheral devices and the AC power cable(s).
3. Align the rack handle with the two holes on the side of the server system as shown in the figure below.
4. Attach the rack handle to the server system with two screws as shown in the figure below.

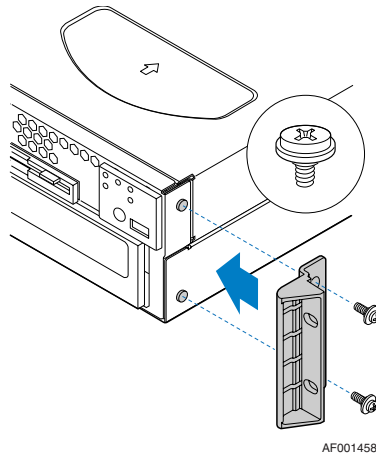
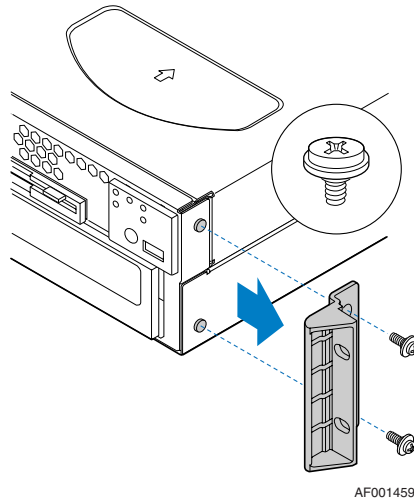

**Figure 54. Installing the Rack Handle**

5. Install the front bezel. For instructions, see [“Installing the Front Bezel”](#).
6. Plug all peripheral devices and the AC power cable(s) into the server.

## Removing the Rack Handles

1. Observe the safety and ESD precautions at the beginning of this book. See [“Safety Information”](#).
2. Power down the server and unplug all peripheral devices and the AC power cable(s).
3. Remove the front bezel if it is installed. For instructions, see [“Removing the Front Bezel”](#).
4. Remove the two screws holding the rack handle in place, and remove the rack handle from the server system as shown in the figure below.



**Figure 55. Removing the Rack Handle**

5. Plug all peripheral devices and the AC power cable(s) into the server.

# 4 Server Utilities

---

## Using the BIOS Setup Utility

This section describes the BIOS Setup Utility options, which is used to change server configuration defaults. You can run BIOS Setup with or without an operating system being present. See [“Server System References”](#) for a link to the Intel® 5000 Series Chipsets Server Board Family Datasheet where you will find details about specific BIOS setup screens.

### Starting Setup

You can enter and start BIOS Setup under several conditions:

- When you turn on the server, after POST completes the memory test.
- When you have moved the CMOS jumper on the server board to the "Clear CMOS" position (enabled).

In the two conditions listed above, during the Power On Self Test (POST), you will see this prompt:

```
Press <F2> to enter SETUP
```

In a third condition, when CMOS/NVRAM has been corrupted, you will see other prompts but not the <F2> prompt:

```
Warning: CMOS checksum invalid  
Warning: CMOS time and date not set
```

In this condition, the BIOS will load default values for CMOS and attempt to boot.

### If You Cannot Access Setup

If you are not able to access BIOS Setup, you might need to clear the CMOS memory. For instructions on clearing the CMOS, see ["Clearing the CMOS"](#).

### Setup Menus

Each BIOS Setup menu page contains a number of features. Except for those features that are provided only to display automatically configured information, each feature is associated with a value field that contains user-selectable parameters. These parameters can be changed if the user has adequate security rights. If a value cannot be changed for any reason, the feature's value field is inaccessible.

“Setup Menu Key Use” describes the keyboard commands you can use in the BIOS Setup menus.

**Table 4. Setup Menu Key Use**

Key to Press	Description
<F1>	Pressing <F1> on any menu invokes the general help window.
Left and right arrows	The left and right arrow keys are used to move between the major menu pages. The keys have no affect if a submenu or pick list is displayed.
Up arrow	Select Item up - The up arrow is used to select the previous value in a menu item's option list, or a value field pick list. Pressing the <Enter> key activates the selected item.
Down arrow	Select Item down - The down arrow is used to select the next value in a menu item's option list, or a value field pick list. Pressing the <Enter> key activates the selected item.
<F5> or <->	Change Value - The minus key or the <F5> function key is used to change the value of the current item to the previous value. This key scrolls through the values in the associated pick list without displaying the full list.
<F6> or <+>	Change Value - The plus key or the <F6> function key is used to change the value of the current menu item to the next value. This key scrolls through the values in the associated pick list without displaying the full list. On 106-key Japanese keyboards, the plus key has a different scan code than the plus key on the other keyboard, but it has the same effect.
<Enter>	Execute Command - The <Enter> key is used to activate submenus when the selected feature is a submenu, or to display a pick list if a selected feature has a value field, or to select a sub-field for multi-valued features like time and date. If a pick list is displayed, the <Enter> key will undo the pick list, and allow another selection in the parent menu.
<Esc>	Exit - The <Esc> key provides a mechanism for backing out of any field. This key will undo the pressing of the <Enter> key. When the <Esc> key is pressed while editing any field or selecting features of a menu, the parent menu is re-entered. When the <Esc> key is pressed in any submenu, the parent menu is re-entered. When the <Esc> key is pressed in any major menu, the exit confirmation window is displayed and the user is asked whether changes can be discarded.
<F9>	Setup Defaults - Pressing <F9> causes the following to appear: <pre style="margin-left: 40px;">           Setup Confirmation           Load default configuration now?           [Yes] [No]           </pre> If "Yes" is selected and the <Enter> key is pressed, all Setup fields are set to their default values. If "No" is selected and the <Enter> key is pressed, or if the <Esc> key is pressed, the user is returned to where they were before <F9> was pressed without affecting any existing field values.



**Table 4. Setup Menu Key Use**

Key to Press	Description
<F10>	<p>Save and Exit - Pressing &lt;F10&gt; causes the following message to appear:</p> <pre>                Setup Confirmation                 Save Configuration changes and exit now?                 [Yes] [No]</pre> <p>If "Yes" is selected and the &lt;Enter&gt; key is pressed, all changes are saved and Setup is exited. If "No" is selected and the &lt;Enter&gt; key is pressed, or the &lt;Esc&gt; key is pressed, the user is returned to where they were before &lt;F10&gt; was pressed without affecting any existing values.</p>

## Upgrading the BIOS

The upgrade utility allows you to upgrade the BIOS in flash memory. The code and data in the upgrade file include the following:

- On-board system BIOS, including the recovery code, BIOS Setup Utility, and strings.
- On-board video BIOS, and other option ROMs for devices embedded on the server board.
- OEM binary area
- Microcode
- A way to change the BIOS language

## Preparing for the Upgrade

The steps below explain how to prepare to upgrade the BIOS, including how to record the current BIOS settings and how to obtain the upgrade utility.

**Note:** *In the unlikely event that a BIOS error occurs during the BIOS update process, a recovery process may need to be followed to return the system to service. See “[Server System References](#)” for a link to necessary software and instructions.*

## Recording the Current BIOS Settings

1. Boot the computer and press <F2> when you see the message:  
Press <F2> Key if you want to run SETUP
2. Write down the current settings in the BIOS Setup program.

**Note:** *Do not skip step 2. You will need these settings to configure your server at the end of the procedure.*

## Obtaining the Upgrade

Download the BIOS image file to a temporary folder on your hard drive. See “[Server System References](#)” for a link to the update software.

**Note:** Review the instructions and release notes that are provided in the readme file distributed with the BIOS image file before attempting a BIOS upgrade. The release notes contain critical information regarding jumper settings, specific fixes, or other information to complete the upgrade.

## Upgrading the BIOS

Follow the instructions in the readme file that came with the BIOS upgrade. When the update completes, remove the bootable media from which you performed the upgrade.

**Caution:** Do not power down the system during the BIOS update process! The system will reset automatically when the BIOS update process is completed.

**Note:** You may encounter a CMOS Checksum error or other problem after reboot. If this happens, shut down the system and boot it again. CMOS checksum errors require that you enter Setup, check your settings, save your settings, and exit Setup.

## Clearing the Password

If the user or administrator password(s) is lost or forgotten, moving the password clear jumper into the "clear" position clears both passwords. The password clear jumper must be restored to its original position before a new password(s) can be set.

1. Power down the system and disconnect the AC power.
2. Open the server chassis.
3. Move the jumper from the normal operation position, Password Clear Protect, at pins 1 and 2 to the Password Clear Erase position, covering pins 2 and 3.

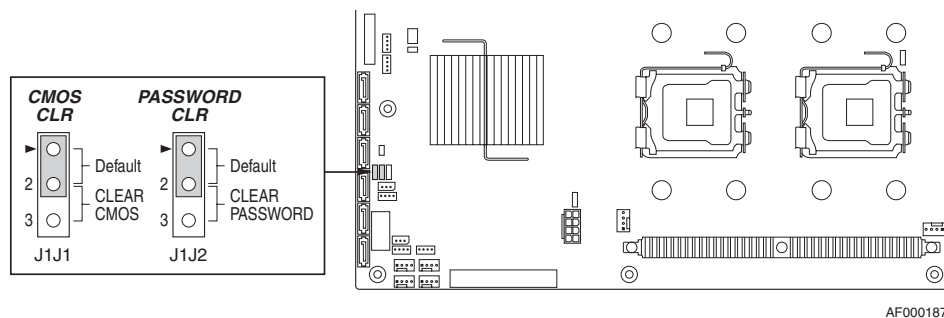

**Figure 56. Clear Password Jumper**

4. Wait five seconds.
5. Return the Password Clear jumper to the Password Clear Protect position, covering pins 1 and 2.
6. Close the server chassis.
7. Reconnect the AC power and power up the server.
8. The password is now cleared and can be reset by going into BIOS setup.

## Clearing the CMOS

If you are not able to access the BIOS setup screens, the CMOS Clear jumper will need to be used to reset the configuration RAM.

1. Power down the system and disconnect the AC power.
2. Open the server.
3. Move the jumper from the normal operation position, CMOS Clear by BMC, at pins 1 and 2 to the CMOS Clear Force Erase position, covering pins 2 and 3.

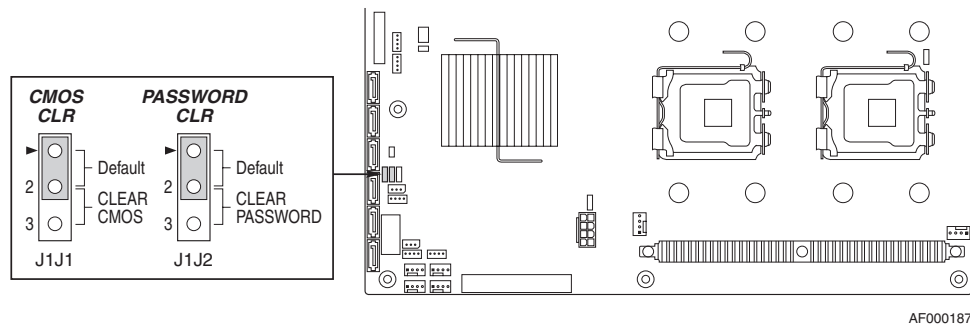

**Figure 57. Clear CMOS Jumper**

4. Wait five seconds.
5. Return the CMOS Clear jumper to the CMOS Clear by BMC location, covering pins 1 and 2.
6. Close the server chassis.
7. Reconnect the AC power and power up the system.
8. The CMOS is now cleared and can be reset by going into the BIOS setup.



# Appendix A: Technical Reference

## Cable Routing (SR2520SAX/SR2520SAXS and SR2520SAXR/SR2520SAXSR)

When you add or remove components from your server system, make sure your cables are routed correctly before reinstalling the server system cover. Use caution to make sure no cables or wires are pinched and that the airflow from the fans is not blocked. Use the figures below to determine the correct cable routing.



AF001457

**Figure 58. Cable Routing (SR2520SAX/SR2520SAXS and SR2520SAXR/SR2520SAXSR)**

## Cable Routing (SR2520SAF/SR2520SAFR)

When you add or remove components from your server system, make sure your cables are routed correctly before reinstalling the server system cover. Use caution to make sure no cables or wires are pinched and that the airflow from the fans is not blocked. Use the figures below to determine the correct cable routing.

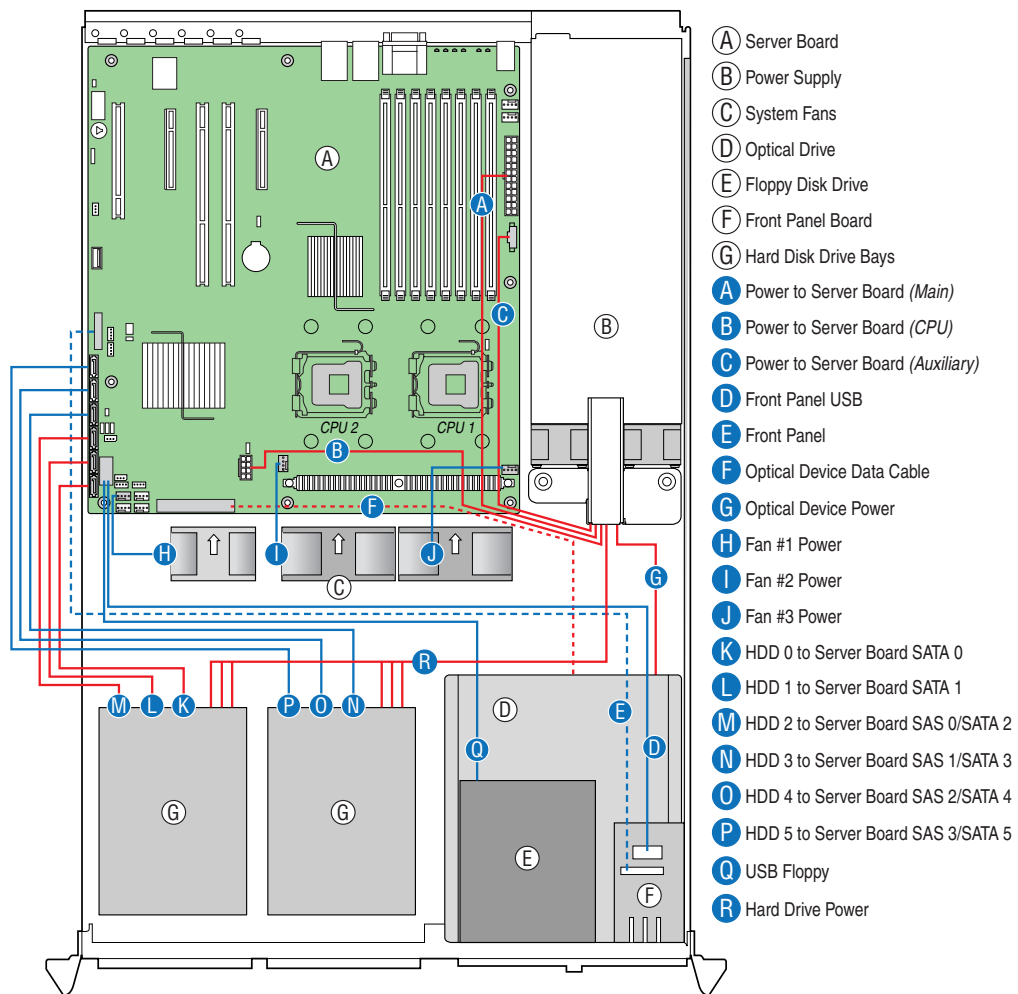

AF001664

**Figure 59. Cable Routing (SR2520SAF/SR2520SAFR)**

## 600W Single Power Supply Input Voltages

- 100-127V at 50/60 Hz; 8.55 A max.
- 200-240V at 50/60 Hz; 4.3 A max.

## 600W Single Power Supply Output Voltages

The table below lists the total wattage available from the power subsystem for each voltage. Ensure that your loads do not exceed the combined total wattage of 600 Watts. For information about calculating the power usage for your configuration, see "Calculating Power Usage."

**Table 5. Power Supply Output Capability**

Voltage	Maximum Current
+3.3 V	15 A
+5.0 V	30 A
+5 V Standby	6.0 A
+12.0	20 A
-12.0 V	2.0 A

**Warning:** Do not exceed a combined power output of 90 Watts for the +5 V and +3.3 V outputs. Exceeding a combined 90 Watts will overload the power subsystem and may cause the power supplies to overheat and malfunction.

# System Environmental Specifications

**Table 6. System Environmental Specifications**

Temperature	
Non-operating	-40 ° to 70 °C.
Operating	10 ° to 35 °C; derated 0.5 °C for every 1000 ft (305 m) to a maximum of 10,000 ft.
Humidity	
Non-operating	90% relative humidity (non-condensing) at 30 °C.
Shock	
Operating	2.0 g, 11 msec, 1/2 sine
Packaged	Operational after an 18" free fall.
Acoustic noise	7 Bels in sound power for a typical office ambient temperature (65-75 °F). Your selection of peripherals may change the noise level.
Electrostatic discharge (ESD)	Tested to 15 kilovolts (kV); no component damage.



# Appendix B: LED Decoder (SR2520SAX /SR2520SAXS and SR2520SAXR/ SR2520SAXSR Only)

---

During the system boot process, BIOS executes a number of platform configuration processes, each of which is assigned a specific hex POST code number. As each configuration routine is started, BIOS will display the given POST code to the POST Code Diagnostic LEDs found on the back edge of the server board. To assist in troubleshooting a system hang during the POST process, the Diagnostic LEDs can be used to identify the last POST process to be executed.

Each POST code will be represented by a combination of colors from the four LEDs. The LEDs are capable of displaying three colors: green, red, and amber. The POST codes are divided into two nibbles, an upper nibble and a lower nibble. Each bit in the upper nibble is represented by a red LED and each bit in the lower nibble is represented by a green LED. If both bits are set in the upper and lower nibbles then both red and green LEDs are lit, resulting in an amber color. If both bits are clear, then the LED is off.

In the below example, BIOS sends a value of ACh to the diagnostic LED decoder. The LEDs are decoded as follows:

- red bits = 1010b = Ah
- green bits = 1100b = Ch

Since the red bits correspond to the upper nibble and the green bits correspond to the lower nibble, the two are concatenated to be ACh.

**Table 7. POST Progress Code LED Example**

	8h		4h		2h		1h	
LEDs	Red	Green	Red	Green	Red	Green	Red	Green
ACh	1	1	0	1	1	0	0	0
Result	Amber		Green		Red		Off	
	MSB				LSB			

**Table 8. Diagnostic LED POST Code Decoder**

Checkpoint	Diagnostic LED Decoder				Description
	G=Green, R=Red, A=Amber				
	MSB			LSB	
<b>Host Processor</b>					
0x10h	OFF	OFF	OFF	R	Power-on initialization of the host processor (bootstrap processor)
0x11h	OFF	OFF	OFF	A	Host processor cache initialization (including AP)
0x12h	OFF	OFF	G	R	Starting application processor initialization
0x13h	OFF	OFF	G	A	SMM initialization
<b>Chipset</b>					
0x21h	OFF	OFF	R	G	Initializing a chipset component
<b>Memory</b>					
0x22h	OFF	OFF	A	OFF	Reading configuration data from memory (SPD on DIMM)
0x23h	OFF	OFF	A	G	Detecting presence of memory
0x24h	OFF	G	R	OFF	Programming timing parameters in the memory controller
0x25h	OFF	G	R	G	Configuring memory parameters in the memory controller
0x26h	OFF	G	A	OFF	Optimizing memory controller settings
0x27h	OFF	G	A	G	Initializing memory, such as ECC init
0x28h	G	OFF	R	OFF	Testing memory

**Table 8. Diagnostic LED POST Code Decoder**

<b>PCI Bus</b>					
0x50h	OFF	R	OFF	R	Enumerating PCI busses
0x51h	OFF	R	OFF	A	Allocating resources to PCI busses
0x52h	OFF	R	G	R	Hot Plug PCI controller initialization
0x53h	OFF	R	G	A	Reserved for PCI bus
0x54h	OFF	A	OFF	R	Reserved for PCI bus
0x55h	OFF	A	OFF	A	Reserved for PCI bus
0x56h	OFF	A	G	R	Reserved for PCI bus
0x57h	OFF	A	G	A	Reserved for PCI bus
<b>USB</b>					
0x58h	G	R	OFF	R	Resetting USB bus
0x59h	G	R	OFF	A	Reserved for USB devices
<b>ATA / ATAPI / SATA</b>					
0x5Ah	G	R	G	R	Resetting PATA / SATA bus and all devices
0x5Bh	G	R	G	A	Reserved for ATA
<b>SMBUS</b>					
0x5Ch	G	A	OFF	R	Resetting SMBUS
0x5Dh	G	A	OFF	A	Reserved for SMBUS
<b>Local Console</b>					
0x70h	OFF	R	R	R	Resetting the video controller (VGA)
0x71h	OFF	R	R	A	Disabling the video controller (VGA)
0x72h	OFF	R	A	R	Enabling the video controller (VGA)
<b>Remote Console</b>					
0x78h	G	R	R	R	Resetting the console controller
0x79h	G	R	R	A	Disabling the console controller
0x7Ah	G	R	A	R	Enabling the console controller
<b>Keyboard (PS2 or USB)</b>					
0x90h	R	OFF	OFF	R	Resetting the keyboard
0x91h	R	OFF	OFF	A	Disabling the keyboard
0x92h	R	OFF	G	R	Detecting the presence of the keyboard

**Table 8. Diagnostic LED POST Code Decoder**

0x93h	R	OFF	G	A	Enabling the keyboard
0x94h	R	G	OFF	R	Clearing keyboard input buffer
0x95h	R	G	OFF	A	Instructing keyboard controller to run Self Test (PS2 only)
<b>Mouse (PS2 or USB)</b>					
0x98h	A	OFF	OFF	R	Resetting the mouse
0x99h	A	OFF	OFF	A	Detecting the mouse
0x9Ah	A	OFF	G	R	Detecting the presence of mouse
0x9Bh	A	OFF	G	A	Enabling the mouse
<b>Fixed Media</b>					
0xB0h	R	OFF	R	R	Resetting fixed media device
0xB1h	R	OFF	R	A	Disabling fixed media device
0xB2h	R	OFF	A	R	Detecting presence of a fixed media device (IDE hard drive detection, etc.)
0xB3h	R	OFF	A	A	Enabling / configuring a fixed media device
<b>Removable Media</b>					
0xB8h	A	OFF	R	R	Resetting removable media device
0xB9h	A	OFF	R	A	Disabling removable media device
0xBAh	A	OFF	A	R	Detecting presence of a removable media device (IDE CDROM detection, etc.)
0xBCh	A	G	R	R	Enabling / configuring a removable media device
<b>Boot Device Selection</b>					
0xD0	R	R	OFF	R	Trying boot device selection
0xD1	R	R	OFF	A	Trying boot device selection
0xD2	R	R	G	R	Trying boot device selection
0xD3	R	R	G	A	Trying boot device selection
0xD4	R	A	OFF	R	Trying boot device selection
0xD5	R	A	OFF	A	Trying boot device selection
0xD6	R	A	G	R	Trying boot device selection
0xD7	R	A	G	A	Trying boot device selection
0xD8	A	R	OFF	R	Trying boot device selection
0xD9	A	R	OFF	A	Trying boot device selection

**Table 8. Diagnostic LED POST Code Decoder**

0XDA	A	R	G	R	Trying boot device selection
0xDB	A	R	G	A	Trying boot device selection
0xDC	A	A	OFF	R	Trying boot device selection
0xDE	A	A	G	R	Trying boot device selection
0xDF	A	A	G	A	Trying boot device selection
<b>Pre-EFI Initialization (PEI) Core</b>					
0xE0h	R	R	R	OFF	Started dispatching early initialization modules (PEIM)
0xE2h	R	R	A	OFF	Initial memory found, configured, and installed correctly
0xE1h	R	R	R	G	Reserved for initialization module use (PEIM)
0xE3h	R	R	A	G	Reserved for initialization module use (PEIM)
<b>Driver Execution Environment (DXE) Core</b>					
0xE4h	R	A	R	OFF	Entered EFI driver execution phase (DXE)
0xE5h	R	A	R	G	Started dispatching drivers
0xE6h	R	A	A	OFF	Started connecting drivers
<b>DXE Drivers</b>					
0xE7h	R	A	A	G	Waiting for user input
0xE8h	A	R	R	OFF	Checking password
0xE9h	A	R	R	G	Entering BIOS setup
0xEAh	A	R	A	OFF	Flash Update
0xEEh	A	A	A	OFF	Calling Int 19. One beep unless silent boot is enabled.
0xEFh	A	A	A	G	Unrecoverable boot failure / S3 resume failure
<b>Runtime Phase / EFI Operating System Boot</b>					
0xF4h	R	A	R	R	Entering Sleep state
0xF5h	R	A	R	A	Exiting Sleep state
0xF8h	A	R	R	R	Operating system has requested EFI to close boot services (ExitBootServices ( ) has been called)
0xF9h	A	R	R	A	Operating system has switched to virtual address mode (SetVirtualAddressMap ( ) has been called)

**Table 8. Diagnostic LED POST Code Decoder**

0xFAh	A	R	A	R	Operating system has requested the system to reset (ResetSystem () has been called)
<b>Pre-EFI Initialization Module (PEIM) / Recovery</b>					
0x30h	OFF	OFF	R	R	Crisis recovery has been initiated because of a user request
0x31h	OFF	OFF	R	A	Crisis recovery has been initiated by software (corrupt flash)
0x34h	OFF	G	R	R	Loading crisis recovery capsule
0x35h	OFF	G	R	A	Handing off control to the crisis recovery capsule
0x3Fh	G	G	A	A	Unable to complete crisis recovery.

# Appendix C: Getting Help

---

## World Wide Web

<http://support.intel.com/support/motherboards/server/s5000vsa>.

## Telephone

All calls are billed per incident, levied in local currency at the applicable credit card exchange rate plus applicable taxes. (Intel reserves the right to change the pricing for telephone support at any time without notice).

Before calling, fill out an Intel Server Issue Report Form. A form is provided on the Internet. For the fastest service, please submit your form via the Internet.

For an updated support contact list, see <http://www.intel.com/support/9089.htm/>

## U.S. and Canada

916-377-7000

## Europe

**Belgium** ..... 02 714 3182

**Denmark** ... 38 487077

**Finland** ..... 9 693 79297

**France**..... 01 41 918529

**Germany** ... 069 9509 6099

**Holland** ..... 020 487 4562

**Italy**..... 02 696 33276

**Norway** ..... 23 1620 50

**Spain**..... 91 377 8166

**Sweden**..... 08 445 1251

**UK**..... 870 6072439

## In Asia-Pacific region

**Australia**.... 1800 649931

**Cambodia**.. 63 2 636 9797 (via Philippines)

**China** ..... 800 820 1100 (toll-free)  
..... 8 621 33104691 (not toll-free)

**Hong Kong** 852 2 844 4456

**India**..... 0006517 2 68303634 (manual toll-free. You need an IDD-equipped telephone)

**Indonesia** ... 803 65 7249

**Korea** ..... 822 767 2595

**Malaysia** .... 1 800 80 1390

**Myanmar**... 63 2 636 9796 (via Philippines)

**New Zealand** 0800 444 365

**Pakistan**.... 632 63684 15 (IDD via Philippines)

**Philippines** 1 800 1 651 0117

**Singapore** .. 65 6213-1311

**Taiwan** ..... 2 2545-1640

**Thailand** .... 1 800 631 0003

**Vietnam** ..... 632 6368416 (IDD via Philippines)

## Japan

**Domestic**.... 0120 868686

**Outside country** 81 298 47 0800

## Latin America

**Argentina** .. Contact AT&T USA at 0-800 222 1288. Once connected, dial 800 843 4481

**Brazil** ..... 001-916 377 0180

**Chile**

**Easter Island.** ..... Contact AT&T USA at 800 800 311. Once connected, dial 800 843 4481

**Mainland and Juan** .. Contact AT&T USA at 800 225 288. Once connected, dial 800 843 4481



**Colombia**... Contact AT&T USA at 01 800 911 0010. Once connected, dial 800 843 4481

**Costa Rica** . Contact AT&T USA at 0 800 0 114 114. Once connected, dial 800 843 4481

**Ecuador**

**(Andimate)** .... Contact AT&T USA at 1 999 119. Once connected, dial 800 843 4481

**(Pacifictel)** ..... Contact AT&T USA at 1 800 225 528. Once connected, dial 800 843 4481

**Guatemala**. Contact AT&T USA at 99 99 190. Once connected, dial 800 843 4481

**Mexico** ..... Contact AT&T USA at 001 800 462 628 4240. Once connected, dial 800 843 4481

**Miami** ..... 1 800 621 8423

**Panama**..... Contact AT&T USA at 00 800 001 0109. Once connected, dial 800 843 4481

**Paraguay** ... 001 916 377 0114

**Peru** ..... 001 916 377 0114

**Uruguay**..... 001 916 377 0114

**Venezuela**... Contact AT&T USA at 0 800 2255 288. Once connected, dial 800 843 4481



# Appendix D: Regulatory and Compliance Information

---

## Product Regulatory Compliance

**Warning:** *To ensure regulatory compliance, you must adhere to the assembly instructions in this guide to ensure and maintain compliance with existing product certifications and approvals. Use only the described, regulated components specified in this guide. Use of other products/components will void the UL listing and other regulatory approvals of the product and will most likely result in noncompliance with product regulations in the region(s) in which the product is sold.*

*To help ensure EMC compliance with your local regional rules and regulations, before computer integration, make sure that the server system, power supply, and other modules have passed EMC testing using a server board with a microprocessor from the same family (or higher) and operating at the same (or higher) speed as the microprocessor used on this server board. The final configuration of your end system product may require additional EMC compliance testing. For more information, please contact your local Intel representative.*

*This is an FCC Class A device. Integration of it into a Class B system does not result in a Class B device.*

## Product Safety Compliance

This server system product, when correctly integrated per this guide, complies with the following safety and electromagnetic compatibility (EMC) regulations.

### Intended Application

This product was evaluated as Information Technology Equipment (ITE), which may be installed in offices, schools, computer rooms, and similar commercial type locations. The suitability of this product for other product categories and environments (such as: medical, industrial, telecommunications, NEBS, residential, alarm systems, test equipment, etc.), other than an ITE application, may require further evaluation.

## Product Safety Compliance

The server system complies with the following product safety requirements:

- UL60950 - CSA 60950 (USA / Canada)
- EN60950 (Europe)
- IEC60950 (International)

- CB Certificate & Report, IEC60950 (report to include all country national deviations)
- GS License (Germany)
- GOST R 50377-92 - License (Russia)
- Belarus License (Belarus)
- Ukraine License (Ukraine)
- CE - Low Voltage Directive 73/23/EEE (Europe)
- IRAM Certification (Argentina)

## Product EMC Compliance - Class A Compliance

This server system has been tested and verified to comply with the following electromagnetic compatibility (EMC) regulations when installed in a compatible Intel® host system. For information on compatible host system(s) refer to Intel's Server Builder Web site or contact your local Intel representative.

- FCC /ICES-003 - Emissions (USA/Canada) Verification
- CISPR 22 - Emissions (International)
- EN55022 - Emissions (Europe)
- EN55024 - Immunity (Europe)
- EN61000-3-2 - Harmonics (Europe)
- EN61000-3-3 - Voltage Flicker (Europe)
- CE - EMC Directive 89/336/EEC (Europe)
- VCCI Emissions (Japan)
- AS/NZS 3548 Emissions (Australia / New Zealand)
- BSMI CNS13438 Emissions (Taiwan)
- GOST R 29216-91 Emissions (Russia)
- GOST R 50628-95 Immunity (Russia)
- Belarus License (Belarus)
- Ukraine License (Ukraine)
- RRL MIC Notice No. 1997-41 (EMC) & 1997-42 (EMI) (Korea)





## Certifications / Registrations / Declarations

- UL Certification (US/Canada)
- CE Declaration of Conformity (CENELEC Europe)
- FCC/ICES-003 Class A Attestation (USA/Canada)
- VCCI Certification (Japan)
- C-Tick Declaration of Conformity (Australia)
- MED Declaration of Conformity (New Zealand)
- BSMI Certification (Taiwan)
- GOST R Certification / License (Russia)
- Belarus Certification / License (Belarus)
- RRL Certification (Korea)
- IRAM Certification (Argentina)
- Ecology Declaration (International)



## Product Regulatory Compliance Markings

This Intel® server system product is provided with the following regulatory marks.

**Table 9. Product Regulatory Compliance Markings**

Regulatory Compliance	Region	Marking
cULus Listing Marks	USA/Canada	
GS Mark	Germany	
CE Mark	Europe	 
FCC Marking (Class A)	USA	
EMC Marking (Class A)	Canada	This device complies with Part 15 of the FCC Rules. Operation of this device is subject to the following two conditions: (1) This device may not cause harmful interference, and (2) This device must accept any interference received, including interference that may cause undesired operation. Manufactured by Intel Corporation
		CANADA ICES-003 CLASS A CANADA NMB-003 CLASSE A

**Table 9. Product Regulatory Compliance Markings**

Regulatory Compliance	Region	Marking
C-Tick Mark	Australia / New Zealand	
VCCI Marking (Class A)	Japan	<p data-bbox="911 510 1276 642">この装置は、クラス A 情報技術装置です。この装置を家庭環境で使用すると電波妨害を引き起こすことがあります。この場合には使用者が適切な対策を講ずるよう要求されることがあります。VCCI-A</p>
BSMI Certification Number & Class A Warning	Taiwan	 <div data-bbox="911 835 1338 940" style="border: 1px solid black; padding: 5px;"> <p><b>警告使用者：</b>                      這是甲類的資訊產品，在居住的環境中使用時，可能會造成射頻干擾，在這種情況下，使用者會被要求採取某些適當的對策</p> </div>
GOST R Marking	Russia	
RRL MIC Mark	Korea	 <p data-bbox="911 1178 1029 1199">인증번호: CPU</p>

# Electromagnetic Compatibility Notices

## FCC Verification Statement (USA)

This device complies with Part 15 of the FCC Rules. Operation is subject to the following two conditions: (1) this device may not cause harmful interference, and (2) this device must accept any interference received, including interference that may cause undesired operation.

For questions related to the EMC performance of this product, contact:

Intel Corporation  
5200 N.E. Elam Young Parkway  
Hillsboro, OR 97124-6497  
1-800-628-8686

This equipment has been tested and found to comply with the limits for a Class A digital device, pursuant to Part 15 of the FCC Rules. These limits are designed to provide reasonable protection against harmful interference in a residential installation. This equipment generates, uses, and can radiate radio frequency energy and, if not installed and used in accordance with the instructions, may cause harmful interference to radio communications. However, there is no guarantee that interference will not occur in a particular installation. If this equipment does cause harmful interference to radio or television reception, which can be determined by turning the equipment off and on, the user is encouraged to try to correct the interference by one or more of the following measures:

- Reorient or relocate the receiving antenna.
- Increase the separation between the equipment and the receiver.
- Connect the equipment to an outlet on a circuit other than the one to which the receiver is connected.
- Consult the dealer or an experienced radio/TV technician for help.

Any changes or modifications not expressly approved by the grantee of this device could void the user's authority to operate the equipment. The customer is responsible for ensuring compliance of the modified product.

Only peripherals (computer input/output devices, terminals, printers, etc.) that comply with FCC Class A or B limits may be attached to this computer product. Operation with noncompliant peripherals is likely to result in interference to radio and TV reception.

All cables used to connect to peripherals must be shielded and grounded. Operation with cables, connected to peripherals, that are not shielded and grounded may result in interference to radio and TV reception.

## Industry Canada (ICES-003)

---

Cet appareil numérique respecte les limites bruits radioélectriques applicables aux appareils numériques de Classe A prescrites dans la norme sur le matériel brouilleur: "Appareils Numériques", NMB-003 édictée par le Ministre Canadien des Communications.

---

English translation of the notice above:

This digital apparatus does not exceed the Class A limits for radio noise emissions from digital apparatus set out in the interference-causing equipment standard entitled: "Digital Apparatus," ICES-003 of the Canadian Department of Communications.

## Europe (CE Declaration of Conformity)

This product has been tested in accordance to, and complies with the Low Voltage Directive (73/23/EEC) and EMC Directive (89/336/EEC). The product has been marked with the CE Mark to illustrate its compliance.

## VCCI (Japan)

この装置は、情報処理装置等電波障害自主規制協議会（VCCI）の基準に基づくクラス A 情報技術装置です。この装置を家庭環境で使用すると電波妨害を引き起こすことがあります。この場合には使用者が適切な対策を講ずるよう要求されることがあります。

English translation of the preceding notice:

This is a Class A product based on the standard of the Voluntary Control Council for Interference (VCCI) from Information Technology Equipment. If this is used near a radio or television receiver in a domestic environment, it may cause radio interference. Install and use the equipment according to the instruction manual.

## BSMI (Taiwan)

**警告使用者：**  
這是甲類的資訊產品，在居住的環境中使用時，可能會造成射頻干擾，在這種情況下，使用者會被要求採取某些適當的對策

The BSMI Certification Marking and EMC warning is located on the outside rear area of the product.



## Korean Compliance (RRL)

Following is the RRL certification information for Korea.



1. 기기의 명칭(모델명) :
2. 인증번호 :
3. 인증받은 자의 상호 :
4. 제조년월일 :
5. 제조자/제조국가 :

English translation of the notice above:

1. Type of Equipment (Model Name): On License and Product
2. Certification No.: On RRL certificate. Obtain certificate from local Intel representative
3. Name of Certification Recipient: Intel Corporation
4. Date of Manufacturer: Refer to date code on product
5. Manufacturer/Nation: Intel Corporation/Refer to country of origin marked on product

## Regulated Specified Components

To maintain the UL listing and compliance to other regulatory certifications and/or declarations, the following regulated components must be used and conditions adhered to. Interchanging or use of other components will void the UL listing and other product certifications and approvals.

Updated product information for configurations can be found on the Intel Server Builder Web site at the following URL: <http://channel.intel.com/go/serverbuilder>

If you do not have access to Intel's Web address, please contact your local Intel representative.

- **Server Chassis:** (base chassis is provided with power supply and fans) - UL listed.
- **Server board:** you must use an Intel server board - UL recognized.

- **Add-in boards:** must have a printed wiring board flammability rating of minimum UL94V-1. Add-in boards containing external power connectors and/or lithium batteries must be UL recognized or UL listed. Any add-in board containing modem telecommunication circuitry must be UL listed. In addition, the modem must have the appropriate telecommunications, safety, and EMC approvals for the region in which it is sold.
- **Peripheral Storage Devices:** must be a UL recognized or UL listed accessory and TUV or VDE licensed. Maximum power rating of any one device is 19 watts. Total server configuration is not to exceed the maximum loading conditions of the power supply.

## Restriction of Hazardous Substances (RoHS) Compliance

Intel has a system in place to restrict the use of banned substances in accordance with the European Directive 2002/95/EC. Compliance is based on declaration that materials banned in the RoHS Directive are either (1) below all applicable substance threshold limits or (2) an approved/pending RoHS exemption applies.

*Note: RoHS implementing details are not fully defined and may change.*

Threshold limits and banned substances are noted below.

- Quantity limit of 0.1% by mass (1000 PPM) for:
  - Lead
  - Mercury
  - Hexavalent Chromium
  - Polybrominated Biphenyls Diphenyl Ethers (PBDE)
- Quantity limit of 0.01% by mass (100 PPM) for:
  - Cadmium

## End-of-Life / Product Recycling

Product recycling and end-of-life take-back systems and requirements vary by country. Contact the retailer or distributor of this product for information about product recycling and / or take-back.

# Appendix E: Warranty

---

## Limited Warranty for Intel® Chassis Subassembly Products

Intel warrants that the Products (defined herein as the Intel® chassis subassembly and all of its various components and software delivered with or as part of the Products) to be delivered hereunder, if properly used and installed, will be free from defects in material and workmanship and will substantially conform to Intel's publicly available specifications for a period of three (3) years after the date the Product was purchased from an Intel authorized distributor. Software of any kind delivered with or as part of products is expressly provided "as is" unless specifically provided for otherwise in any software license accompanying the software.

If any Product furnished by Intel which is the subject of this Limited Warranty fails during the warranty period for reasons covered by this Limited Warranty, Intel, at its option, will:

- REPAIR the Product by means of hardware and/or software; OR
- REPLACE the Product with another Product; OR
- REFUND the then-current value of the Product if Intel is unable to repair or replace the Product.

If such Product is defective, transportation charges for the return of Product to buyer within the USA will be paid by Intel. For all other locations, the warranty excludes all costs of shipping, customs clearance, and other related charges. Intel will have a reasonable time to make repairs or to replace Product or to refund the then-current value of the Product.

In no event will Intel be liable for any other costs associated with the replacement or repair of Product, including labor, installation or other costs incurred by buyer and in particular, any costs relating to the removal or replacement of any product soldered or otherwise permanently affixed to any printed circuit board.

This Limited Warranty, and any implied warranties that may exist under state law, apply only to the original purchaser of the Product.

## Extent of Limited Warranty

Intel does not warrant that Products to be delivered hereunder, whether delivered stand-alone or integrated with other Products, including without limitation semiconductor components, will be free from design defects or errors known as "errata." Current characterized errata are available upon request.

This Limited Warranty does not cover damages due to external causes, including accident, problems with electrical power, usage not in accordance with product instructions, misuse, neglect, alteration, repair, improper installation, or improper testing.

## Warranty Limitations and Exclusions

These warranties replace all other warranties, expressed or implied including, but not limited to, the implied warranties of merchantability and fitness for a particular purpose. Intel makes no expressed warranties beyond those stated here. Intel disclaims all other warranties, expressed or implied including, without limitation, implied warranties of merchantability and fitness for a particular purpose. Some jurisdictions do not allow the exclusion of implied warranties, so this limitation may not apply.

All expressed and implied warranties are limited in duration to the limited warranty period. No warranties apply after that period. Some jurisdictions do not allow limitations on how long an implied warranty lasts, so this limitation may not apply to you.

## Limitations of Liability

Intel's responsibility under this, or any other warranty, implied or expressed, is limited to repair, replacement, or refund, as set forth above. These remedies are the sole and exclusive remedies for any breach of warranty. Intel is not responsible for direct, special, incidental, or consequential damages resulting from any breach of warranty under another legal theory including, but not limited to, lost profits, downtime, goodwill, damage to or replacement of equipment and property, and any costs of recovering, reprogramming, or reproducing any program or data stored in or used with a system containing this product. Some jurisdictions do not allow the exclusion or limitation of incidental or consequential damages, so the above limitations or exclusions may not apply to you.

This limited warranty gives you specific legal rights, and you may also have other rights that vary from jurisdiction to jurisdiction.

Any and all disputes arising under or related to this Limited Warranty shall be adjudicated in the following forums and governed by the following laws: for the United States of America, Canada, North America, and South America, the forum shall be Santa Clara, California, USA, and the applicable law shall be that of the State of California, USA; for the Asia Pacific region, the forum shall be Singapore and the applicable law shall be that of Singapore; for Europe and the rest of the world, the forum shall be London and the applicable law shall be that of the United Kingdom.

In the event of any conflict between the English language version and any other translated version(s) of this Limited Warranty, the English language version shall control.

## How to Obtain Warranty Service

To obtain warranty service for this Product, you may contact Intel or your authorized distributor.

- North America and Latin America To obtain warranty repair for the product, please go to the following Web site to obtain instructions: <http://support.intel.com/support/motherboards/draform.htm>
- In Europe and in Asia Contact your original authorized distributor for warranty service.

Any replacement Product is warranted under this written warranty and is subject to the same limitations and exclusions for the remainder of the original warranty period.

## Telephone Support

If you cannot find the information you need on Intel's World Wide Web site (<http://www.intel.com/>), call your local distributor or an Intel Customer Support representative. See “[Getting Help](#)” for telephone numbers.

## Returning a Defective Product

Before returning any product, call your authorized dealer/distribution authority.



# Appendix F: Troubleshooting

---

This chapter helps you identify and solve problems that might occur while you are using the system.

For any issue, first ensure you are using the latest firmware and files. Firmware upgrades include updates for BIOS, the Baseboard Management Controller (BMC), and the hot-swap controller (HSC). See [“Server System References”](#) for a link to the software updates. In addition to the server firmware and files, also update any drivers used for components you have installed in your system, such as video drivers, network drivers, and SATA drivers.

Intel provides a package called the "Platform Confidence Test" that may help with your diagnostics. See [“Server System References”](#) for a link to this software.

If you are unable to resolve your server problems on your own, see [“Getting Help”](#) for assistance.

## Resetting the System

Before going through in-depth troubleshooting, attempt first to reset your system using one of the methods below.

**Table 10. Resetting the System**

To do this	Press
Soft boot reset to clear the system memory and reload the operating system	<Ctrl+Alt+Del>
Clear system memory, restart POST, and reload the operating system	Reset button
Cold boot reset. Turn the system power off and then on. This clears system memory, restarts POST, reloads the operating system, and halts power to all peripherals	Power off/on button
Reset the BMC and get it back to a stable state	Remove AC power from the server for one minute

# Problems following Initial System Installation

Problems that occur at initial system startup are usually caused by an incorrect installation or configuration. Hardware failure is a less frequent cause. If the problem you are experiencing is with a specific software application, see [“Problems with Newly Installed Application Software”](#).

## First Steps Checklist

- Is AC power available at the wall outlet?
- Are the power supplies plugged in? Check the AC cable(s) on the back of the chassis and at the AC source.
- Are all cables correctly connected and secured?
- Are the processors fully seated in their sockets on the server board?
- Are all standoffs in the proper location and not touching any components, causing a potential short?
- Are all add-in PCI boards fully seated in their slots on the server board?
- Are all jumper settings on the server board correct?
- Are all jumper and switch settings on add-in boards and peripheral devices correct? To check these settings, refer to the manufacturer's documentation that comes with them. If applicable, ensure that there are no conflicts—for example, two add-in boards sharing the same interrupt.
- Are all peripheral devices installed correctly?
- If the system has a hard disk drive, is it properly formatted or configured?
- Are all device drivers properly installed?
- Are the configuration settings made in Setup correct?
- Is the operating system properly loaded? See the operating system documentation.
- Did you press the system power on/off switch on the front panel to turn the server on (power on light should be lit)?
- Is the system power cord properly connected to the system and plugged into a NEMA 5 15R outlet for 100-120V or a NEMA 6-15R outlet for 200-240V ?
- Are all integrated components from the tested components lists? Check the tested memory, and chassis lists, as well as the supported hardware and operating system list. See [“Server System References”](#) for links to the tested component lists.



# Hardware Diagnostic Testing

This section provides a more detailed approach to identifying a hardware problem and locating its source.

**Caution:** *Turn off devices before disconnecting cables: Before disconnecting any peripheral cables from the system, turn off the system and any external peripheral devices. Failure to do so can cause permanent damage to the system and/or the peripheral devices.*

1. Turn off the system and all external peripheral devices. Disconnect each device from the system, except for the keyboard and the video monitor.
2. Make sure the system power cord is plugged into a properly grounded AC outlet.
3. Make sure your video display monitor and keyboard are correctly connected to the system. Turn on the video monitor. Set its brightness and contrast controls to at least two thirds of their maximum ranges (see the documentation supplied with your video display monitor).
4. If the operating system normally loads from the hard disk drive, make sure there is no CD-ROM / DVD disk in the optical drive.
5. If the power LED does light, attempt to boot from a USB floppy or from a CD-ROM disk.
6. Turn on the system. If the power LED does not light, see [“Power Light Does Not Light”](#).

## Verifying Proper Operation of Key System Lights

As POST determines the system configuration, it tests for the presence of each mass storage device installed in the system. As each device is checked, its activity light should turn on briefly. Check for the following:

- Does the drive activity light turn on briefly? If not, see [“Drive Activity Light Does Not Light”](#).

## Confirming Loading of the Operating System

Once the system boots up, the operating system prompt appears on the screen. The prompt varies according to the operating system. If the operating system prompt does not appear, see [“No Characters Appear on Screen”](#).

## Specific Problems and Corrective Actions

This section provides possible solutions for these specific problems:

- Power light does not light.
- No characters appear on screen.

- Characters on the screen appear distorted or incorrect.
- System cooling fans do not rotate.
- Diskette drive activity light does not light.
- Hard disk drive activity light does not light.
- CD-ROM drive activity light does not light.
- There are problems with application software.
- The bootable CD-ROM is not detected.

Try the solutions below in the order given. If you cannot correct the problem, contact your service representative or authorized dealer for help.

## Power Light Does Not Light

Check the following:

- Did you press the power-on button?
- Is the system operating normally? If so, the power LED might be defective or the connection from the control panel to the server board might be loose.
- Have you securely plugged the server AC power cord into the power supply?
- Some ATX power supplies have a power switch on the back of the power supply, next to the fan. If your system has one, is it turned on?
- Remove all add-in cards and see if the system boots. If successful, add the cards back in one at a time with a reboot between each addition.
- Make sure the memory DIMMs comply with the system requirements.
- Make sure the memory DIMMs have been populated according to the system requirements.
- Remove the memory DIMMs and re-seat them.
- Make sure the processor(s) comply with the system requirements.
- Make sure the processor(s) have been populated according to the system requirements.
- Remove the processor(s) and re-seat them.
- Make sure the chassis standoffs are installed only below mounting holes. Misplaced standoffs can contact the pins on the bottom of the server board and cause a short.

## No Characters Appear on Screen

Check the following:

- Is the keyboard functioning? Test it by turning the "Num Lock" function on and off to make sure the Num Lock light is functioning.

- Is the video monitor plugged in and turned on? If you are using a switch box, is it switched to the correct system?
- Are the brightness and contrast controls on the video monitor properly adjusted?
- Is the video monitor signal cable properly installed?
- Does this video monitor work correctly if plugged into a different system?
- Is the onboard video controller enabled in the BIOS?
- Remove all add-in cards and see if the video returns. If successful, add the cards back in one at a time with a reboot between each addition.
- Make sure the memory DIMMs comply with the system requirements.
- Make sure the memory DIMMs have been populated according to the system requirements.
- Remove the memory DIMMs and re-seat them.
- Make sure the processor(s) comply with the system requirements.
- Make sure the processor(s) have been populated according to the system requirements.
- Remove the processor(s) and re-seat them.

If you are using an add-in video controller board, do the following:

1. Verify that the video works using the onboard video controller.
2. Verify that the video controller board is fully seated in the server board connector.
3. Reboot the system for changes to take effect.
4. If there are still no characters on the screen after you reboot the system and POST emits a beep code, write down the beep code you hear. This information is useful for your service representative.
5. If you do not receive a beep code and characters do not appear, the video display monitor or video controller may have failed. Contact your service representative or authorized dealer for help.

## Characters Are Distorted or Incorrect

Check the following:

- Are the brightness and contrast controls properly adjusted on the video monitor? See the manufacturer's documentation.
- Are the video monitor's signal and power cables properly installed?
- Does this video monitor work correctly if plugged into a different system?

## System Cooling Fans Do Not Rotate Properly

If the system cooling fans are not operating properly, it is an indication of possible system component failure.

Check the following:

- Is the power-on light lit? If not, see “[Power Light Does Not Light](#)”.
- If your system has LED lights for the fans, is one or more of these LEDs lit?
- Are any other control panel LEDs lit?
- Have any of the fan motors stopped? Use the server management subsystem to check the fan status.
- Have your fans speeded up in response to an overheating situation?
- Have your fans speeded up in response to a fan that has failed?
- Are the fan power connectors properly connected to the server board?
- Is the cable from the control panel board connected to the both the control panel board and to the server board?
- Are the power supply cables properly connected to the server board?
- Are there any shorted wires caused by pinched-cables or have power connector plugs been forced into power connector sockets the wrong way?

## Drive Activity Light Does Not Light

Check the following:

- Are the drive's power and signal cables properly installed?
- Are all relevant switches and jumpers on the drive set correctly?
- Is the drive properly configured?
- Is the drive activity light always on? If so, the signal cable may be plugged in incorrectly.

## CD-ROM Drive or DVD-ROM Drive Activity Light Does Not Light

Check the following:

- Are the CD-ROM/DVD-ROM drive's power and signal cables properly installed?
- Are all relevant switches and jumpers on the drive set correctly?
- Is the drive properly configured?

## Cannot Connect to a Server

- Make sure the network cable is securely attached to the correct connector at the system back panel.
- Try a different network cable.

- Make sure you are using the correct and the current drivers. See [“Server System References”](#) for a link to the current drivers.
- Make sure the driver is loaded and the protocols are bound.
- Make sure the hub port is configured for the same duplex mode as the network controller.
- Make sure the correct networking software is installed.
- If you are directly connecting two servers (without a hub), you will need a crossover cable.
- Check the network controller LEDs next to the NIC connectors.

## Problems with Network

### The server hangs when the drivers are loaded

- Certain drivers may require interrupts that are not shared with other PCI drivers. For these drivers, it may be necessary to alter settings so that interrupts are not shared. See the documentation that came with your PCI card(s) for information on changing interrupts.

### Diagnostics pass but the connection fails

- Make sure the network cable is securely attached.
- Make sure you specify the correct frame type in your NET.CFG file.
- The controller stopped working when an add-in adapter was installed.
- Make sure the cable is connected to the port from the onboard network controller.
- Make sure your BIOS is current. See [“Server System References”](#) for a link to the current version.
- Make sure the other adapter supports shared interrupts. Make sure your operating system supports shared interrupts.
- Try reseating the add-in adapter.

### The add-in adapter stopped working without apparent cause

- Reseat the adapter.
- Put the adapter in a different slot.
- The network driver files may be corrupt or deleted. Delete and then reinstall the drivers.
- Run diagnostics.

## System Boots when Installing PCI Card

System Management features require full-time "standby" power. This means some parts of the system have power going to them whenever the power cord is plugged in, even if you have turned the system power off with the power button on the front panel. If you install a PCI card with the AC power cord plugged in, a signal may be sent to command the system to boot. Before installing a PCI card, you should always:

- Turn off the server power by using the power button on the front of the system.
- Unplug the AC power cord(s) from the server.

## Problems with Newly Installed Application Software

Problems that occur when you run new application software are usually related to the software, not the server hardware. Faulty equipment is unlikely, especially if other software runs correctly.

Check the following:

- Make sure the system meets the minimum hardware requirements for the software. See the software documentation.
- Make sure the software is properly installed and configured for the system. See the software documentation.
- Use only an authorized copy. Unauthorized copies often do not work.
- If you are running the software from a CD-ROM or DVD-ROM, try a different disk.
- Make sure the correct device drivers installed.

If the problems persist, contact the software vendor's customer service representative.

## Problems with Application Software that Ran Correctly Earlier

Problems that occur after the system hardware and software have been running correctly sometimes indicate equipment failure. However, they can also be caused by file corruption or changes to the software configuration.

Check the following:

- If you are running the software from a CD-ROM or DVD-ROM, try a different disk.
- Check your system for a virus infection.
- Uninstall and reinstall the software. Make sure all necessary files are installed.
- If the problems are intermittent, there may be a loose cable, dirt in the keyboard (if keyboard input is incorrect), a marginal power supply, or other random component failures.
- If you suspect that a transient voltage spike, power outage, or brownout might have occurred, reload the software and try running it again. Symptoms of voltage spikes

include a flickering video display, unexpected system reboots, and the system not responding to user commands.

***Note:** Random errors in data files: If you are getting random errors in your data files, they may be getting corrupted by voltage spikes on your power line. If you are experiencing any of the above symptoms that might indicate voltage spikes on the power line, you may want to install a surge suppressor between the power outlet and the system power cord.*

## Devices are not Recognized under Device Manager (Microsoft\* Windows\* Operating System)

The Microsoft\* Windows\* operating systems do not include all of the drivers for the Intel® chipsets, onboard NICs, and other components. See [“Server System References”](#) for a link to the current drivers and chipset files.

## Hard Drive(s) are not Recognized

Check the following:

- Make sure the drive is not disabled in BIOS Setup.
- Make sure the drive is connected correctly and that is plugged into the power supply.
- Make sure the drive is compatible. See [“Server System References”](#) for a link to the tested drives.
- Make sure you have not exceeded the power budget for the server. See [“Server System References”](#) for a link to software to check your power budget.
- If using SCSI drives, verify that each SCSI ID number is unique on the SCSI bus. See your drive documentation for details on setting the SCSI ID for your drives.
- If using ATA drives, verify that the master/slave settings are set correctly. See your drive documentation for details on setting the master/slave settings.
- If using a RAID configuration with SCSI or SATA drives, make sure the RAID card is installed correctly.

## Bootable CD-ROM Disk Is Not Detected

Check the following:

- Make sure the BIOS is configured to allow the CD-ROM to be the first bootable device.

## LED Information

The Intel® Server Board S5000PAL includes LEDs that can aid in troubleshooting your system. A table of these LEDs with a description of their use is listed below.

**Table 11. LED Information**

LED Name	Function	Location	LED Color	Notes
Power	Indicates system power is on or off	Front control panel	Green	Off = Power is off or in sleep state S5 On = Power is on or in sleep state S0
ID	Aid in server identification from the back panel	Front control panel and board rear left corner	Blue	Press ID LED button or use Server Management software to turn the LED on and off.
System Status	Visible fault warning	Control panel and board rear left corner	Green or Amber	Green = No Fault Green blinking = degraded condition Amber blinking = non-critical error Amber = critical or non-recoverable error

## BIOS POST Beep Codes

The table below lists the POST error beep codes. Prior to system video initialization, the BIOS uses these beep codes to inform users of error conditions. Please note that not all error conditions are supported by BIOS beep codes.

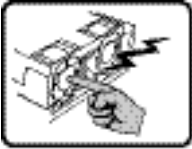
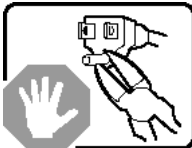

**Table 12. POST Error Beep Codes**

Number of Beeps	Reason for Beeps and Action to Take
1, 2, or 3	Memory error. Reseat the memory or replace the DIMMs with known good modules.
4 - 7 or 9 - 11	Fatal error indicating a possible serious system problem. Remove all add-in cards and re-start the system. If the error still occurs, contact your system manufacturer. If the beep codes are not generated after the add-in cards are removed, insert the cards one at a time, booting the system between each card addition, until the beeps again occur to reveal the malfunctioning card.
8	Replace or reseat the system video add-in card. If on-board video is being used, the server board may be faulty.





# Appendix G: Installation/Assembly Safety Instructions

## English

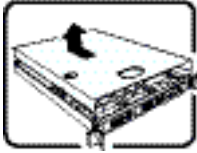
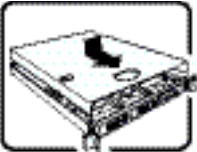
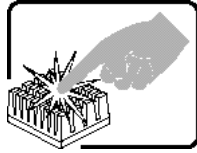
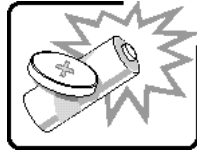
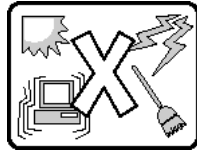
	<p>The power supply in this product contains no user-serviceable parts. Refer servicing only to qualified personnel.</p>
	<p>Do not attempt to modify or use the supplied AC power cord if it is not the exact type required. A product with more than one power supply will have a separate AC power cord for each supply.</p>
	<p>The power button on the system does not turn off system AC power. To remove AC power from the system, you must unplug each AC power cord from the wall outlet or power supply.</p> <p>The power cord(s) is considered the disconnect device to the main (AC) power. The socket outlet that the system plugs into shall be installed near the equipment and shall be easily accessible.</p>
	<p><b>SAFETY STEPS:</b> Whenever you remove the chassis covers to access the inside of the system, follow these steps:</p> <ol style="list-style-type: none"> <li>1. Turn off all peripheral devices connected to the system.</li> <li>2. Turn off the system by pressing the power button.</li> <li>3. Unplug all AC power cords from the system or from wall outlets.</li> <li>4. Label and disconnect all cables connected to I/O connectors or ports on the back of the system.</li> <li>5. Provide some electrostatic discharge (ESD) protection by wearing an antistatic wrist strap attached to chassis ground of the system-any unpainted metal surface-when handling components.</li> <li>6. Do not operate the system with the chassis covers removed.</li> </ol>

	<p>After you have completed the six SAFETY steps above, you can remove the system covers. To do this:</p> <ol style="list-style-type: none"> <li>1. Unlock and remove the padlock from the back of the system if a padlock has been installed.</li> <li>2. Remove and save all screws from the covers.</li> <li>3. Remove the cover(s).</li> </ol>
	<p>For proper cooling and airflow, always reinstall the chassis covers before turning on the system. Operating the system without the covers in place can damage system parts. To install the covers:</p> <ol style="list-style-type: none"> <li>1. Check first to make sure you have not left loose tools or parts inside the system.</li> <li>2. Check that cables, add-in boards, and other components are properly installed.</li> <li>3. Attach the covers to the chassis with the screws removed earlier, and tighten them firmly.</li> <li>4. Insert and lock the padlock to the system to prevent unauthorized access inside the system.</li> <li>5. Connect all external cables and the AC power cord(s) to the system.</li> </ol>
	<p>A microprocessor and heat sink may be hot if the system has been running. Also, there may be sharp pins and edges on some board and chassis parts. Contact should be made with care. Consider wearing protective gloves.</p>
	<p>Danger of explosion if the battery is incorrectly replaced. Replace only with the same or equivalent type recommended by the equipment manufacturer. Dispose of used batteries according to manufacturer's instructions.</p>
	<p>The system is designed to operate in a typical office environment. Choose a site that is:</p> <ul style="list-style-type: none"> <li>• Clean and free of airborne particles (other than normal room dust).</li> <li>• Well ventilated and away from sources of heat including direct sunlight.</li> <li>• Away from sources of vibration or physical shock.</li> <li>• Isolated from strong electromagnetic fields produced by electrical devices.</li> <li>• In regions that are susceptible to electrical storms, we recommend you plug your system into a surge suppresser and disconnect telecommunication lines to your modem during an electrical storm.</li> <li>• Provided with a properly grounded wall outlet.</li> <li>• Provided with sufficient space to access the power supply cord(s), because they serve as the product's main power disconnect.</li> </ul>

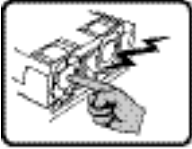
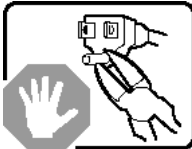

## Deutsch

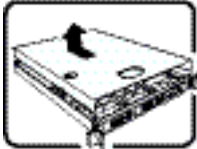
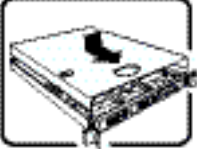
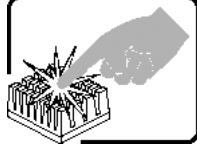
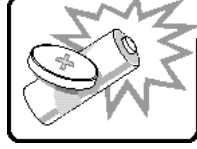
	<p>Benutzer können am Netzgerät dieses Produkts keine Reparaturen vornehmen. Das Produkt enthält möglicherweise mehrere Netzgeräte. Wartungsarbeiten müssen von qualifizierten Technikern ausgeführt werden.</p>
	<p>Versuchen Sie nicht, das mitgelieferte Netzkabel zu ändern oder zu verwenden, wenn es sich nicht genau um den erforderlichen Typ handelt. Ein Produkt mit mehreren Netzgeräten hat für jedes Netzgerät ein eigenes Netzkabel.</p>
	<p>Der Wechselstrom des Systems wird durch den Ein-/Aus-Schalter für Gleichstrom nicht ausgeschaltet. Ziehen Sie jedes Wechselstrom-Netzkabel aus der Steckdose bzw. dem Netzgerät, um den Stromanschluß des Systems zu unterbrechen.</p>
	<p><b>SICHERHEISSMASSNAHMEN:</b> Immer wenn Sie die Gehäuseabdeckung abnehmen um an das Systeminnere zu gelangen, sollten Sie folgende Schritte beachten:</p> <ol style="list-style-type: none"><li>1. Schalten Sie alle an Ihr System angeschlossenen Peripheriegeräte aus.</li><li>2. Schalten Sie das System mit dem Hauptschalter aus.</li><li>3. Ziehen Sie den Stromanschlußstecker Ihres Systems aus der Steckdose.</li><li>4. Auf der Rückseite des Systems beschriften und ziehen Sie alle Anschlußkabel von den I/O Anschlüssen oder Ports ab.</li><li>5. Tragen Sie ein geerdetes Antistatik Gelenkband, um elektrostatische Ladungen (ESD) über blanke Metallstellen bei der Handhabung der Komponenten zu vermeiden.</li><li>6. Schalten Sie das System niemals ohne ordnungsgemäß montiertes Gehäuse ein.</li></ol>

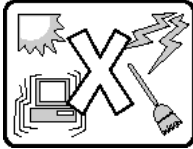
	<p><b>SICHERHEISSMASSNAHMEN:</b> Immer wenn Sie die Gehäuseabdeckung abnehmen um an das Systeminnere zu gelangen, sollten Sie folgende Schritte beachten:</p> <ol style="list-style-type: none"> <li>1. Schalten Sie alle an Ihr System angeschlossenen Peripheriegeräte aus.</li> <li>2. Schalten Sie das System mit dem Hauptschalter aus.</li> <li>3. Ziehen Sie den Stromanschlußstecker Ihres Systems aus der Steckdose.</li> <li>4. Auf der Rückseite des Systems beschriften und ziehen Sie alle Anschlußkabel von den I/O Anschlüssen oder Ports ab.</li> <li>5. Tragen Sie ein geerdetes Antistatik Gelenkband, um elektrostatische Ladungen (ESD) über blanke Metallstellen bei der Handhabung der Komponenten zu vermeiden.</li> <li>6. Schalten Sie das System niemals ohne ordnungsgemäß montiertes Gehäuse ein.</li> </ol>
	<p>Zur ordnungsgemäßen Kühlung und Lüftung muß die Gehäuseabdeckung immer wieder vor dem Einschalten installiert werden. Ein Betrieb des Systems ohne angebrachte Abdeckung kann Ihrem System oder Teile darin beschädigen. Um die Abdeckung wieder anzubringen:</p> <ol style="list-style-type: none"> <li>1. Vergewissern Sie sich, daß Sie keine Werkzeuge oder Teile im Innern des Systems zurückgelassen haben.</li> <li>2. Überprüfen Sie alle Kabel, Zusatzkarten und andere Komponenten auf ordnungsgemäßen Sitz und Installation.</li> <li>3. Bringen Sie die Abdeckungen wieder am Gehäuse an, indem Sie die zuvor gelösten Schrauben wieder anbringen. Ziehen Sie diese gut an.</li> <li>4. Bringen Sie die Verschlusseinrichtung (Padlock) wieder an und schließen Sie diese, um ein unerlaubtes Öffnen des Systems zu verhindern.</li> <li>5. Schließen Sie alle externen Kabel und den AC Stromanschlußstecker Ihres Systems wieder an.</li> </ol>
	<p>Der Mikroprozessor und der Kühler sind möglicherweise erhitzt, wenn das System in Betrieb ist. Außerdem können einige Platinen und Gehäuseteile scharfe Spitzen und Kanten aufweisen. Arbeiten an Platinen und Gehäuse sollten vorsichtig ausgeführt werden. Sie sollten Schutzhandschuhe tragen.</p>
	<p>Bei falschem Einsetzen einer neuen Batterie besteht Explosionsgefahr. Die Batterie darf nur durch denselben oder einen entsprechenden, vom Hersteller empfohlenen Batterietyp ersetzt werden. Entsorgen Sie verbrauchte Batterien den Anweisungen des Herstellers entsprechend.</p>

	<p>Das System wurde für den Betrieb in einer normalen Büroumgebung entwickelt. Der Standort sollte:</p> <ul style="list-style-type: none"> <li>• "sauber und staubfrei sein (Hausstaub ausgenommen);</li> <li>• "gut gelüftet und keinen Heizquellen ausgesetzt sein (einschließlich direkter Sonneneinstrahlung);</li> <li>• "keinen Erschütterungen ausgesetzt sein;</li> <li>• "keine starken, von elektrischen Geräten erzeugten elektromagnetischen Felder aufweisen;</li> <li>• "in Regionen, in denen elektrische Stürme auftreten, mit einem Überspannungsschutzgerät verbunden sein; während eines elektrischen Sturms sollte keine Verbindung der Telekommunikationsleitungen mit dem Modem bestehen;</li> <li>• "mit einer geerdeten Wechselstromsteckdose ausgerüstet sein;</li> <li>• "über ausreichend Platz verfügen, um Zugang zu den Netzkabeln zu gewährleisten, da der Stromanschluß des Produkts hauptsächlich über die Kabel unterbrochen wird</li> </ul>
---	--

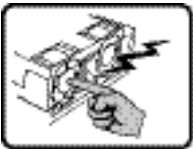
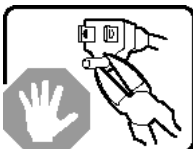
## Français

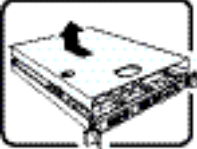
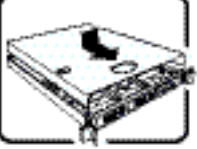
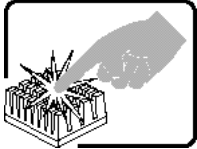

	<p>Le bloc d'alimentation de ce produit ne contient aucune pièce pouvant être réparée par l'utilisateur. Ce produit peut contenir plus d'un bloc d'alimentation. Veuillez contacter un technicien qualifié en cas de problème.</p>
	<p>Ne pas essayer d'utiliser ni modifier le câble d'alimentation CA fourni, s'il ne correspond pas exactement au type requis. Le nombre de câbles d'alimentation CA fournis correspond au nombre de blocs d'alimentation du produit</p>
	<p>Notez que le commutateur CC de mise sous tension /hors tension du panneau avant n'éteint pas l'alimentation CA du système. Pour mettre le système hors tension, vous devez débrancher chaque câble d'alimentation de sa prise.</p>

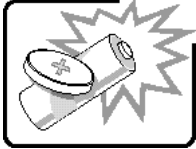
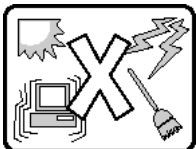
	<p><b>CONSIGNES DE SÉCURITÉ</b> -Lorsque vous ouvrez le boîtier pour accéder à l'intérieur du système, suivez les consignes suivantes:</p> <ol style="list-style-type: none"> <li>1. Mettez hors tension tous les périphériques connectés au système.</li> <li>2. Mettez le système hors tension en mettant l'interrupteur général en position OFF (bouton-poussoir).</li> <li>3. Débranchez tous les cordons d'alimentation c.a. du système et des prises murales.</li> <li>4. Identifiez et débranchez tous les câbles reliés aux connecteurs d'E-S ou aux accès derrière le système.</li> <li>5. Pour prévenir les décharges électrostatiques lorsque vous touchez aux composants, portez une bande antistatique pour poignet et reliez-la à la masse du système (toute surface métallique non peinte du boîtier).</li> <li>6. Ne faites pas fonctionner le système tandis que le boîtier est ouvert.</li> </ol>
	<p>Une fois TOUTES les étapes précédentes accomplies, vous pouvez retirer les panneaux du système. Procédez comme suit:</p> <ol style="list-style-type: none"> <li>1. Si un cadenas a été installé sur à l'arrière du système, déverrouillez-le et retirez-le.</li> <li>2. Retirez toutes les vis des panneaux et mettez-les dans un endroit sûr.</li> <li>3. Retirez les panneaux.</li> </ol>
	<p>Afin de permettre le refroidissement et l'aération du système, réinstallez toujours les panneaux du boîtier avant de mettre le système sous tension. Le fonctionnement du système en l'absence des panneaux risque d'endommager ses pièces. Pour installer les panneaux, procédez comme suit:</p> <ol style="list-style-type: none"> <li>1. Assurez-vous de ne pas avoir oublié d'outils ou de pièces démontées dans le système.</li> <li>2. Assurez-vous que les câbles, les cartes d'extension et les autres composants sont bien installés.</li> <li>3. Revissez solidement les panneaux du boîtier avec les vis retirées plus tôt.</li> <li>4. Remettez le cadenas en place et verrouillez-le afin de prévenir tout accès non autorisé à l'intérieur du système.</li> <li>5. Rebranchez tous les cordons d'alimentation c. a. et câbles externes au système.</li> </ol>
	<p>Le microprocesseur et le dissipateur de chaleur peuvent être chauds si le système a été sous tension. Faites également attention aux broches aiguës des cartes et aux bords tranchants du capot. Nous vous recommandons l'usage de gants de protection.</p>

	<p>Danger d'explosion si la batterie n'est pas remontée correctement. Remplacer uniquement avec une batterie du même type ou d'un type équivalent recommandé par le fabricant. Disposez des piles usées selon les instructions du fabricant.</p>
	<p>Le système a été conçu pour fonctionner dans un cadre de travail normal. L'emplacement choisi doit être:</p> <ul style="list-style-type: none"> <li>• "Propre et dépourvu de poussière en suspension (sauf la poussière normale).</li> <li>• "Bien aéré et loin des sources de chaleur, y compris du soleil direct.</li> <li>• "A l'abri des chocs et des sources de vibrations.</li> <li>• "Isolé de forts champs électromagnétiques générés par des appareils électriques.</li> <li>• "Dans les régions sujettes aux orages magnétiques il est recommandé de brancher votre système à un supresseur de surtension, et de débrancher toutes les lignes de télécommunications de votre modem durant un orage.</li> <li>• "Muni d'une prise murale correctement mise à la terre.</li> <li>• "Suffisamment spacieux pour vous permettre d'accéder aux câbles d'alimentation (ceux-ci étant le seul moyen de mettre le système hors tension).</li> </ul>

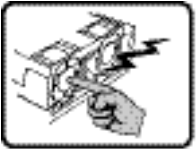
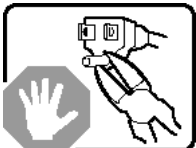
## Español

	<p>El usuario debe abstenerse de manipular los componentes de la fuente de alimentación de este producto, cuya reparación debe dejarse exclusivamente en manos de personal técnico especializado. Puede que este producto disponga de más de una fuente de alimentación</p>
	<p>No intente modificar ni usar el cable de alimentación de corriente alterna, si no corresponde exactamente con el tipo requerido. El número de cables suministrados se corresponden con el número de fuentes de alimentación de corriente alterna que tenga el producto</p>

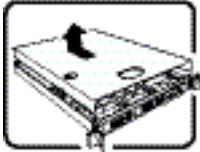
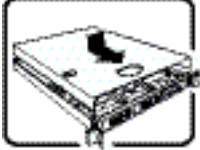
	<p>Nótese que el interruptor activado/desactivado en el panel frontal no desconecta la corriente alterna del sistema. Para desconectarla, deberá desenchufar todos los cables de corriente alterna de la pared o desconectar la fuente de alimentación.</p>
	<p><b>INSTRUCCIONES DE SEGURIDAD:</b> Cuando extraiga la tapa del chasis para acceder al interior del sistema, siga las siguientes instrucciones:</p> <ol style="list-style-type: none"> <li>1. Apague todos los dispositivos periféricos conectados al sistema.</li> <li>2. Apague el sistema presionando el interruptor encendido/apagado.</li> <li>3. Desconecte todos los cables de alimentación CA del sistema o de las tomas de corriente alterna.</li> <li>4. Identifique y desconecte todos los cables enchufados a los conectores E/S o a los puertos situados en la parte posterior del sistema.</li> <li>5. Cuando manipule los componentes, es importante protegerse contra la descarga electrostática (ESD). Puede hacerlo si utiliza una muñequera antiestática sujeta a la toma de tierra del chasis - o a cualquier tipo de superficie de metal sin pintar.</li> <li>6. No ponga en marcha el sistema si se han extraído las tapas del chasis.</li> </ol>
	<p>Después de completar las seis instrucciones de <b>SEGURIDAD</b> mencionadas, ya puede extraer las tapas del sistema. Para ello:</p> <ol style="list-style-type: none"> <li>1. Desbloquee y extraiga el bloqueo de seguridad de la parte posterior del sistema, si se ha instalado uno.</li> <li>2. Extraiga y guarde todos los tornillos de las tapas. Extraiga las tapas.</li> </ol>
	<p>Para obtener un enfriamiento y un flujo de aire adecuados, reinstale siempre las tapas del chasis antes de poner en marcha el sistema. Si pone en funcionamiento el sistema sin las tapas bien colocadas puede dañar los componentes del sistema. Para instalar las tapas:</p> <ol style="list-style-type: none"> <li>1. Asegúrese primero de no haber dejado herramientas o componentes sueltos dentro del sistema.</li> <li>2. Compruebe que los cables, las placas adicionales y otros componentes se hayan instalado correctamente.</li> <li>3. Incorpore las tapas al chasis mediante los tornillos extraídos anteriormente, tensándolos firmemente.</li> <li>4. Inserte el bloqueo de seguridad en el sistema y bloquéelo para impedir que pueda accederse al mismo sin autorización.</li> <li>5. Conecte todos los cables externos y los cables de alimentación CA al sistema.</li> </ol>

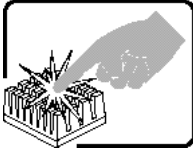
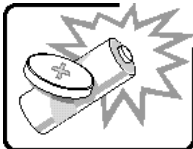
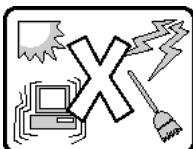

	<p>Si el sistema ha estado en funcionamiento, el microprocesador y el disipador de calor pueden estar aún calientes. También conviene tener en cuenta que en el chasis o en el tablero puede haber piezas cortantes o punzantes. Por ello, se recomienda precaución y el uso de guantes protectores.</p>
	<p>Existe peligro de explosión si la pila no se cambia de forma adecuada. Utilice solamente pilas iguales o del mismo tipo que las recomendadas por el fabricante del equipo. Para deshacerse de las pilas usadas, siga igualmente las instrucciones del fabricante.</p>
	<p>El sistema está diseñado para funcionar en un entorno de trabajo normal. Escoja un lugar:</p> <ul style="list-style-type: none"> <li>• "Limpio y libre de partículas en suspensión (salvo el polvo normal).</li> <li>• "Bien ventilado y alejado de fuentes de calor, incluida la luz solar directa.</li> <li>• "Alejado de fuentes de vibración.</li> <li>• "Aislado de campos electromagnéticos fuertes producidos por dispositivos eléctricos.</li> <li>• "En regiones con frecuentes tormentas eléctricas, se recomienda conectar su sistema a un eliminador de sobrevoltage y desconectar el módem de las líneas de telecomunicación durante las tormentas.</li> <li>• "Provisto de una toma de tierra correctamente instalada.</li> <li>• "Provisto de espacio suficiente como para acceder a los cables de alimentación, ya que éstos hacen de medio principal de desconexión del sistema.</li> </ul>

## Italiano

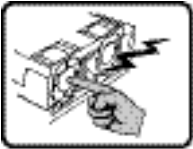
	<p>Rivolgersi ad un tecnico specializzato per la riparazione dei componenti dell'alimentazione di questo prodotto. È possibile che il prodotto disponga di più fonti di alimentazione.</p>
---	--

	<p>Non modificare o utilizzare il cavo di alimentazione in c.a. fornito dal produttore, se non corrisponde esattamente al tipo richiesto. Ad ogni fonte di alimentazione corrisponde un cavo di alimentazione in c.a. separato</p>
	<p>L'interruttore attivato/disattivato nel pannello anteriore non interrompe l'alimentazione in c.a. del sistema. Per interromperla, è necessario scollegare tutti i cavi di alimentazione in c.a. dalle prese a muro o dall'alimentazione di corrente.</p>
	<p><b>PASSI DI SICUREZZA:</b> Qualora si rimuovano le coperture del telaio per accedere all'interno del sistema, seguire i seguenti passi:</p> <ol style="list-style-type: none"> <li>1. Spegner tutti i dispositivi periferici collegati al sistema.</li> <li>2. Spegner il sistema, usando il pulsante spento/acceso dell'interruttore del sistema.</li> <li>3. Togliere tutte le spine dei cavi del sistema dalle prese elettriche.</li> <li>4. Identificare e sconnettere tutti i cavi attaccati ai collegamenti I/O od alle prese installate sul retro del sistema.</li> <li>5. Qualora si tocchino i componenti, proteggersi dallo scarico elettrostatico (SES), portando un cinghia anti-statica da polso che è attaccata alla presa a terra del telaio del sistema - qualsiasi superficie non dipinta - .</li> <li>6. Non far operare il sistema quando il telaio è senza le coperture.</li> </ol>
	<p>Dopo aver seguito i sei passi di SICUREZZA sopracitati, togliere le coperture del telaio del sistema come segue:</p> <ol style="list-style-type: none"> <li>1. Aprire e rimuovere il lucchetto dal retro del sistema qualora ve ne fosse uno installato.</li> <li>2. Togliere e mettere in un posto sicuro tutte le viti delle coperture.</li> <li>3. Togliere le coperture.</li> </ol>
	<p>Per il giusto flusso dell'aria e raffreddamento del sistema, rimettere sempre le coperture del telaio prima di riaccendere il sistema. Operare il sistema senza le coperture al loro proprio posto potrebbe danneggiare i componenti del sistema. Per rimettere le coperture del telaio:</p> <ol style="list-style-type: none"> <li>1. Controllare prima che non si siano lasciati degli attrezzi o dei componenti dentro il sistema.</li> <li>2. Controllare che i cavi, dei supporti aggiuntivi ed altri componenti siano stati installati appropriatamente.</li> <li>3. Attaccare le coperture al telaio con le viti tolte in precedenza e avvitarle strettamente.</li> <li>4. Inserire e chiudere a chiave il lucchetto sul retro del sistema per impedire l'accesso non autorizzato al sistema.</li> <li>5. Ricollegare tutti i cavi esterni e le prolunghe AC del sistema.</li> </ol>

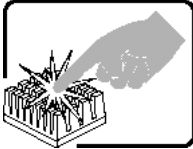
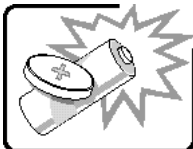
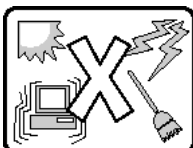
	<p>Se il sistema è stato a lungo in funzione, il microprocessore e il dissipatore di calore potrebbero essere surriscaldati. Fare attenzione alla presenza di piedini appuntiti e parti taglienti sulle schede e sul telaio. È consigliabile l'uso di guanti di protezione.</p>
	<p>Esiste il pericolo di un'esplosione se la pila non viene sostituita in modo corretto. Utilizzare solo pile uguali o di tipo equivalente a quelle consigliate dal produttore. Per disfarsi delle pile usate, seguire le istruzioni del produttore.</p>
	<p>Il sistema è progettato per funzionare in un ambiente di lavoro tipo. Scegliere una postazione che sia:</p> <ul style="list-style-type: none"> <li>• "Pulita e libera da particelle in sospensione (a parte la normale polvere presente nell'ambiente).</li> <li>• "Ben ventilata e lontana da fonti di calore, compresa la luce solare diretta.</li> <li>• "Al riparo da urti e lontana da fonti di vibrazione.</li> <li>• "Isolata dai forti campi magnetici prodotti da dispositivi elettrici.</li> <li>• "In aree soggette a temporali, è consigliabile collegare il sistema ad un limitatore di corrente. In caso di temporali, scollegare le linee di comunicazione dal modem.</li> <li>• "Dotata di una presa a muro correttamente installata.</li> <li>• "Dotata di spazio sufficiente ad accedere ai cavi di alimentazione, i quali rappresentano il mezzo principale di scollegamento del sistema.</li> </ul>



# Appendix H: Safety Information

---

## English

### Server Safety Information

This document applies to Intel® server boards, Intel® server chassis (pedestal and rack-mount) and installed peripherals. To reduce the risk of bodily injury, electrical shock, fire, and equipment damage, read this document and observe all warnings and precautions in this guide before installing or maintaining your Intel® server product.



In the event of a conflict between the information in this document and information provided with the product or on the website for a particular product, the product documentation takes precedence.



Your server should be integrated and serviced only by technically qualified persons.

You must adhere to the guidelines in this guide and the assembly instructions in your server manuals to ensure and maintain compliance with existing product certifications and approvals. Use only the described, regulated components specified in this guide. Use of other products / components will void the UL Listing and other regulatory approvals of the product, and may result in noncompliance with product regulations in the region(s) in which the product is sold.

### Safety Warnings and Cautions

To avoid personal injury or property damage, before you begin installing the product, read, observe, and adhere to all of the following safety instructions and information. The following safety symbols may be used throughout the documentation and may be marked on the product and / or the product packaging.

<b>CAUTION</b>	Indicates the presence of a hazard that may cause minor personal injury or property damage if the CAUTION is ignored.
<b>WARNING</b>	Indicates the presence of a hazard that may result in serious personal injury if the WARNING is ignored.
	Indicates potential hazard if indicated information is ignored.
	Indicates shock hazards that result in serious injury or death if safety instructions are not followed.
	Indicates hot components or surfaces.

	Indicates do not touch fan blades, may result in injury.
	Indicates to unplug all AC power cord(s) to disconnect AC power
	Please recycle battery

## Intended Application Uses

This product was evaluated as Information Technology Equipment (ITE), which may be installed in offices, schools, computer rooms, and similar commercial type locations. The suitability of this product for other product categories and environments (such as medical, industrial, residential, alarm systems, and test equipment), other than an ITE application, may require further evaluation.

## Site Selection

The system is designed to operate in a typical office environment. Choose a site that is:

- Clean, dry, and free of airborne particles (other than normal room dust).
- Well-ventilated and away from sources of heat including direct sunlight and radiators.
- Away from sources of vibration or physical shock.
- Isolated from strong electromagnetic fields produced by electrical devices.
- In regions that are susceptible to electrical storms, we recommend you plug your system into a surge suppresser and disconnect telecommunication lines to your modem during an electrical storm.
- Provided with a properly grounded wall outlet.
- Provided with sufficient space to access the power supply cord(s), because they serve as the product's main power disconnect.

## Equipment Handling Practices

Reduce the risk of personal injury or equipment damage:

- Conform to local occupational health and safety requirements when moving and lifting equipment.
- Use mechanical assistance or other suitable assistance when moving and lifting equipment.
- To reduce the weight for easier handling, remove any easily detachable components.

## Power and Electrical Warnings

**Caution:** *The power button, indicated by the stand-by power marking, DOES NOT completely turn off the system AC power; 5V standby power is active whenever the system is plugged in. To remove power from system, you must unplug the AC power cord from the wall outlet. Your system may use more than one AC power cord. Make sure all AC power cords are unplugged. Make sure the AC power cord(s) is/are unplugged before you open the chassis, or add or remove any non hot-plug components.*

*Do not attempt to modify or use an AC power cord if it is not the exact type required. A separate AC cord is required for each system power supply.*

*Some power supplies in Intel® servers use Neutral Pole Fusing. To avoid risk of shock use caution when working with power supplies that use Neutral Pole Fusing.*

*The power supply in this product contains no user-serviceable parts. Do not open the power supply. Hazardous voltage, current and energy levels are present inside the power supply. Return to manufacturer for servicing.*

*When replacing a hot-plug power supply, unplug the power cord to the power supply being replaced before removing it from the server.*

*To avoid risk of electric shock, turn off the server and disconnect the power cord, telecommunications systems, networks, and modems attached to the server before opening it.*

## Power Cord Warnings

If an AC power cord was not provided with your product, purchase one that is approved for use in your country.

**Caution:** *To avoid electrical shock or fire, check the power cord(s) that will be used with the product as follows:*

- *Do not attempt to modify or use the AC power cord(s) if they are not the exact type required to fit into the grounded electrical outlets*
- *The power cord(s) must meet the following criteria:*
- *The power cord must have an electrical rating that is greater than that of the electrical current rating marked on the product.*
- *The power cord must have safety ground pin or contact that is suitable for the electrical outlet.*
- *The power supply cord(s) is/are the main disconnect device to AC power. The socket outlet(s) must be near the equipment and readily accessible for disconnection.*
- *The power supply cord(s) must be plugged into socket-outlet(s) that is /are provided with a suitable earth ground.*

## System Access Warnings

**Caution:** To avoid personal injury or property damage, the following safety instructions apply whenever accessing the inside of the product:

- Turn off all peripheral devices connected to this product.
- Turn off the system by pressing the power button to off.
- Disconnect the AC power by unplugging all AC power cords from the system or wall outlet.
- Disconnect all cables and telecommunication lines that are connected to the system.
- Retain all screws or other fasteners when removing access cover(s). Upon completion of accessing inside the product, refasten access cover with original screws or fasteners.
- Do not access the inside of the power supply. There are no serviceable parts in the power supply. Return to manufacturer for servicing.
- Power down the server and disconnect all power cords before adding or replacing any non hot-plug component.
- When replacing a hot-plug power supply, unplug the power cord to the power supply being replaced before removing the power supply from the server.

**Caution:** If the server has been running, any installed processor(s) and heat sink(s) may be hot. Unless you are adding or removing a hot-plug component, allow the system to cool before opening the covers. To avoid the possibility of coming into contact with hot component(s) during a hot-plug installation, be careful when removing or installing the hot-plug component(s).

**Caution:** To avoid injury do not contact moving fan blades. If your system is supplied with a guard over the fan, do not operate the system without the fan guard in place.

## Rack Mount Warnings

The equipment rack must be anchored to an unmovable support to prevent it from tipping when a server or piece of equipment is extended from it. The equipment rack must be installed according to the rack manufacturer's instructions.

Install equipment in the rack from the bottom up, with the heaviest equipment at the bottom of the rack.

Extend only one piece of equipment from the rack at a time.

You are responsible for installing a main power disconnect for the entire rack unit. This main disconnect must be readily accessible, and it must be labeled as controlling power to the entire unit, not just to the server(s).

To avoid risk of potential electric shock, a proper safety ground must be implemented for the rack and each piece of equipment installed in it.



## Electrostatic Discharge (ESD)

**Caution:** ESD can damage disk drives, boards, and other parts. We recommend that you perform all procedures at an ESD workstation. If one is not available, provide some ESD protection by wearing an antistatic wrist strap attached to chassis ground -- any unpainted metal surface -- on your server when handling parts.

Always handle boards carefully. They can be extremely sensitive to ESD. Hold boards only by their edges. After removing a board from its protective wrapper or from the server, place the board component side up on a grounded, static free surface. Use a conductive foam pad if available but not the board wrapper. Do not slide board over any surface.

## Other Hazards

### Battery Replacement

**Caution:** There is the danger of explosion if the battery is incorrectly replaced. When replacing the battery, use only the battery recommended by the equipment manufacturer.

Dispose of batteries according to local ordinances and regulations.

Do not attempt to recharge a battery.

Do not attempt to disassemble, puncture, or otherwise damage a battery.

### Cooling and Airflow

**Caution:** Carefully route cables as directed to minimize airflow blockage and cooling problems.

For proper cooling and airflow, operate the system only with the chassis covers installed. Operating the system without the covers in place can damage system parts. To install the covers:

- Check first to make sure you have not left loose tools or parts inside the system.
- Check that cables, add-in boards, and other components are properly installed.
- Attach the covers to the chassis according to the product instructions.

### Laser Peripherals or Devices

**Caution:** To avoid risk of radiation exposure and/or personal injury:

- Do not open the enclosure of any laser peripheral or device
- Laser peripherals or devices have are not user serviceable
- Return to manufacturer for servicing

# Deutsch

## Sicherheitshinweise für den Server

Das vorliegende Dokument bezieht sich auf Intel® Serverplatinen, Intel® Servergehäuse (Standfuß und Rack) sowie installierte Peripheriegeräte. Es enthält Warnungen und Vorsichtsmaßnahmen zur Vermeidung von Gefahren durch Verletzung, Stromschlag, Feuer und Beschädigungen von Geräten. Lesen Sie diese Dokument daher sorgfältig, bevor Sie Ihr Intel® Serverprodukt installieren oder warten.



Bei Widersprüchen zwischen den hier vorliegenden Angaben und den Informationen im Lieferumfang des Produkts oder auf der Website des betreffenden Produkts hat die Produktdokumentation Vorrang.



Die Integration und Wartung des Servers darf nur durch technisch qualifizierte Personen erfolgen.

Um die Einhaltung der vorhandenen Zulassungen und Genehmigungen für das Produkt zu gewährleisten, sind die Richtlinien in diesem Handbuch sowie die Montageanleitungen in den Serverhandbüchern zu beachten. Verwenden Sie nur die beschriebenen, zugelassenen Komponenten, die im vorliegenden Handbuch angegeben werden. Die Verwendung anderer Produkte oder Komponenten führt zum Erlöschen der UL-Zulassung und anderer Genehmigungen für das Produkt. Dadurch kann das Produkt gegen Produktbestimmungen verstoßen, die im Verkaufsland gelten.

## Sicherheitshinweise und Vorsichtsmaßnahmen

Um Verletzungen und Beschädigungen zu vermeiden, sollten Sie vor dem Beginn der Produktinstallation die nachfolgend aufgeführten Sicherheitshinweise und -informationen sorgfältig lesen und befolgen. In dem vorliegenden Handbuch sowie auf dem Produkt und auf der Verpackung werden folgende Sicherheitssymbole verwendet:

<b>VORSICHT</b>	Weist auf eine Gefahrenquelle hin, die bei Nichtbeachtung des VORSICHTSHINWEISES zu leichteren Verletzungen bzw. Sachbeschädigungen führen kann.
<b>WARNUNG</b>	Weist auf eine Gefahrenquelle hin, die bei Nichtbeachtung der WARNUNG zu ernstesten Verletzungen führen kann.
	Weist auf potentielle Gefahr bei Nichtbeachtung der angezeigten Informationen hin.
	Weist auf die Gefahr eines Stromschlags hin, der bei Nichtbeachtung der Sicherheitshinweise zu schweren oder tödlichen Verletzungen führen kann.
	Weist auf Verbrennungsgefahr an heißen Bauteilen bzw. Oberflächen hin.

	Weist darauf hin, daß das Anfassen des Gebläses zu Verletzungen führen kann.
	Bedeutet, alle Netzkabel abzuziehen und das Gerät von der Netzspannung zu trennen.
	Bereiten Sie bitte Batterie auf

## Zielbenutzer der Anwendung

Dieses Produkt wurde in seiner Eigenschaft als IT-Gerät getestet, das in Büros, Schulen, Computerräumen und ähnlichen öffentlichen Räumlichkeiten installiert werden kann. Die Eignung dieses Produkts für andere Einsatzbereiche als IT (z. B. Medizin, Industrie, Alarmsysteme oder Prüfgeräte) kann u. U. weitere Tests erfordern.

## Standortauswahl

Das System ist für den Betrieb innerhalb normaler Büroumgebungen geeignet. Wählen Sie einen Standort, der folgenden Kriterien entspricht:

- Sauber, trocken und frei von Partikeln in der Luft (außer dem normalen Raumstaub).
- Gut belüftet, nicht in der Nähe von Wärmequellen und keiner direkten Sonnenbestrahlung ausgesetzt.
- Nicht in der Nähe von Vibrations- oder Erschütterungsquellen.
- Abgeschirmt von starken elektromagnetischen Feldern, die durch elektrische Geräte erzeugt werden.
- In gewittergefährdeten Gebieten sollten Sie das System an einen Überspannungsschutz anschließen und bei einem Gewitter die Telekommunikationskabel zum Modem abziehen.
- Eine ordnungsgemäß geerdete Wandsteckdose muß vorhanden sein.
- Ausreichender Freiraum für den Zugang zu den Netzkabeln, da diese die Hauptvorrichtung zum Trennen des Produkts von der Stromversorgung sind.

## Handhabung von Geräten

Beachten Sie zur Vermeidung von Verletzungen oder Beschädigungen an den Geräten die folgenden Hinweise:

- Halten Sie beim Transportieren und Anheben von Geräten die örtlichen Gesundheits- und Sicherheitsvorschriften ein.
- Verwenden Sie mechanische oder andere geeignete Hilfsmittel zum Transportieren oder Anheben von Geräten.
- Entfernen Sie alle Komponenten, die sich leicht abnehmen lassen, um das Gewicht zu reduzieren und die Handhabung zu erleichtern.

## Warnungen zu Netzspannung und Elektrizität

**Caution:** Durch Betätigen der mit dem Standby-Symbol gekennzeichneten Netztaste wird das System NICHT vollständig vom Netz getrennt. Es sind weiterhin 5 V aktiv, solange das System eingesteckt ist. Um das System vollständig vom Strom zu trennen, muß das Netzkabel aus der Steckdose abgezogen werden. Das System verfügt möglicherweise über mehrere Netzkabel. Vergewissern Sie sich in diesem Fall, daß alle Netzkabel abgezogen sind. Wenn Sie Komponenten ein- oder ausbauen möchten, die nicht hot-plug-fähig sind, stellen Sie sicher, daß zuvor alle Netzkabel abgezogen sind.

Nehmen Sie keine Änderungen am Netzkabel vor, und verwenden Sie kein Kabel, das nicht genau dem geforderten Typ entspricht. Jedes Netzteil im System muß über ein eigenes Netzkabel angeschlossen werden.

Einige Netzteile von Intel Servern verwenden Nullleitersicherungen. Vorsicht ist geboten im Umgang mit Netzteilen, welche Nullleitersicherungen verwenden, um das Risiko eines elektrischen Schlages zu vermeiden

Das Netzteil in diesem Produkt enthält keine Teile, die vom Benutzer gewartet werden können. Öffnen Sie das Netzteil nicht. Im Netzteil bestehen gefährliche Spannungen, Ströme und Energiequellen. Schicken Sie das Gerät für Wartungsarbeiten an den Hersteller zurück.

Wenn Sie ein hot-plug-fähiges Netzteil austauschen, ziehen Sie dessen Netzkabel ab, bevor Sie es aus dem Server ausbauen.

Zur Vermeidung von Stromschlägen schalten Sie den Server aus, und trennen Sie vor dem Öffnen des Geräts das Netzkabel sowie alle an den Server angeschlossene Telekommunikationssysteme, Netzwerke und Modems.

## Hinweis für Netzkabel

Wenn kein Netzkabel mit dem Produkt geliefert wurde, kaufen Sie ein Kabel, das für die

**Caution:** Prüfen Sie zur Vermeidung von Stromschlag oder Feuergefahr die mit dem Produkt zu verwendenden Netzkabel wie folgt:

- Nehmen Sie keine Änderungen an einem Netzkabel vor, und benutzen sie es nicht, wenn es nicht genau in die geerdeten Netzsteckdosen paßt.
- Netzkabel müssen die folgenden Anforderungen erfüllen:
  - Die Nennbelastbarkeit des Netzkabels muß mindestens so hoch sein wie die am Produkt angegebenen Nennstromaufnahme.
  - Das Netzkabel muß einen zur Netzsteckdose passenden Schutzkontakt besitzen.
- Die Netzkabel sind die Hauptvorrichtung zum Trennen des Geräts vom Stromnetz. Die Steckdose muß in der Nähe der Anlage angebracht und gut erreichbar sein.
- Netzkabel müssen an eine ordnungsgemäß geerdete Steckdose angeschlossen sein.

## Warnhinweise für den Systemzugang

**Caution:** Um Verletzungen und Beschädigungen zu vermeiden, sollten Sie vor Arbeiten im Produktinneren folgende Sicherheitsanweisungen beachten:

- Schalten Sie alle am Produkt angeschlossenen Peripheriegeräte aus.
- Schalten Sie das System mit dem Netzschalter aus.
- Trennen Sie das Gerät von der Stromquelle, indem Sie alle Netzkabel vom System bzw. aus der Steckdose ziehen.
- Ziehen Sie alle Kabel und alle an das System angeschlossenen Telekommunikationsleitungen ab.
- Bewahren Sie alle Schrauben und anderen Befestigungselemente gut auf, nachdem Sie die Gehäuseabdeckung entfernt haben. Wenn Sie Ihre Arbeiten im Systeminneren beendet haben, befestigen Sie die Gehäuseabdeckung mit den Originalschrauben bzw. -befestigungselementen.
- Führen Sie keine Arbeiten im Netzteil aus. Das Netzteil enthält keine für den Benutzer wartungsbedürftigen Teile. Schicken Sie das Gerät für Wartungsarbeiten an den Hersteller zurück.
- Schalten Sie den Server aus, und ziehen Sie alle Netzkabel ab, bevor Sie Komponenten ein- oder ausbauen, die nicht hot-plug-fähig sind.
- Wenn Sie ein hot-plug-fähiges Netzteil austauschen, ziehen Sie dessen Netzkabel ab, bevor Sie es aus dem Server ausbauen.

**Caution:** War Ihr Server in Betrieb, können die installierten Prozessoren und Kühlkörper heiß sein. Sofern Sie keine Hot-Plug-Komponenten ein- oder ausbauen, warten Sie mit dem Abnehmen der Abdeckungen, bis das System abgekühlt ist. Gehen Sie beim Aus- oder Einbauen von Hot-Plug-Komponenten sorgfältig vor, um nicht mit heißen Komponenten in Berührung zu kommen.

**Caution:** Berühren Sie nicht die rotierenden Lüfterflügel, um Verletzungen zu vermeiden. Falls Ihr System mit einer Lüfterabdeckung besitzt, darf es nicht ohne diese Abdeckung betrieben werden.

## Warnhinweise für Racks

Das Geräte-Rack muß auf einer geeigneten, festen Unterlage verankert werden, um ein Umkippen zu vermeiden, wenn ein Server oder andere Geräte herausgezogen werden. Bei der Installation des Racks müssen die Anweisungen des Rack-Herstellers beachtet werden.

Gehen Sie bei der Installation von Geräten im Rack immer von unten nach oben vor, und bauen Sie das schwerste Gerät an der untersten Position im Rack ein.

Ziehen Sie jeweils immer nur ein Gerät aus dem Rack heraus.

Sie müssen für die gesamte Rack-Einheit einen Netztrennschalter einrichten. Dieser Netztrennschalter muß leicht zugänglich sein und über eine Kennzeichnung verfügen, die besagt, daß er die Stromzufuhr zur gesamten Einheit steuert und nicht nur zu den Servern.

Zur Vermeidung von Stromschlaggefahr müssen das Rack selbst und alle darin eingebauten Geräte ordnungsgemäß geerdet sein.

## Elektrostatische Entladungen (ESD)

**Caution:** *Elektrostatische Entladungen können zur Beschädigung von Festplatten, Platinen und anderen Komponenten führen. Daher sollten Sie alle Arbeiten an einer ESD-Workstation ausführen. Steht ein solcher Arbeitsplatz nicht zur Verfügung, erzielen Sie einen gewissen Schutz vor elektrostatischen Entladungen durch Tragen einer Antistatik-Manschette, die Sie während der Arbeit zur Erdung an einem beliebigen unlackierten Metallteil des Computergehäuses befestigen.*

*Gehen Sie bei der Handhabung von Platinen immer mit größter Vorsicht vor. Sie können äußerst empfindlich gegenüber elektrostatischer Entladung sein. Halten Sie Platinen nur an den Kanten fest. Legen Sie die Platinen nach dem Auspacken aus der Schutzhülle oder nach dem Ausbau aus dem Server mit der Bauelementseite nach oben auf eine geerdete, statisch entladene Unterlage. Verwenden Sie dazu, sofern verfügbar, eine leitfähige Schaumstoffunterlage, aber nicht die Schutzhülle der Platine. Ziehen Sie die Platine nicht über eine Fläche.*

## Andere Gefahren

### Batterieaustausch

**Caution:** *Wird die Batterie unsachgemäß ausgetauscht, besteht Explosionsgefahr. Verwenden Sie als Ersatz nur die vom Gerätehersteller empfohlene Batterie.*

*Beachten Sie bei der Entsorgung von Batterien die gültigen Bestimmungen.*

*Versuchen Sie nicht, eine Batterie aufzuladen.*

*Versuchen Sie nicht, eine Batterie zu öffnen oder sonstwie zu beschädigen.*

### Kühlung und Luftstrom

**Caution:** *Verlegen Sie Kabel sorgfältig entsprechend der Anleitung, um Störungen des Luftstroms und Kühlungsprobleme zu vermeiden.*

Zur Gewährleistung des ordnungsgemäßen Kühlungs- und Luftstromverhaltens darf das System nur mit angebrachten Gehäuseabdeckungen betrieben werden. Die Inbetriebnahme des Systems ohne Abdeckung kann zur Beschädigung von Systemkomponenten führen. So bringen Sie die Abdeckung wieder an:

- Vergewissern Sie sich zunächst, daß Sie keine Werkzeuge oder Teile im Gehäuse vergessen haben.

- Vérifiez si les câbles, les cartes d'extension et les autres composants sont correctement installés.
- Fixez les couvercles du boîtier du produit, comme décrit dans le manuel d'installation.

## Laser-Peripheralgeräte oder -Komponenten

**Caution:** Beachten Sie zur Vermeidung von Strahlung und Verletzungen die folgenden Hinweise:

- Öffnen Sie keinesfalls das Gehäuse von Laser-Peripheralgeräten oder Laser-Komponenten.
- Laser-Peripheralgeräte oder -Komponenten besitzen keine für den Benutzer wartungsbedürftigen Teile.
- Schicken Sie das Gerät für Wartungsarbeiten an den Hersteller zurück.

## Français

### Consignes de sécurité sur le serveur

Ce document s'applique aux cartes serveur Intel<sup>®</sup>, au châssis de serveur Intel<sup>®</sup> (sur pieds et sur rack) et aux périphériques installés. Pour réduire les risques de dommages corporels, d'électrocution, d'incendie et de dommages matériels, lisez ce document et respectez tous les avertissements et précautions mentionnés dans ce guide avant d'installer ou de mettre à jour votre produit serveur Intel<sup>®</sup>.







En cas de conflit entre les informations fournies dans ce document et celles livrées avec le produit ou publiées sur le site Web pour un produit particulier, la documentation du produit prime.

Votre serveur doit être intégré et entretenu uniquement par des techniciens qualifiés.

Vous devez suivre les informations de ce guide et les instructions d'assemblage des manuels de serveur pour vérifier et maintenir la conformité avec les certifications et approbations de produit existantes. Utilisez uniquement les composants décrits et réglementés spécifiés dans ce guide. L'utilisation d'autres produits/composants annulera la liste UL et les autres approbations réglementaires du produit, et le produit peut ne pas être conforme aux autres lois et réglementations locales applicables au produit.

### Sécurité: avertissements et mises en garde

Pour éviter de vous blesser ou d'endommager votre équipement, lisez et respectez toutes les informations et consignes de sécurité avant de commencer l'installation du produit. Les symboles de sécurité suivants peuvent être utilisés tout au long de cette documentation et peuvent figurer sur le produit ou sur son emballage.

<b>ATTENTION</b>	Indique la présence d'un risque pouvant entraîner des blessures physiques mineures ou endommager légèrement le matériel si la mise en garde n'est pas prise en compte.
<b>AVERTISSEMENT</b>	Indique la présence d'un risque pouvant entraîner des blessures corporelles graves si l'avertissement n'est pas pris en compte.
	Indique un risque potentiel si les informations signalées ne sont pas prises en compte.
	Indique des risques d'électrocution pouvant entraîner des blessures corporelles graves ou mortelles si les consignes de sécurité ne sont pas respectées.
	Signale des composants ou des surfaces soumis à des températures élevées.
	Indique de ne pas toucher aux pales de ventilateur, car cela peut entraîner des blessures.
	Indique de débrancher tous les cordons d'alimentation secteur pour déconnecter l'alimentation.
	Veillez réutiliser la batterie

## Domaines d'utilisation prévus

Ce produit a été testé comme équipement informatique (ITE) et peut être installé dans des bureaux, des écoles, des salles informatiques et des endroits commerciaux similaires. L'utilisation du présent produit dans des catégories et environnements de produits et domaines d'application (par exemple, le domaine médical, industriel, résidentiel, les systèmes d'alarme et les appareils de contrôle) autres qu'ITE doit faire l'objet d'évaluations supplémentaires.

## Sélection d'un emplacement

Le système est conçu pour fonctionner dans un environnement standard de bureau. Choisissez un emplacement respectant les conditions suivantes :

- Propre, sec et exempt de particules en suspension (autres que la poussière normale d'une pièce).
- Bien ventilé et à l'écart des sources de chaleur telles que la lumière directe du soleil et les radiateurs.
- À l'écart des sources de vibration ou des chocs physiques.
- Isolé des champs électromagnétiques importants produits par des appareils électriques.



- Dans les régions sujettes aux orages magnétiques, nous vous recommandons de brancher votre système à un suppresseur de surtension et de déconnecter les lignes de télécommunication de votre modem pendant les orages.
- Équipé d'une prise murale reliée à la terre.
- Équipé d'un espace suffisant pour accéder aux cordons d'alimentation secteur, car ils servent de disjoncteur principal d'alimentation du produit.

## Pratiques de manipulation de l'équipement

Réduisez le risque de dommages personnels ou matériels :

- Conformez-vous aux exigences de médecine du travail et de sécurité lorsque vous déplacez et soulevez le matériel.
- Utilisez l'assistance mécanique ou toute autre assistance appropriée lorsque vous déplacez et soulevez le matériel.
- Pour réduire le poids en vue de faciliter la manipulation, retirez tout composant amovible.

## Alimentation et avertissements en matière d'électricité

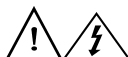

**Attention:** Le bouton d'alimentation, indiqué par le symbole de mise en veille, NE COUPE PAS complètement l'alimentation secteur du système car le courant de veille 5 V reste actif lorsque le système est sous tension. Pour couper l'alimentation du système, vous devez débrancher le cordon d'alimentation secteur de la prise murale. Votre système peut utiliser plusieurs cordons d'alimentation secteur. Assurez-vous que tous les cordons d'alimentation sont débranchés. Vous devez les débrancher avant d'ouvrir le châssis, d'ajouter ou de supprimer un composant non connectable à chaud.

Les alimentations de certains serveurs Intel sont munies de doubles fusibles pôle/neutre: veuillez observer les précautions d'usage afin d'éviter tout risque d'électrocution.

N'essayez pas de modifier ou d'utiliser un cordon d'alimentation secteur s'il ne s'agit pas du type exact requis. Un cordon secteur est requis pour chaque alimentation système.

Le bloc d'alimentation de ce produit ne contient aucun composant réparable par l'utilisateur. N'ouvrez pas le bloc d'alimentation. L'intérieur de celui-ci est soumis à des

niveaux dangereux de tension, de courant et d'énergie. Renvoyez-le au fabricant en cas de problème.

Lorsque vous remplacez un bloc d'alimentation à chaud, débranchez le cordon du bloc d'alimentation en cours de remplacement avant de le retirer du serveur.

Pour éviter tout risque d'électrocution, mettez le système hors tension et débranchez les cordons d'alimentation ainsi que les systèmes de télécommunication, réseaux et modems reliés au système avant d'ouvrir ce dernier.

## Avertissements sur le cordon d'alimentation

Si aucun cordon d'alimentation secteur n'a été fourni avec votre produit, vous devez vous en procurer un qui soit approuvé pour une utilisation dans votre pays.



**Attention:** Pour éviter tout risque d'électrocution ou d'incendie, vérifiez les cordons d'alimentation qui seront utilisés avec le produit comme suit :

- N'essayez pas d'utiliser ou de modifier les cordons d'alimentation en CA s'ils ne correspondent pas exactement au type requis pour les prises électriques reliées à la terre.
- Les cordons d'alimentation doivent répondre aux critères suivants :
  - Le cordon d'alimentation doit supporter une intensité supérieure à celle indiquée sur le produit.
  - Le cordon d'alimentation doit posséder une broche ou un contact de mise à la terre approprié à la prise électrique.
- Les cordons d'alimentation électrique représentent le principal dispositif de déconnexion raccordé à l'alimentation secteur. Les prises de courant doivent se trouver à proximité de l'équipement et être facilement accessibles pour une déconnexion.
- Les cordons d'alimentation doivent être branchés sur des prises électriques correctement reliées à la terre.

## Avertissements sur l'accès au système



**Attention:** Pour éviter de vous blesser ou d'endommager votre équipement, les consignes de sécurité suivantes s'appliquent chaque fois que vous accédez à l'intérieur du produit :

- Mettez hors tension tous les périphériques connectés à ce produit.
- Éteignez le système en appuyant sur le bouton d'alimentation.
- Déconnectez l'alimentation secteur en débranchant tous les cordons d'alimentation secteur du système ou de la prise murale.
- Déconnectez l'ensemble des câbles et lignes de télécommunication qui sont connectés au système.

- Mettez toutes les vis ou autres attaches de côté lorsque vous retirez les panneaux d'accès. Une fois que vous avez terminé d'accéder à l'intérieur du produit, refixez le panneau d'accès avec les vis ou attaches d'origine.
- N'essayez pas d'accéder à l'intérieur du bloc d'alimentation. Il ne contient aucune pièce réparable. Renvoyez-le au fabricant en cas de problème.
- Mettez le serveur hors tension et débranchez tous les cordons d'alimentation avant d'ajouter ou de remplacer tout composant non connectable à chaud.
- Lorsque vous remplacez le bloc d'alimentation à chaud, débranchez le cordon du bloc d'alimentation en cours de remplacement avant de retirer le bloc du serveur.



**Attention:** Si le serveur a été utilisé, les processeurs et dissipateurs de chaleur installés peuvent être chauds. À moins que vous n'ajoutiez ou ne retiriez un composant connectable à chaud, laissez le système refroidir avant d'ouvrir les panneaux. Pour éviter tout risque d'entrer en contact avec un composant chaud lors d'une installation à chaud, prenez toutes les précautions nécessaires lorsque vous retirez ou installez des composants connectables à chaud.



**Attention:** Pour éviter de vous blesser, ne touchez pas les pales de ventilateur en mouvement. Si votre système est fourni avec une protection sur le ventilateur, ne mettez pas le système en route sans la protection en place.

## Avertissements sur le montage en rack

Le rack doit être fixé à un support inamovible pour éviter qu'il ne bascule lors de l'extension d'un serveur ou d'un élément de l'équipement. Le rack doit être installé conformément aux instructions du fabricant.

Installez les équipements dans le rack en partant du bas, en plaçant le plus lourd en bas du rack.

N'étendez qu'un seul élément de l'équipement à partir du rack à la fois.

Vous êtes responsable de l'installation d'un disjoncteur principal d'alimentation pour la totalité du rack. Ce disjoncteur principal doit être rapidement accessible et doit être étiqueté comme contrôlant toute l'unité, et pas uniquement le ou les serveurs.

Pour éviter tout risque d'électrocution, le rack et chaque élément de l'équipement installé dans le rack doivent être correctement reliés à la terre.

## Décharges électrostatiques (ESD)



**Attention:** Les décharges électrostatiques (ESD) peuvent endommager les lecteurs de disque dur, les cartes et d'autres pièces. Il est fortement conseillé d'effectuer l'ensemble des procédures décrites à un poste de travail protégé contre les ESD. Au cas où aucun poste de ce type ne serait disponible, protégez-vous contre les ESD en portant un bracelet antistatique relié à la masse du châssis (n'importe quelle surface métallique non peinte) de votre serveur lorsque que vous manipulez les pièces.

Manipulez toujours les cartes avec précaution. Elles peuvent être extrêmement sensibles aux ESD. Ne tenez les cartes que par leurs bords. Après avoir retiré une carte de son emballage de protection ou du serveur, placez-la sur une surface reliée à la terre, exempte de charge statique, composants orientés vers le haut. Utilisez si possible un tapis de mousse conducteur, mais pas l'emballage de la carte. Veillez à ce que la carte ne glisse sur aucune surface.

## Autres risques

### Remplacement de la pile



**Attention:** Il existe un risque d'explosion si la pile n'est pas correctement remplacée. Lors du remplacement de la pile, utilisez uniquement celle recommandée par le fabricant du matériel.

Mettez la pile au rebut en vous conformant aux réglementations locales.

N'essayez pas de recharger une pile.

N'essayez pas de démonter, de percer ou d'endommager la pile d'une quelconque façon.

### Refroidissement et ventilation



**Attention:** Routez les câbles avec précaution comme indiqué pour minimiser les blocages de circulation d'air et les problèmes de refroidissement.

Afin de permettre une ventilation et un refroidissement corrects, ne mettez le système en marche que lorsque les panneaux du châssis sont en place. L'utilisation du système sans les panneaux peut endommager les composants système. Pour installer les panneaux :

- Vérifiez tout d'abord que vous n'avez pas oublié d'outils ou de composants détachés à l'intérieur du système.
- Vérifiez que les câbles, les cartes d'extension et les autres composants sont correctement installés.
- Fixez les panneaux au châssis en suivant les instructions du produit.

## Périphériques laser



*Attention: Pour éviter tout risque d'exposition aux rayonnements et/ou de dommage personnel:*

- *N'ouvrez pas l'enceinte d'un périphérique laser.*
- *Les périphériques laser ne sont pas réparables par l'utilisateur.*
- *Retournez-les au fabricant en cas de problème.*

## Español

### Información de seguridad del servidor

Este documento se aplica a las tarjetas de servidor de Intel®, las carcasas de servidor de Intel® (montaje en bastidor y en pedestal) y los dispositivos periféricos. Para reducir el riesgo de daños corporales, descargas eléctricas, fuego y en el equipo, lea este documento y preste atención a todos las advertencias y precauciones de esta guía antes de instalar o mantener el producto de servidor de Intel®.

En el caso de que haya diferencias entre la información para un producto en particular contenida en este documento y la información proporcionada con dicho producto o en el sitio Web, la documentación del producto es la que prevalece.







Sólo personal técnico cualificado debe montar y prestar los servicios para el servidor.

Debe ceñirse a las directrices de esta guía y a las instrucciones de montaje de los manuales del servidor para asegurar y mantener el cumplimiento con las certificaciones y homologaciones existentes de los productos. Utilice sólo los componentes descritos y homologados que se especifican en esta guía. El uso de otros productos o componentes anulará la homologación UL y otras certificaciones oficiales del producto, pudiendo dejar de ser compatible con las normativas locales de los países en los que se comercializa.

### Advertencias y precauciones sobre seguridad

Para reducir la posibilidad de que se produzcan lesiones personales o daños en la propiedad, antes de empezar a instalar el producto, lea, observe y cumpla toda la información e instrucciones de seguridad siguientes. Puede que se utilicen los siguientes símbolos de seguridad en la documentación y es posible que aparezcan en el producto o en su embalaje.

<b>PRECAUCIÓN</b>	Indica la existencia de un riesgo que podría causar lesiones personales o daños en la propiedad leves si no se tiene en cuenta la PRECAUCIÓN.
<b>ADVERTENCIA</b>	Indica la existencia de un riesgo que podría causar lesiones personales graves si no se tiene en cuenta la ADVERTENCIA.

	Indica un riesgo potencial si no se tiene en cuenta la información indicada.
	Indica riesgo de descargas eléctricas que podrían causar lesiones graves o la muerte si no se siguen las instrucciones de seguridad.
	Indica componentes o superficies calientes.
	Indica que no se deben tocar las aspas de los ventiladores, ya que de lo contrario se podrían producir lesiones.
	Indica que es necesario desenchufar los cables de alimentación de CA para desconectar la alimentación de CA
	Recicle por favor la batería

## Aplicaciones y usos previstos

Este producto ha sido evaluado como equipo de tecnología informática (ITE) que puede instalarse en oficinas, escuelas, salas de equipos informáticos o lugares de ámbito comercial similares. Es posible que sea necesario llevar a cabo una evaluación adicional para comprobar si este producto es apropiado para otras categorías de productos y entornos además de las aplicaciones informáticas (por ejemplo, soluciones médicas, industriales, residenciales, sistemas de alarma y equipos de pruebas).

## Selección de la ubicación

El sistema se ha diseñado para funcionar en un entorno normal de oficinas. Seleccione una ubicación que esté:

- Limpia, seca y libre de macropartículas en suspensión en el aire (que no sean el polvo habitual de la habitación).
- Bien ventilada y alejada de fuentes de calor, incluida la luz solar directa y los radiadores.
- Alejada de fuentes de vibración o de golpes físicos.
- Aislada de campos electromagnéticos producidos por dispositivos eléctricos.
- En zonas propensas a tormentas eléctricas, se recomienda que conecte el servidor a un supresor de sobretensiones y desconecte las líneas de telecomunicaciones al módem durante una tormenta eléctrica.
- Provista de una toma de corriente alterna correctamente conectada a tierra.
- Provista de espacio suficiente para acceder a los cables de la fuente de alimentación ya que constituyen la desconexión principal de la alimentación.

## Manipulación del equipo

Reduzca el riesgo de daños personales o en el equipo:

- Respete los requisitos de sanidad y seguridad laborales de su país cuando traslade y levante el equipo.
- Utilice medios mecánicos u otros que sean adecuados al trasladar o levantar el equipo.
- Para que el peso sea menor para manipularlo con más facilidad, extraiga los componentes que sean de fácil extracción.

## Advertencias de alimentación y eléctricas



*Precaución: El botón de encendido, indicado con la marca del modo de reposo o stand-by, NO DESCONECTA completamente la alimentación de CA del sistema, ya que el modo de reposo de 5 V sigue activo mientras el sistema está enchufado. Para desconectar el sistema debe desenchufar el cable de alimentación de CA de la toma de la pared. Puede usar más de un cable de alimentación de CA con el sistema. Asegúrese de que todos los cables de alimentación de CA están desenchufados. Asegúrese de que los cables de alimentación de CA estén desenchufado antes de abrir la carcasa, agregar o extraer cualquier componente que no es de conexión en funcionamiento.*

*Algunas fuentes de alimentación de electricidad de los servidores de Intel utilizan el polo neutral del fuselaje. Para evitar riesgos de choques eléctricos use precauciones al trabajar con las fuentes de alimentación que utilizan el polo neutral de fuselaje.*

*No intente modificar ni utilizar un cable de alimentación de CA si no es del tipo exacto requerido. Se necesita un cable de CA para cada fuente de alimentación del sistema.*

*La fuente de alimentación de este producto no contiene piezas que puedan ser reparadas por el usuario. No abra la fuente de alimentación. Dentro de la fuente de alimentación puede haber niveles de tensión, corriente y energía peligrosos. Devuélvala al fabricante para repararla.*

*Al reemplazar una fuente de alimentación de conexión en funcionamiento, desenchufe el cable de alimentación de la fuente de alimentación que va a reemplazar antes de extraerla del servidor.*

*Para evitar el riesgo de descargas eléctricas, antes de abrir el servidor, apáguelo, desconecte el cable de alimentación, los sistemas de telecomunicaciones, las redes y los módems conectados al mismo.*

## Advertencias sobre el cable de alimentación

Si no se ha proporcionado con el producto ningún cable de alimentación de CA, adquiera alguno cuyo uso esté aprobado en su país.



*Precaución: Para evitar descargas eléctricas o fuego, revise los cables de alimentación que usará con el producto tal y como se describe a continuación:*

- *No intente modificar ni utilizar los cables de alimentación de CA si no son exactamente del modelo especificado para ajustarse a las tomas de corriente conectadas a tierra.*
- *Los cables de alimentación deben reunir los siguientes requisitos:*
  - *El cable de alimentación debe disponer de una capacidad nominal de corriente eléctrica mayor que la capacidad especificada en el producto.*
  - *El cable de alimentación debe disponer de una patilla o contacto de conexión a tierra que sea apto para la toma de corriente.*
- *Los cables de la fuente de alimentación son los dispositivos de desconexión principales a la corriente alterna. El enchufe o enchufes de zócalo deben encontrarse cerca del equipo y el acceso a ellos debe poderse efectuar de forma inmediata con el fin de desconectarlos.*
- *Los cables de la fuente de alimentación deben estar conectados a los enchufes con una toma de tierra adecuada.*

## **Advertencias el acceso al sistema**



*Precaución: Para evitar lesiones personales o daños en la propiedad, se aplican las siguientes instrucciones de seguridad siempre que se acceda al interior del producto:*

- *Apague todos los dispositivos periféricos conectados a este producto.*
- *Pulse el botón de alimentación para apagar el sistema.*
- *Desconecte la alimentación de CA desenchufando los cables de alimentación de CA del sistema o de la toma de corriente alterna.*
- *Desconecte todos los cables y líneas de telecomunicación que estén conectados al sistema.*
- *Guarde todos los tornillos o elementos de fijación cuando retire las cubiertas de acceso. Cuando termine de operar en el interior del producto, vuelva a colocar los tornillos o los elementos de fijación originales de la cubierta de acceso.*
- *No acceda al interior de la fuente de alimentación. No hay elementos en la fuente de alimentación que usted pueda reparar y utilizar. Devuélvala al fabricante para repararla.*
- *Apague el servidor y desconecte todos los cables de alimentación antes de agregar o reemplazar cualquier componente que no es de conexión en funcionamiento.*



- *Al reemplazar una fuente de alimentación de conexión en funcionamiento, desenchufe el cable de alimentación de la fuente de alimentación que va a reemplazar antes de extraerla del servidor.*



*Precaución: Si el servidor se ha estado ejecutando, los procesadores y disipadores de calor estarán recalentados. A no ser que esté instalando o extrayendo un componente de conexión en funcionamiento, deje que el sistema se enfríe antes de abrir las cubiertas. Para que no llegue a tocar los componentes que estén calientes cuando esté realizando una instalación de conexión en funcionamiento, tenga cuidado al extraer o instalar los componentes de conexión en funcionamiento.*



*Precaución: Para evitar posibles daños, no toque las aspas en movimiento de los ventiladores. Si el sistema se le ha suministrado con una protección para el ventilador, asegúrese de que cuando esté funcionando el sistema la protección esté en su sitio.*

## Advertencias sobre el montaje en bastidor

El bastidor del equipo se debe sujetar con un soporte fijo para evitar que se caiga cuando se extraiga un servidor o una pieza del mismo. El bastidor del equipo debe instalarse siguiendo las instrucciones del fabricante del bastidor.

Instale el equipo en el bastidor comenzando desde la parte de abajo, con el equipo más pesado en la parte inferior del bastidor.

Extraiga las piezas del equipo del bastidor de una a una.

El usuario es el responsable de la instalación de un dispositivo de desconexión de la alimentación principal para toda la unidad del bastidor. El acceso a este dispositivo de desconexión deberá ser de fácil acceso y deberán incluirse indicaciones que lo identifiquen como el control de alimentación eléctrica de toda la unidad, no sólo de los servidores.

Para evitar el riesgo de descargas eléctricas, deberá instalar una conexión a tierra apropiada para el bastidor y para cada pieza del equipo instalada en el mismo.

## Descarga electrostática (ESD)



*Precaución: Las descargas electrostáticas pueden dañar las unidades de disco, las tarjetas y otros componentes. Recomendamos que realice todos los procedimientos en una estación de trabajo protegida contra descargas electrostáticas. En caso de que no haya una*

*disponible, protéjase de alguna forma contras las descargas llevando un brazalete antiestático conectado a la toma de tierra de la carcasa (cualquier superficie de metal que no esté pintada) del servidor cuando manipule las piezas.*

*Manipule siempre las tarjetas con el máximo cuidado. Pueden ser sumamente sensibles a las descargas electrostáticas. Sujételas sólo por los bordes. Una vez extraída la tarjeta de su envoltorio de protección o del servidor, colóquela con el lado de los componentes hacia arriba sobre una superficie con toma de tierra y sin carga estática. Utilice una almohadilla de espuma conductora si dispone de ella, pero nunca el envoltorio de la tarjeta. No deslice la tarjeta sobre ninguna superficie.*

## Otros riesgos

### Sustitución de la batería



*Precaución: Existe el peligro de explosión si la batería no se reemplaza correctamente. Al reemplazar la batería, utilice sólo la batería recomendada por el fabricante del equipo.*

*Deseche las baterías respetando la normativa local.*

*No intente recargar la batería.*

*No intente desmontar, pinchar o causar cualquier otro desperfecto a una batería.*

### Enfriamiento y circulación de aire

*Precaución: El tendido de los cables debe realizarse cuidadosamente tal y como se le indica para reducir al mínimo los problemas de obstrucción de la ventilación y de refrigeración.*

*Para conseguir una refrigeración y corriente de aire adecuadas, compruebe que cuando sistema esté funcionando, las cubiertas de la carcasa están instaladas. Si utiliza el sistema sin las cubiertas, podría dañar sus componentes. Para instalar las cubiertas:*

- Compruebe primero que no ha dejado herramientas o piezas sueltas dentro del sistema.*
- Compruebe que los cables, tarjetas adicionales y otros componentes están instalados correctamente.*
- Sujete las cubiertas a la carcasa siguiendo las instrucciones del producto.*

## Periféricos o dispositivos láser



*Precaución* Para evitar el riesgo de la exposición a radiaciones o de daños personales:

- *No abra la caja de ningún periférico o dispositivo láser*
- *Los periféricos o dispositivos láser no pueden ser reparados por el usuario*
- *Haga que el fabricante los repare*

