

Intel[®] Server Chassis H2000 Family Service Guide

A Guide for Technically Qualified Assemblers of Intel[®] Identified Subassemblies/Products

Order Number: G59060-004

Disclaimer

Disclaimer

Information in this document is provided in connection with Intel® products. No license, express or implied, by estoppel or otherwise, to any intellectual property rights is granted by this document. Except as provided in Intel®'s Terms and Conditions of Sale for such products, Intel® assumes no liability whatsoever, and Intel® disclaims any express or implied warranty, relating to sale and/or use of Intel® products including liability or warranties relating to fitness for a particular purpose, merchantability, or infringement of any patent, copyright or other intellectual property right. Intel® products are not designed, intended or authorized for use in any medical, life saving, or life sustaining applications or for any other application in which the failure of the Intel® product could create a situation where personal injury or death may occur. Intel® may make changes to specifications and product descriptions at any time, without notice.

Intel® server boards contain a number of high-density VLSI and power delivery components that need adequate airflow for cooling. Intel®'s own chassis are designed and tested to meet the intended thermal requirements of these components when the fully integrated system is used together. It is the responsibility of the system integrator that chooses not to use Intel® developed server building blocks to consult vendor datasheets and operating parameters to determine the amount of airflow required for their specific application and environmental conditions. Intel Corporation cannot be held responsible if components fail or the server board does not operate correctly when used outside any of their published operating or non-operating limits.

Intel, Intel Pentium, and Intel Xeon are trademarks or registered trademarks of Intel Corporation or its subsidiaries in the United States and other countries.

* Other names and brands may be claimed as the property of others.

Copyright © 2013 Intel Corporation. All Rights Reserved.

Safety Information

Important Safety Instructions

Read all caution and safety statements in this document before performing any of the instructions. See also *Intel® Server Boards and Server Chassis Safety Information* on the Intel® Server Deployment Toolkit 3.0 CD and/or at <http://www.intel.com/support/motherboards/server/sb/cs-010770.htm>.

Wichtige Sicherheitshinweise

Lesen Sie zunächst sämtliche Warnung und Sicherheitshinweise in diesem Dokument, bevor Sie eine der Anweisungen ausführen. Beachten Sie hierzu auch die Sicherheitshinweise zu Intel®-Serverplatinen und Servergehäusen auf der Intel® Server Deployment Toolkit 3.0 CD oder unter <http://www.intel.com/support/motherboards/server/sb/cs-010770.htm>.

Consignes de sécurité

Lisez attention toutes les consignes de sécurité et les mises en garde indiquées dans ce document avant de suivre toute instruction. Consultez *Intel® Server Boards and Server Chassis Safety Information* sur le Intel® Server Deployment Toolkit 3.0 CD ou bien rendez-vous sur le site <http://www.intel.com/support/motherboards/server/sb/cs-010770.htm>.

Instrucciones de seguridad importantes

Lea todas las declaraciones de seguridad y precaución de este documento antes de realizar cualquiera de las instrucciones. Vea *Intel® Server Boards and Server Chassis Safety Information* en el Intel® Server Deployment Toolkit 3.0 CD y/o en <http://www.intel.com/support/motherboards/server/sb/cs-010770.htm>.

重要安全指导

在执行任何指令之前，请阅读本文档中的所有注意事项及安全声明。和/或 <http://www.intel.com/support/motherboards/server/sb/cs-010770.htm> 上的 *Intel® Server Boards and Server Chassis Safety Information*（《Intel® 服务器主板与服务器机箱安全信息》）。

Warnings

Heed safety instructions: Before working with your server product, whether you are using this guide or any other resource as a reference, pay close attention to the safety instructions. You must adhere to the assembly instructions in this guide to ensure and maintain compliance with existing product certifications and approvals. Use only the described, regulated components specified in this guide. Use of other products/components will void the UL listing and other regulatory approvals of the product and will most likely result in noncompliance with product regulations in the region(s) in which the product is sold.

System power on/off: The power button DOES NOT turn off the system AC power. To remove power from the system, you must unplug the AC power cord from the wall outlet. Make sure the AC power cord is unplugged before you open the chassis, add, or remove any components.

Hazardous conditions, devices and cables: Hazardous electrical conditions may be present on power, telephone, and communication cables. Turn off the server and disconnect the power cord, telecommunications systems, networks, and modems attached to the server before opening it. Otherwise, personal injury or equipment damage can result.

Electrostatic discharge (ESD) and ESD protection: ESD can damage disk drives, boards, and other parts. We recommend that you perform all procedures in this chapter only at an ESD workstation. If one is not available, provide some ESD protection by wearing an antistatic wrist strap attached to chassis ground—any unpainted metal surface—on your server when handling parts.

ESD and handling boards: Always handle boards carefully. They can be extremely sensitive to ESD. Hold boards only by their edges. After removing a board from its protective wrapper or from the server, place the board component side up on a grounded, static free surface. Use a conductive foam pad if available but not the board wrapper. Do not slide board over any surface.

Installing or removing jumpers: A jumper is a small plastic encased conductor that slips over two jumper pins. Some jumpers have a small tab on top that you can grip with your fingertips or with a pair of fine needle nosed pliers. If your jumpers do not have such a tab, take care when using needle nosed pliers to remove or install a jumper; grip the narrow sides of the jumper with the pliers, never the wide sides. Gripping the wide sides can damage the contacts inside the jumper, causing intermittent problems with the function controlled by that jumper. Take care to grip with, but not squeeze, the pliers or other tool you use to remove a jumper, or you may bend or break the pins on the board.

Preface

About this Manual

This manual is written for system technicians who are responsible for troubleshooting, upgrading, and repairing this server system. This document provides a brief overview of the features of the server board/chassis, a list of accessories or other components you may need, troubleshooting information, and instructions on how to add and replace components on the Intel® Server Chassis H2000 family products. For the latest revision of this manual, go to http://www.intel.com/p/en_US/support.

Table 1. Intel® Server Chassis H2000 family product list

Product Code	Description
Intel® Server System H2312xxJR	Supports 4 node trays with 12 x 3.5" hard drive bay, 2 x 1200W CRPS
Intel® Server System H2216xxJR	Supports 4 node trays with 16 x 2.5" hard drive bay, 2 x 1200W CRPS
Intel® Server System H2312xxKR	Supports 4 node trays with 12 x 3.5" hard drive bay, 2 x 1600W CRPS
Intel® Server System H2216xxKR	Supports 4 node trays with 16 x 2.5" hard drive bay, 2 x 1600W CRPS

Manual Organization

Chapter 1 provides a brief overview of the Intel® Server Chassis H2000 family. In this chapter, you will find a list of the server system features, and figures of the system and components to help you identify your system components and their locations.

Chapter 2 provides instructions on adding and replacing components. Use this chapter for step-by-step instructions and diagrams for installing or replacing components such as the fan, power supply, and front panel board, among other components.

At the back of this document, you will find appendices on safety, “Getting Help”, and warranty information.

Additional Information and Software

For additional information about this family of products or any of their supported accessories, refer to the following resources available at <http://www.intel.com/support>.

Table 2. Server Chassis References

For this information or software	Use this Document or Software
For in-depth technical information about this product.	<i>Intel® Server Chassis H2000 Family Technical Product Specification</i> See the section on the web page titled, “Architecture/Specifications”.
For installation of supported spares and accessories	<i>Intel® Server Chassis H2000, H2000WP, and H2000LP Family Quick Installation User’s Guide</i> See the section on the web page titled, “System Integration/User Guides/Compatibility”.
For a list of supported Intel® spares and accessories	<i>Spares and Configuration Guide</i> See the section on the web page titled, “Documents and Guides”.

Preface

For this information or software	Use this Document or Software
For server configuration guidance and compatibility	Intel® Server Configurator Tool To be provided later.
For system power budget guidance	Power Budget Analysis Tool To be provided later.
For software to manage your Intel® Server System.	Intel® Server Management Software See the section on the web page titled, “Software/Code”.
For system firmware updates and onboard device drivers	Intel® Deployment Assistant DVD Firmware and Drivers See the section on the web page titled, “Software/Code”.
Product Safety and Regulatory document	<i>Intel® Server Products - Product Safety and Regulatory Compliance Document</i> See the section on the web page titled, “Regulations/Certification/Compliance”.

Table of Contents

Safety Information	iii
Preface.....	v
1 Server System Features	1
Server System Feature Overview	1
Server Chassis Parts	2
Front Panel.....	4
Bezel 4	
Hot-Swap SAS/SATA Backplane.....	5
Dummy Tray Cover	7
2 Hardware Installations and Upgrades	8
Before You Begin	8
Tools and Supplies Needed	8
System Reference	8
Removing and Installing the Front Bezel.....	9
Removing the Front Bezel.....	9
Installing the Front Bezel.....	9
Removing and Installing the Chassis Top Cover.....	10
Removing the Chassis Top Cover	10
Installing the System Cover	10
Removing and Installing the Compute Node Tray	11
Installing the Node Tray.....	11
Removing the Node Tray	12
Removing and Installing the Redundant Power Supply Unit.....	13
Removing the Power Supply Unit.....	14
Installing the Power Supply Unit	14
Installing and Removing Hot-swap Hard Drive	14
Installing a Hard Disk Drive into 3.5" Hard Drive Carrier	15
Installing a Hard Disk Drive into 2.5" Hard Drive Carrier	15
Installing and Removing the 2.5" Backplane Board	16
Removing the 2.5" Backplane board.....	16
Installing the 2.5" Backplane Board	18
Installing and Removing the 3.5" Backplane Board	19
Removing the 3.5" Backplane board.....	19
Installing the Server Board.....	21
Installing and Removing the Power Distribution Board.....	22
Removing the PDB	22
Installing the PDB.....	24
Replacing the Front Control Panel board	25
Removing the Front Control Panel	25
Installing Front Control Panel Board.....	27
Rack Mounting the Chassis.....	29
Intel® AXCELVRAIL Rail Kit	29
Mounting the Chassis to Rack.....	30
Removing the Chassis from Rack	32

Appendix A: Technical Reference	34
Power Supply Input Voltages.....	34
Power Supply Output Voltages.....	34
System Environmental Specifications	34
Appendix B: Regulatory and Compliance Information	36
Appendix C: Getting Help.....	37
Warranty Information	37
Appendix D: Intel® Server Issue Report Form.....	38

List of Figures

Figure 1. Intel® Server Chassis H2000 Family (H2312xx as demonstrated)	1
Figure 2. Intel® Server Chassis H2000 Overview (H2312xx as Demonstrated).....	2
Figure 3. Front View of Intel® Server Chassis H2312xx with 12x3.5" HDD bays	3
Figure 4. Front View of Intel® Server Chassis H2216xx with 16x2.5" HDD bays	3
Figure 5. Rear View of Intel® Server Chassis H2000 with Power Supply Unit	3
Figure 6. HDD Array Scheme on Intel® Server Chassis H2312xx.....	3
Figure 7. HDD array scheme on Intel® Server Chassis H2216xx	4
Figure 8. Front Panel Options.....	4
Figure 9. Front view of System Bezel.....	4
Figure 10. 12 x 3.5-inch Hard Drive Backplane Components (Front View)	5
Figure 11. 12 x 3.5-inch Hard Drive Backplane Components (Rear View).....	6
Figure 12. 16 x 2.5-inch Hard Drive Backplane Components (Front View)	6
Figure 13. 16 x 2.5-inch Hard Drive Backplane Components (Rear View).....	7
Figure 14. Dummy Tray Cover	7
Figure 15. Removing the Front Bezel	9
Figure 16. Installing the Front Bezel	9
Figure 17. Removing the System Top Cover	10
Figure 18. Installing the System Cover	11
Figure 19. Removing Dummy Tray Cover	11
Figure 20. Installing the Node Tray	12
Figure 21. Pulling out the Node Tray.....	13
Figure 22. Restore the Dummy Tray Cover	13
Figure 23. Removing the PSU.....	14
Figure 24. Installing the PSU.....	14
Figure 25. Installing Hard Disk Drive – installing 3.5" HDD to carrier	15
Figure 26. Installing Hard Disk Drive – Inserting 3.5" HDD assembly	15
Figure 27. Installing Hard Disk Drive – Installing 2.5" HDD to carrier	16
Figure 28. Installing Hard Disk Drive – Inserting 2.5" HDD assembly.....	16
Figure 29. Removing power cable protective cover	17
Figure 30. Removing the 2.5" backplane board	17
Figure 31. Align the backplane to the clamps on the chassis base	18
Figure 32. Installing the 2.5" backplane board	18
Figure 33. Installing power cable protective cover	19
Figure 34. Removing power cable protective cover	20
Figure 35. Removing the 2.5" backplane board	20
Figure 36. Align the backplane to the clamps on the chassis base	21
Figure 37. Installing the 2.5" backplane board	21
Figure 38. Installing power cable protective cover	22
Figure 39. Removing the upper PDB	23
Figure 40. Removing the lower PDB.....	23
Figure 41. Installing the lower PDB.....	24
Figure 42. Installing the upper PDB	25
Figure 43. Removing FP Assembly from Rack Handle	26
Figure 44. Disconnecting Control Panel Cable.....	26
Figure 45. Removing Control Panel Board	27
Figure 46. Installing Control Panel Board	28
Figure 47. Connecting Cable to Front Panel Board	28

List of Figures

Figure 48. Installing Control Panel Assembly to Rack Handle	29
Figure 49. Installing Inner Member of Rail Kit	30
Figure 50. Removing Inner Member from Slides	30
Figure 51. Installing Slides to Rack	31
Figure 52. Installing Inner Member to Chassis	31
Figure 53. Installing the Chassis to Rack	32
Figure 54. Extending Slides before Chassis Removal	32
Figure 55. Removing the Chassis from Rack	33

List of Tables

Table 1. Intel® Server Chassis H2000 family product list	v
Table 2. Server Chassis References	v
Table 3. Intel® Server Chassis H2000 Feature Summary	1
Table 4. CRPS Input Voltage	34
Table 5. CRPS Output Voltage.....	34
Table 6. System Environmental Limits Summary.....	34

1 Server System Features

This chapter briefly describes the main features of the Intel® Server Chassis H2000 family. This includes illustrations of the products, a list of the server system features, and diagrams showing the location of important components and connections on the server systems.

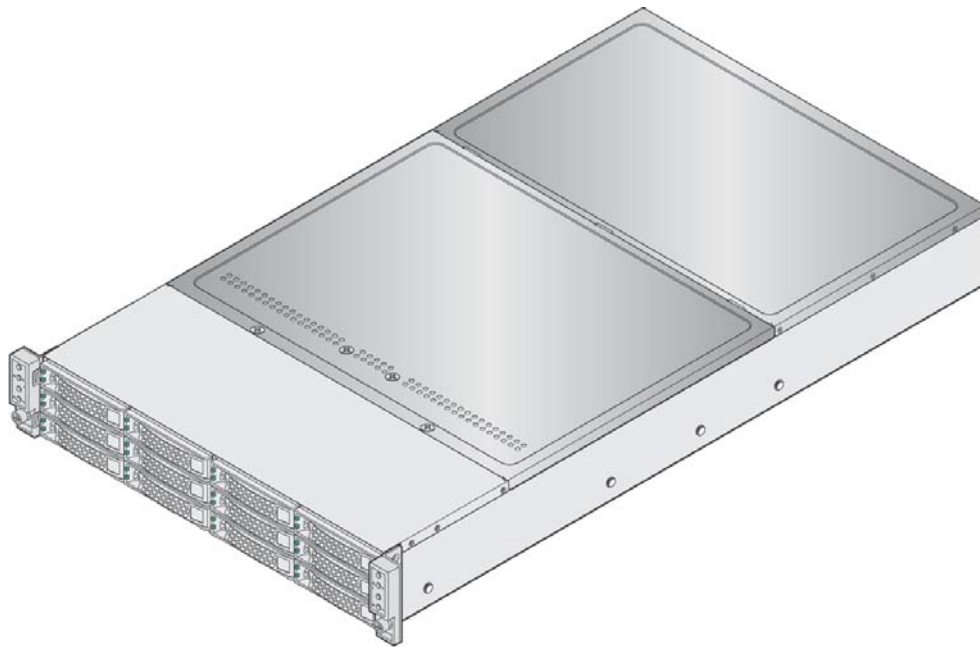

AF004655

Figure 1. Intel® Server Chassis H2000 Family (H2312xx as demonstrated)

Server System Feature Overview

Table 3 summarizes the features of the server systems.

Table 3. Intel® Server Chassis H2000 Feature Summary

Feature		Description
Dimensions	H2312JF	<ul style="list-style-type: none"> ▪ 3.46 inches (87.9 mm) high ▪ 17.24 inches (438.0 mm) wide ▪ 30.35 inches (771 mm) deep
	H2216JF	<ul style="list-style-type: none"> ▪ 3.46 inches (87.9 mm) high ▪ 17.24 inches (438.0 mm) wide ▪ 28.86 inches (733 mm) deep
Compute Node Support		<ul style="list-style-type: none"> ▪ Intel® Server Board S2600JF based Compute Node ▪ Intel® Server Board S2600WP based Compute Node ▪ Intel® Server Board S2400LP based Compute Node
System Fans		<ul style="list-style-type: none"> ▪ One internal power supply fan for each installed power supply unit.
Power Supply Options		<ul style="list-style-type: none"> ▪ 1200w AC Common Redundant Power Supply (CRPS), 80 plus Platinum with PFC, supporting

Server System Features

Feature	Description
	CRPS configuration. Chassis SKU: H2312xxJR, H2216xxJR . <ul style="list-style-type: none">▪ 1600w AC Common Redundant Power Supply (CRPS), 80 plus Platinum with PFC, supporting CRPS configuration. Chassis SKU: H2312xxKR, H2216xxKR.
Storage Bay Options	<ul style="list-style-type: none">▪ 12x 3.5-inch SATA/SAS HDD bays (SKU: H2312xx).▪ 16x 2.5-inch SATA/SAS HDD bays (SKU: H2216xx).
Available Rack Mount Kit Options	<ul style="list-style-type: none">▪ Basic slide rail kit, bundled with system package.

Server Chassis Parts

This section helps you identify the components of your server system. If you are near the system, you can also use the Quick Reference Label provided on the inside of the chassis cover to assist in identifying components.

The H2000 family is supporting 4 compute nodes in the chassis. The whole system view is as below (with top cover removed).

A	Front Control Panel
B	HDD bays
C	Upper and Lower Power Distribution Boards
D	Common Redundant Power Supply
E	Hot Swap Back Plane

Figure 2. Intel® Server Chassis H2000 Overview (H2312xx as Demonstrated)

There are two configurations of hard disk drives for H2000JF family.

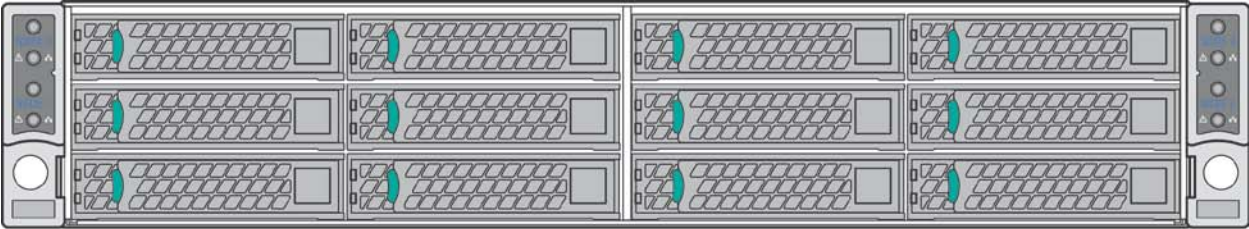

AF004635

Figure 3. Front View of Intel® Server Chassis H2312xx with 12x3.5" HDD bays

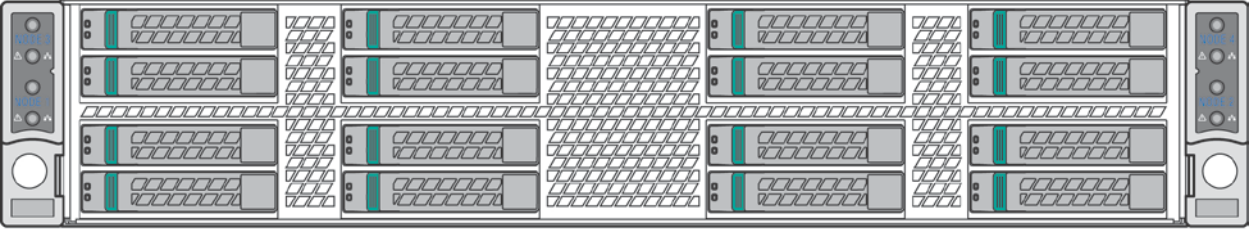

AF004637

Figure 4. Front View of Intel® Server Chassis H2216xx with 16x2.5" HDD bays

The Compute Node in the chassis has dedicated numbering by position.

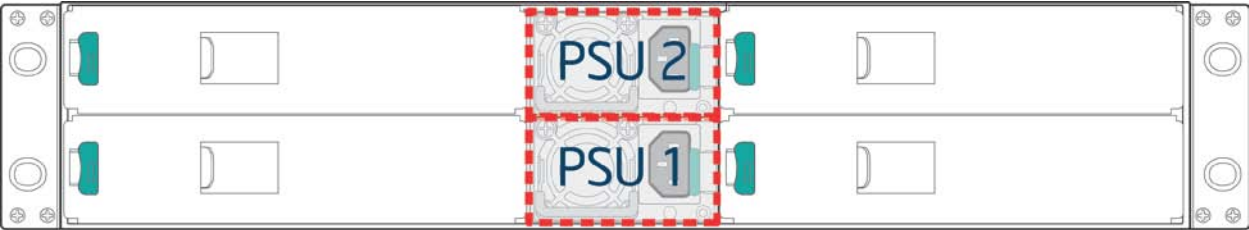

AF005313

Figure 5. Rear View of Intel® Server Chassis H2000 with Power Supply Unit

Each Compute Node has dedicated Hard Disk Drive array based on backplane controller design. Below are schemes for HDD array in correspondent to Compute Node.

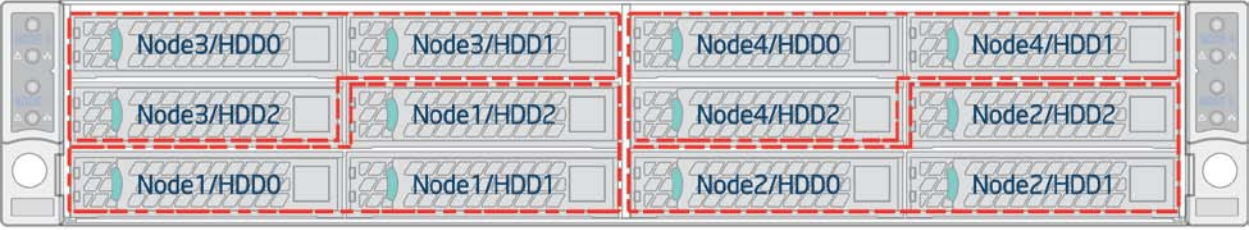

AF004511

Figure 6. HDD Array Scheme on Intel® Server Chassis H2312xx

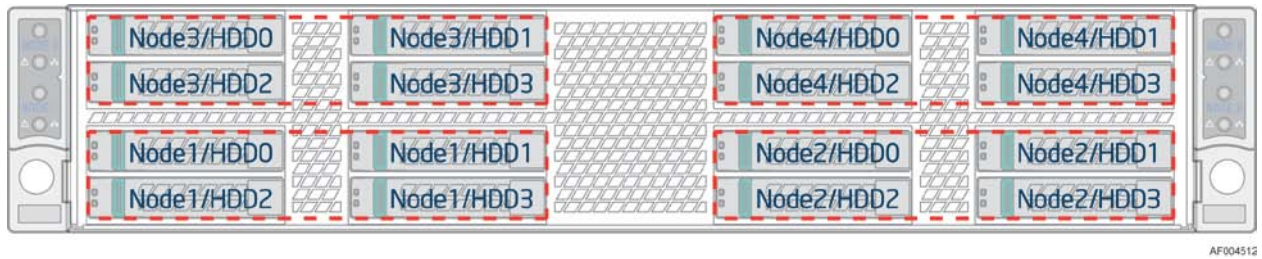
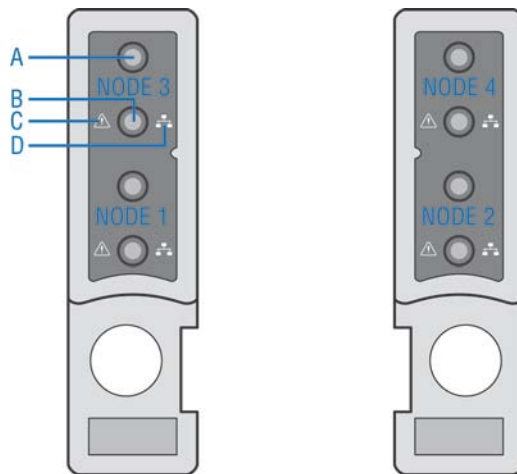

Figure 7. HDD array scheme on Intel® Server Chassis H2216xx

Front Panel

The system contains two sets of control panels on left and right rack handles. Each control panel contains two sets of control buttons and LEDs for each Compute Node. Following is the scheme of control panel.



A	System Power Button with LED
B	System ID LED Button
C	System Status LED
D	Network Link/Activity LED

Figure 8. Front Panel Options

Bezel

The front bezel is available as optional accessory for the server system:

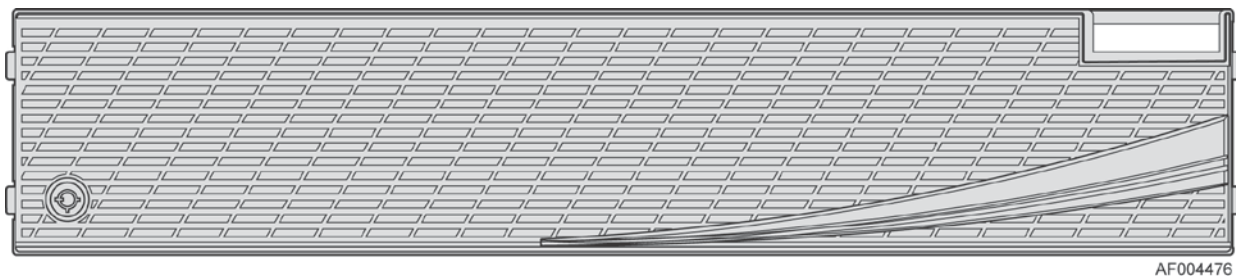

Figure 9. Front view of System Bezel

Hot-Swap SAS/SATA Backplane

The Hot-Swap SAS/SATA backplane serves as an interface between the motherboard and the system drives. The following diagrams show the location for each connector found on the backplane.

12 x 3.5-inch Hard Drive Backplane

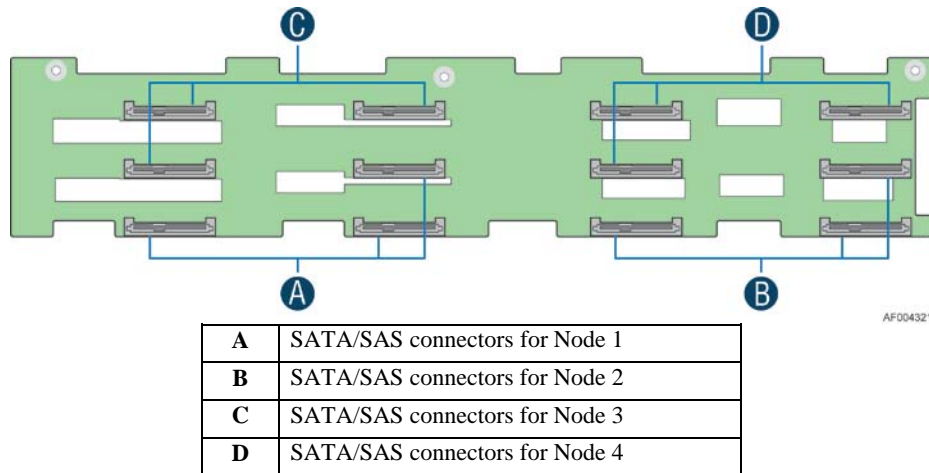
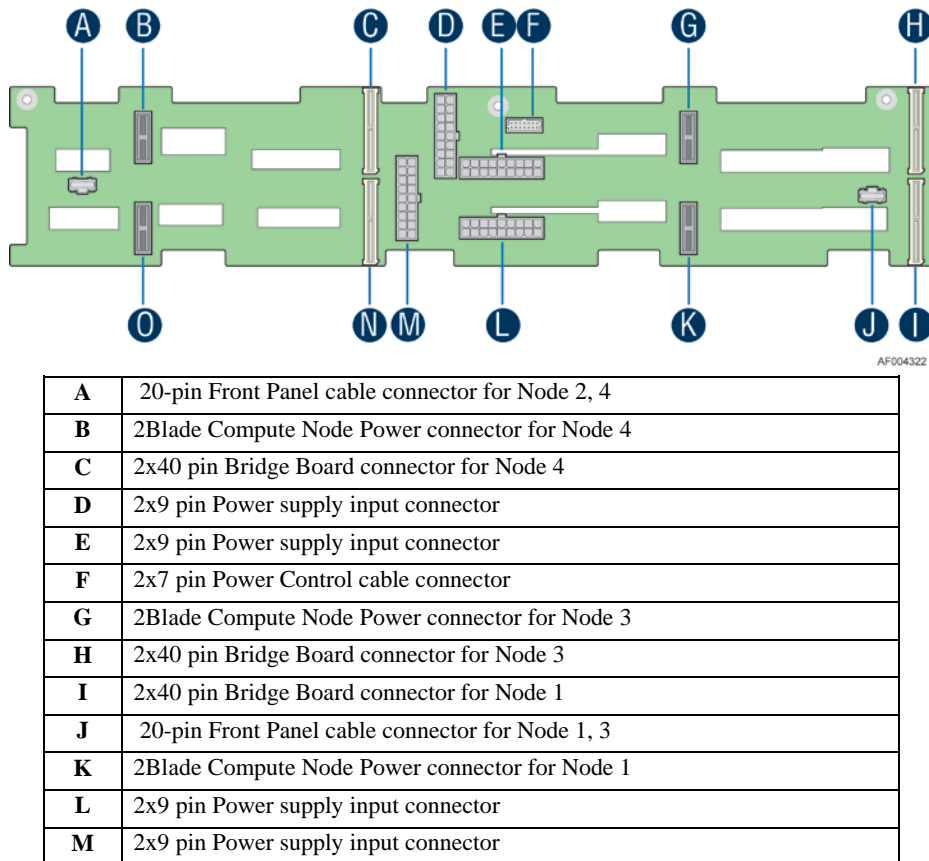

Figure 10. 12 x 3.5-inch Hard Drive Backplane Components (Front View)



N	2x40 pin Bridge Board connector for Node 2
O	2Blade Compute Node Power connector for Node 2

Figure 11. 12 x 3.5-inch Hard Drive Backplane Components (Rear View)

16 x 2.5-inch Hard Drive Backplane

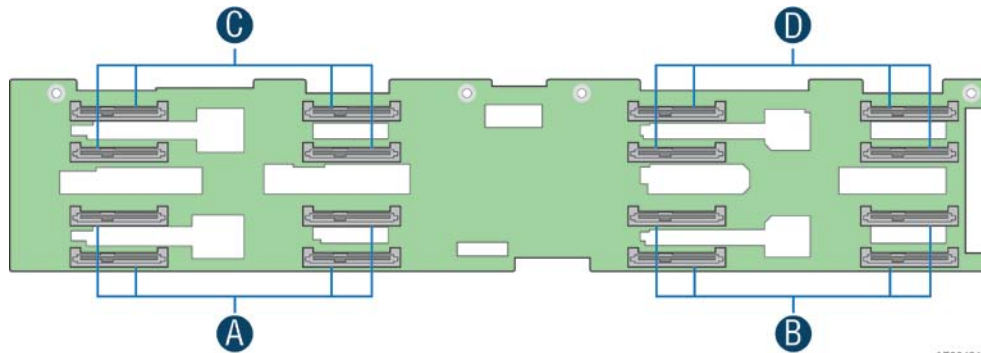

A	SATA/SAS connectors for Node 1
B	SATA/SAS connectors for Node 2
C	SATA/SAS connectors for Node 3
D	SATA/SAS connectors for Node 4

AF004314

Figure 12. 16 x 2.5-inch Hard Drive Backplane Components (Front View)

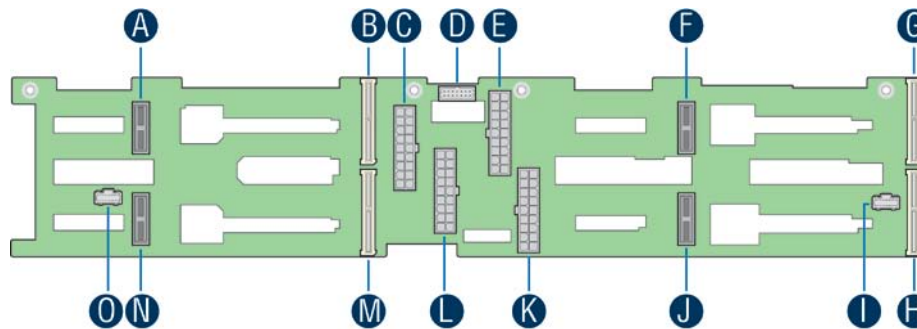

A	2Blade Compute Node Power connector for Node 4
B	2x40 pin Bridge Board connector for Node 4
C	2x9 pin Power supply input connector
D	2x7 pin Power Control cable connector
E	2x9 pin Power supply input connector
F	2Blade Compute Node Power connector for Node 3
G	2x40 pin Bridge Board connector for Node 3
H	2x40 pin Bridge Board connector for Node 1
I	20-pin Front Panel cable connector for Node 1, 3
J	2Blade Compute Node Power connector for Node 1
K	2x9 pin Power supply input connector
L	2x9 pin Power supply input connector
M	2x40 pin Bridge Board connector for Node 2

AF004315

N	2Blade Compute Node Power connector for Node 2
O	20-pin Front Panel cable connector for Node 2, 4

Figure 13. 16 x 2.5-inch Hard Drive Backplane Components (Rear View)

Dummy Tray Cover

The Dummy tray cover is shipped together with chassis. It must be removed before installing computing node tray, or it must be restored if the compute node tray is empty.

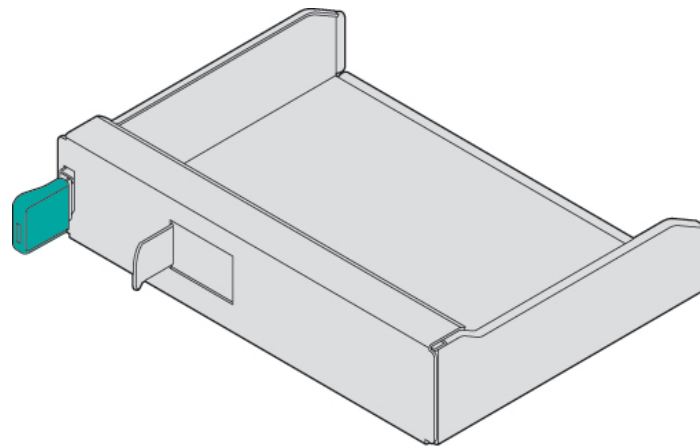

AF005216

Figure 14. Dummy Tray Cover

2 Hardware Installations and Upgrades

Before You Begin

Before working with your server product, pay close attention to the Safety Information at the beginning of this manual.

Note: Whenever you service the system, you must first power down the server and unplug all peripheral devices and the AC power cord.

Tools and Supplies Needed

- Phillips* (cross head) screwdriver (#1 bit and #2 bit)
- Needle nosed pliers
- Anti-static wrist strap and conductive foam pad (recommended)

System Reference

All references to left, right, front, top, and bottom assume the reader is facing the front of the chassis as it would be positioned for normal operation.

Note: The Intel® Server Chassis H2000 is shown for illustration purpose. Server components with the product family are identical.

Removing and Installing the Front Bezel

Removing the Front Bezel

If your system includes a front bezel, follow these steps to remove the front bezel:

1. Unlock the bezel if it is locked.
2. Remove the left end of front bezel from rack handle (see letter **A**).
3. Rotate the front bezel anticlockwise to release the latches on the right end from the rack handle (see letter **B**).

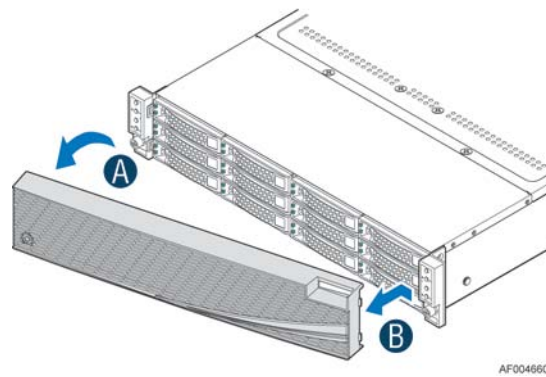

Figure 15. Removing the Front Bezel

Installing the Front Bezel

Note: Before installing the bezel, you must install the rack handles.

1. Lock the right end of the front bezel to the rack handle (see letter **A**).
2. Rotate the front bezel clockwise till the left end clicks into place (see letter **B**).
3. Lock the bezel if needed.

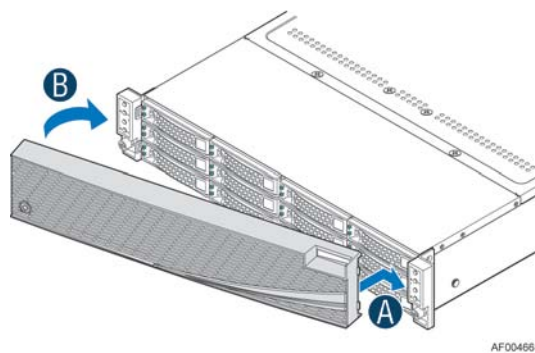

Figure 16. Installing the Front Bezel

Removing and Installing the Chassis Top Cover

Removing the Chassis Top Cover

The server Chassis must be operated with the top cover in place to ensure proper cooling. You will need to remove the top cover to add or replace components (backplane, main power cables, power distribution board) inside of the chassis. Before removing the top cover, power down the server and unplug all peripheral devices and the power cable(s).

Note: A non-skid surface or a stop behind the server system may be needed to prevent the server system from sliding on your work surface.

1. Observe the safety and ESD precautions at the beginning of this book.
2. Turn off all peripheral devices connected to the server. Turn off the server.
3. Disconnect the power cord.
4. Remove the screws (see letter **A**).
5. Lift the top cover from front end to more than 45 degrees (see letter **B**).
6. Remove the top cover.

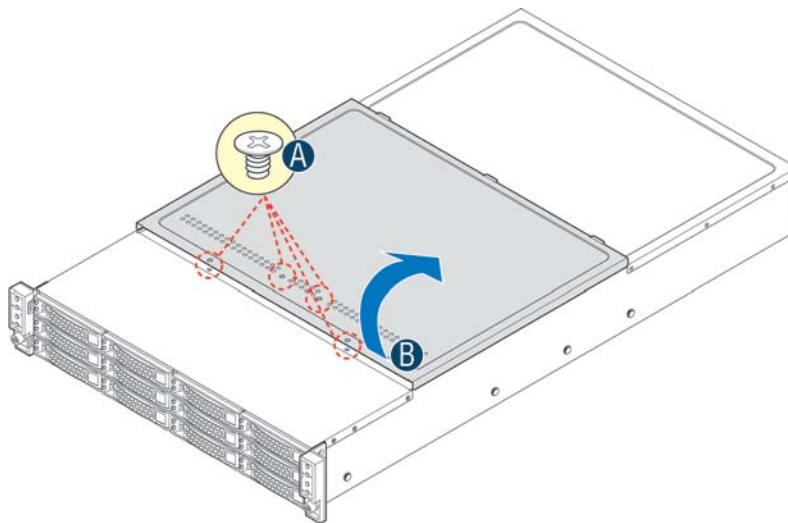

AF004902

Figure 17. Removing the System Top Cover

Installing the System Cover

1. Place system cover onto the chassis and slide forward to engage recessed edge at front of cover (see letter **A**).
2. Rotate the front end of top cover down to position and fix screws (see letter **B**).

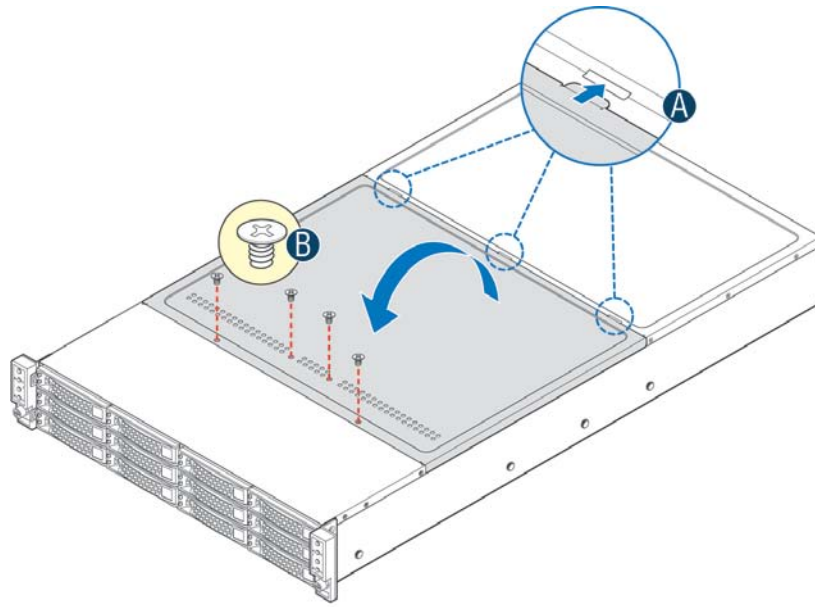

AF005080

Figure 18. Installing the System Cover

Removing and Installing the Compute Node Tray

Each Compute Node tray is identical in the chassis. They are designed for either “cold” or “hot” swappable. The Node Tray can only be plugged from rear chassis.

Installing the Node Tray

1. Remove the dummy tray cover.

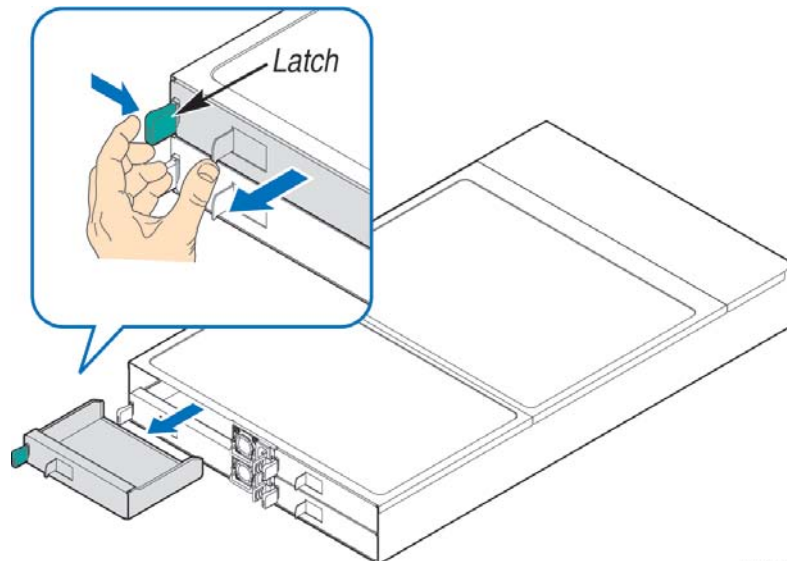

AF005217

Figure 19. Removing Dummy Tray Cover

2. Align and slide in the Node Tray to the chassis rail.
3. Push the Node Tray along the rail until the latch locks in position with a “tick”.

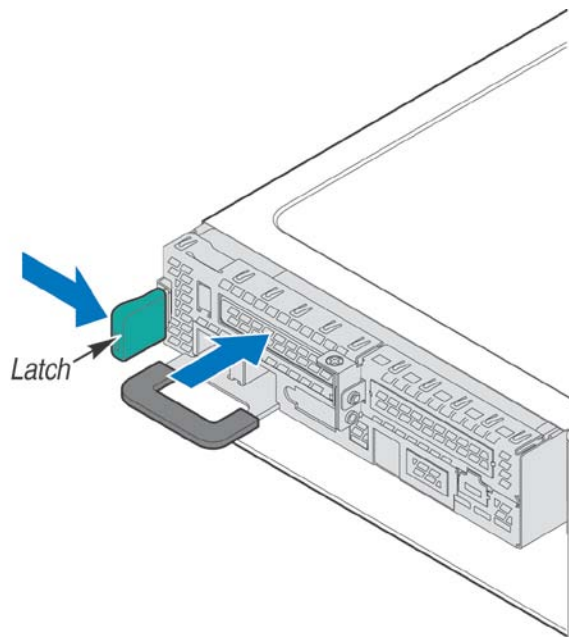

AF004246

Figure 20. Installing the Node Tray

Removing the Node Tray

1. Carefully push the latch in, on the left hand side of the Node Tray.
2. Pull the handle with the Node Tray while still pressing the latch.

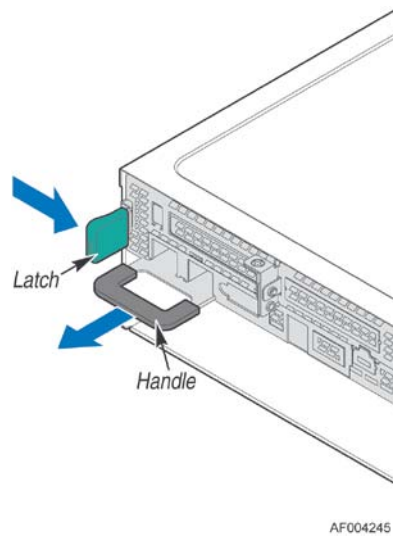

Figure 21. Pulling out the Node Tray

3. Restore the Dummy Tray Cover.

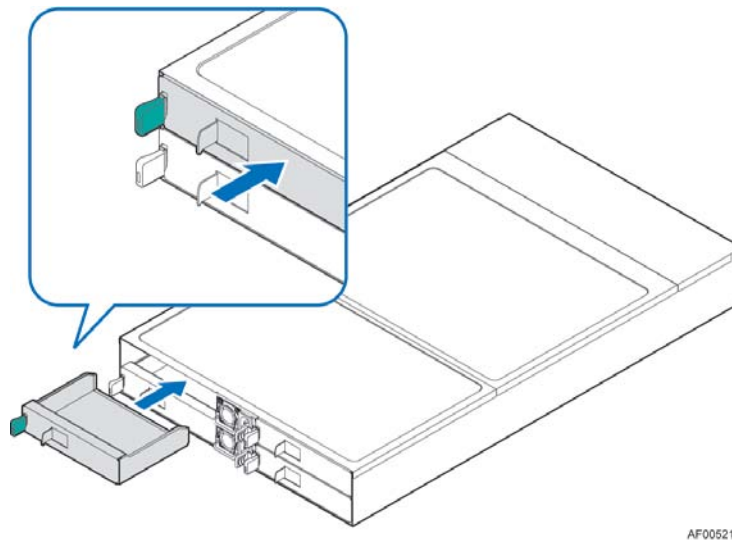

Figure 22. Restore the Dummy Tray Cover

Removing and Installing the Redundant Power Supply Unit

The system equipped with two CRPS for redundancy. Each of them can be hot swappable.

Caution: Installing two Power Supply Units with different wattage ratings in a system is not supported. Doing so will not provide Power Supply Redundancy and will result in multiple errors being logged by the system.

Removing the Power Supply Unit

1. Carefully push in the latch on the right hand of PSU.
2. Pull the handle with the PSU while still pressing the latch.

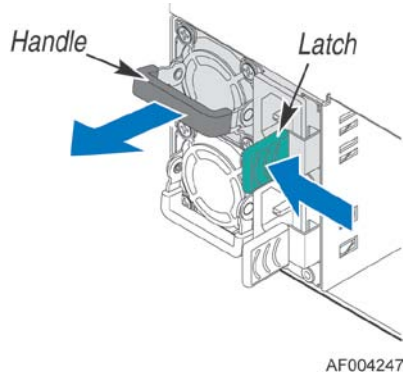

Figure 23. Removing the PSU

Installing the Power Supply Unit

1. Align and slide in the PSU to the power cage rail.
2. Push the PSU along the rail until the latch locks in position with a “tick”.

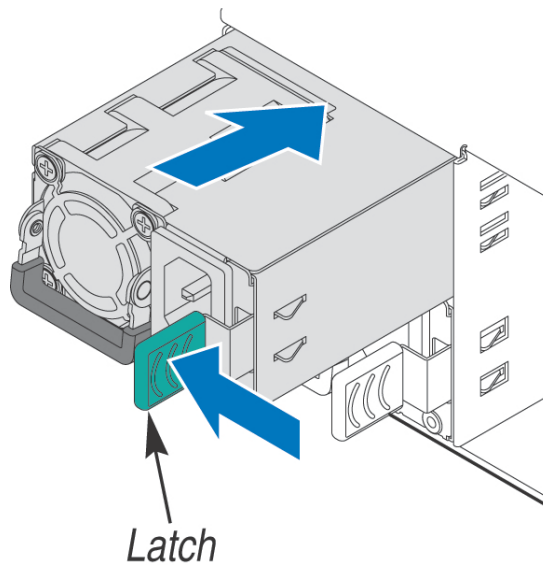

Figure 24. Installing the PSU

Installing and Removing Hot-swap Hard Drive

Caution: If you don't install all drives, empty drive bays must be occupied by carriers with plastic drive blank provided to maintain proper system cooling.

Installing a Hard Disk Drive into 3.5" Hard Drive Carrier

1. Remove the four screws securing the HDD interface bracket and install 3.5" HDD with screws shown in letter **A**.

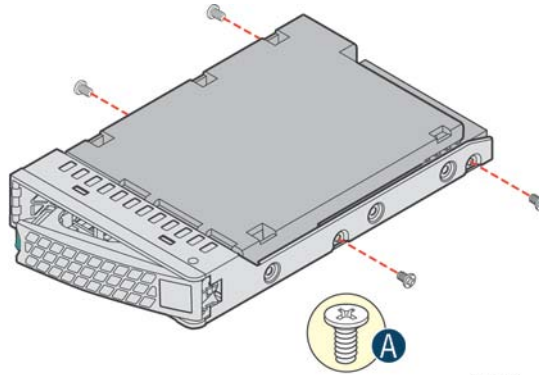

Figure 25. Installing Hard Disk Drive – installing 3.5" HDD to carrier

2. With the lever open, insert the hard disk drive assembly into the chassis (see letter **A**). Push in the lever to lock it into place (see letter **B**).

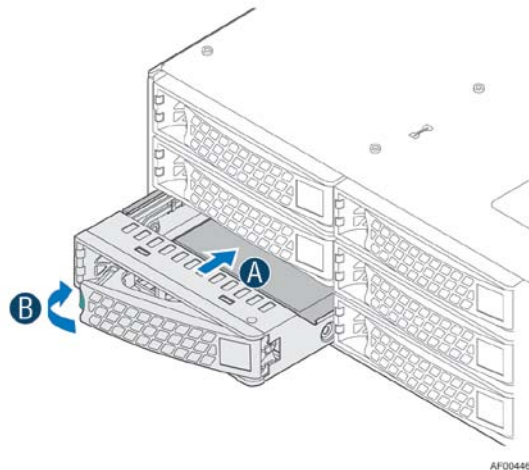
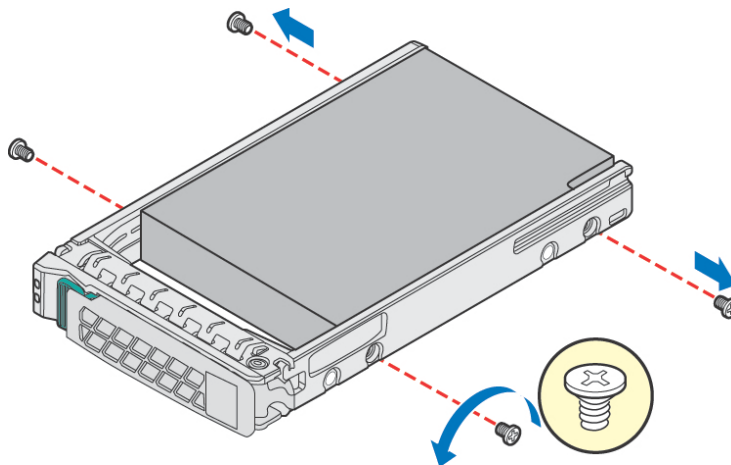

Figure 26. Installing Hard Disk Drive – Inserting 3.5" HDD assembly

Installing a Hard Disk Drive into 2.5" Hard Drive Carrier

1. Remove the four screws securing the plastic drive blank from the 2.5" HDD carrier and install the 2.5" HDD with screws shown in below drawing.



AF004451

Figure 27. Installing Hard Disk Drive – Installing 2.5" HDD to carrier

2. With the lever open, insert the hard disk drive assembly into the chassis, then push in the lever to lock it into place (see letter **F**).

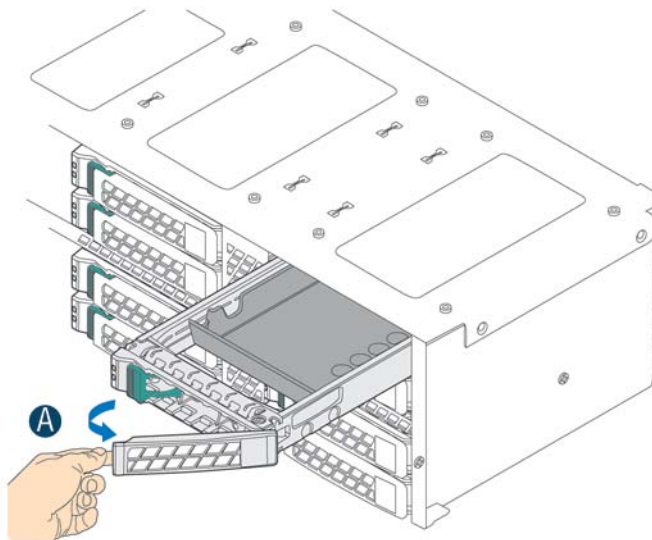

AF004452

Figure 28. Installing Hard Disk Drive – Inserting 2.5" HDD assembly

Installing and Removing the 2.5" Backplane Board

Removing the 2.5" Backplane board

1. Disconnect all cables from the backplane board.
2. Remove power cable protective cover.

Figure 29. Removing power cable protective cover

3. Remove the four screws to release the backplane board from chassis.
4. Straightly lift up the backplane board to remove from the chassis holder.

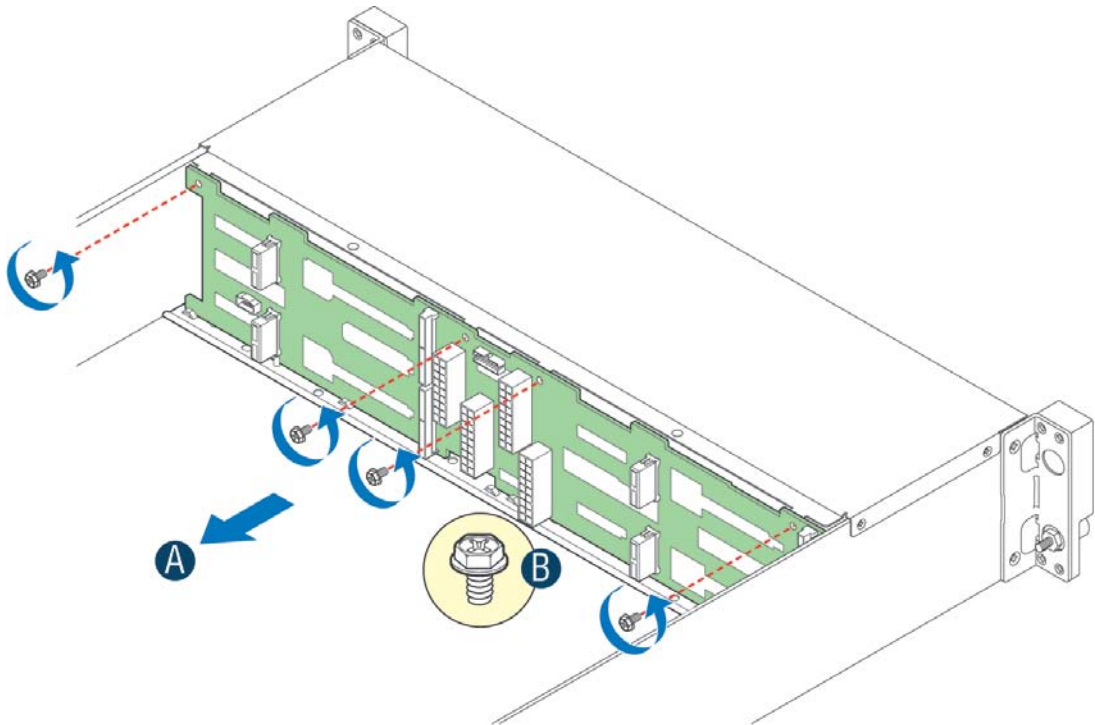

AF004691

Figure 30. Removing the 2.5" backplane board

Installing the 2.5" Backplane Board

1. Place the backplane board into the clamps on chassis base.

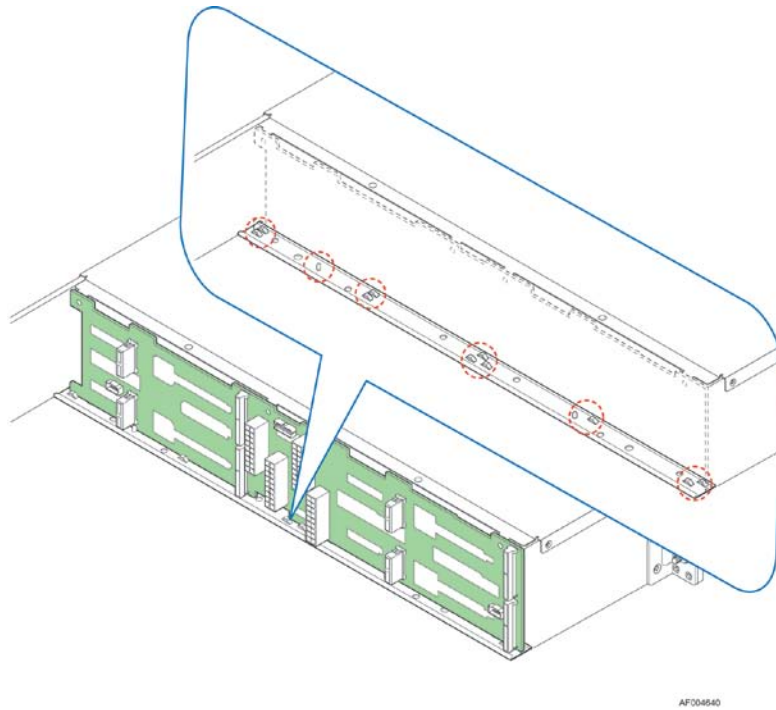

Figure 31. Align the backplane to the clamps on the chassis base

2. Secure the backplane board with four screws (see letter **B**).

Figure 32. Installing the 2.5" backplane board

3. Reconnect all cables to the backplane.
4. Install power cable protective cover.

Figure 33. Installing power cable protective cover

Installing and Removing the 3.5" Backplane Board

Removing the 3.5" Backplane board

1. Disconnect all cables from the backplane board.
2. Remove power cable protective cover.

Figure 34. Removing power cable protective cover

3. Remove the three screws to release the backplane board from chassis.
4. Straightly lift up the backplane board to remove from the chassis holder.

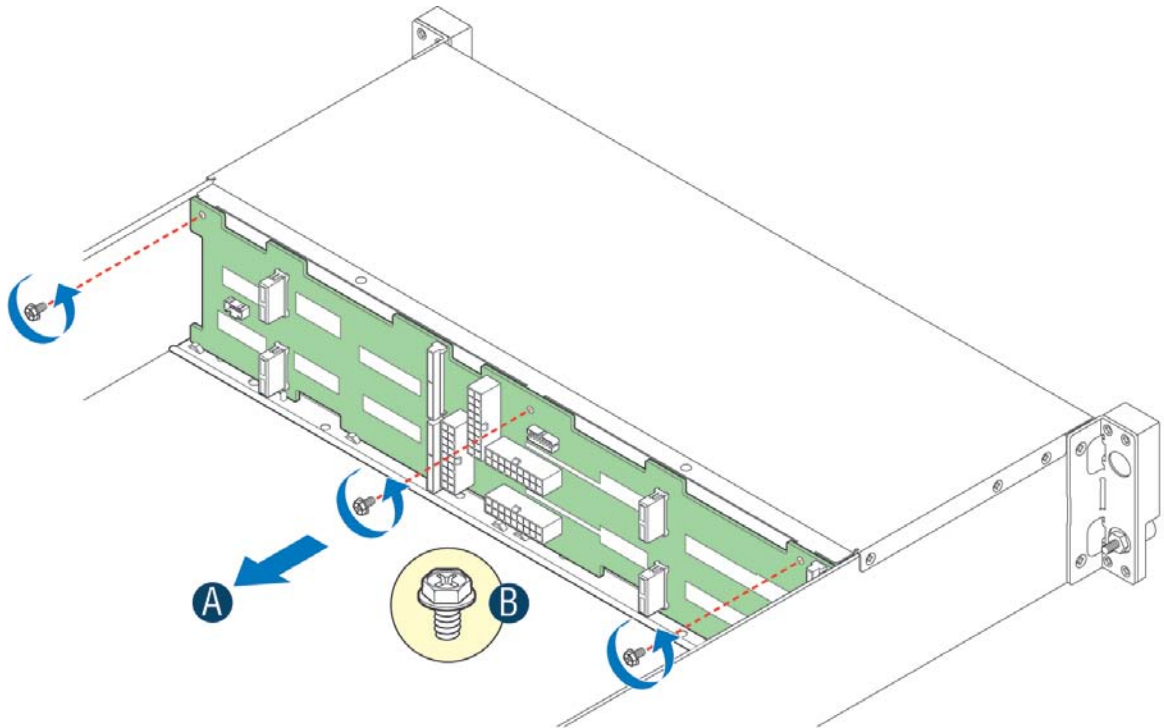
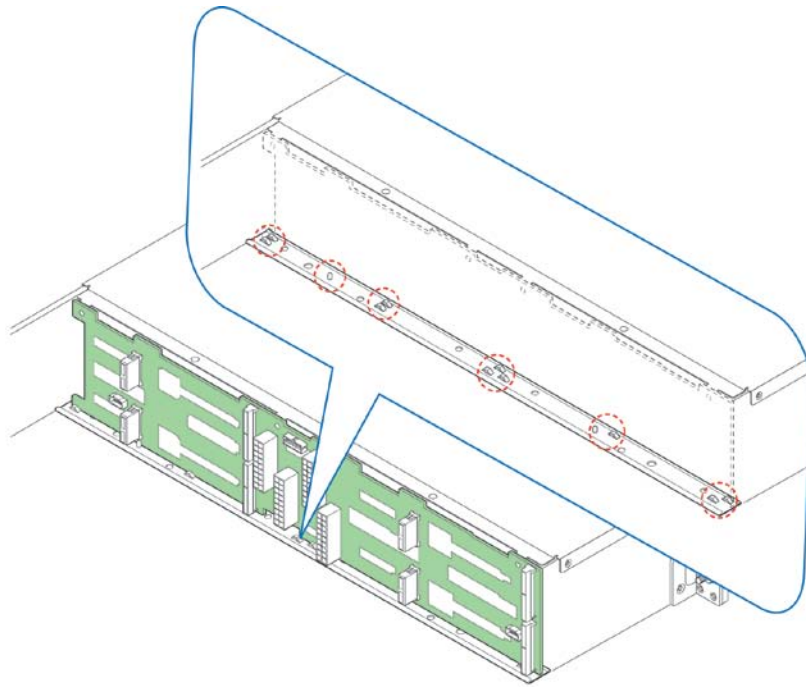

Figure 35. Removing the 2.5" backplane board

Installing the Server Board

1. Place the backplane board into the clamps on chassis base.



AF004560

Figure 36. Align the backplane to the clamps on the chassis base

2. Secure the backplane board with three screws (see letter **B**).

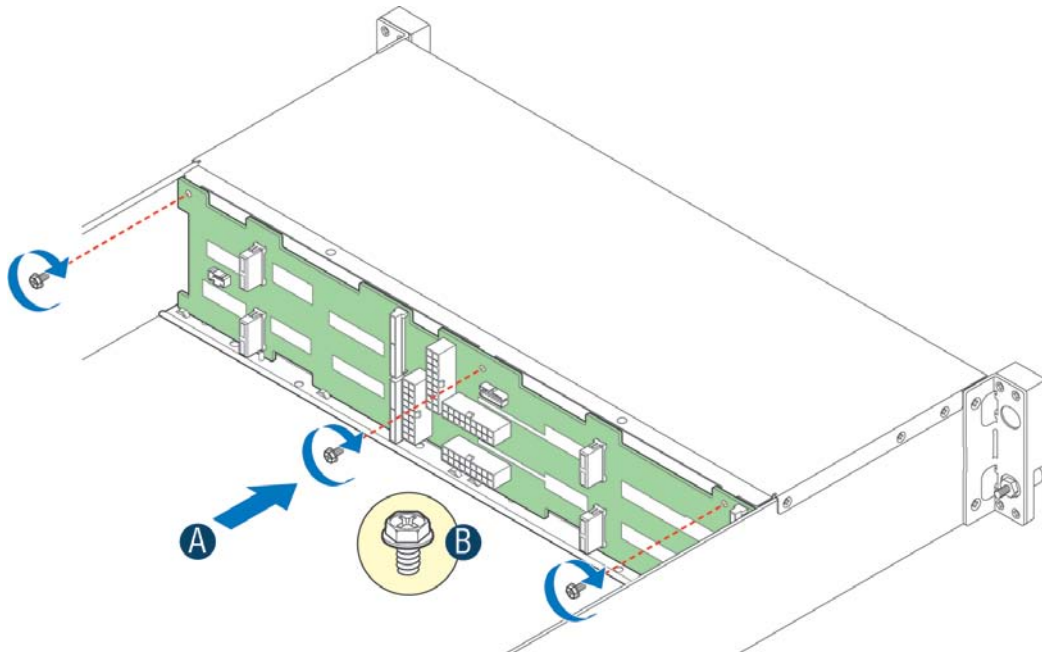

AF004643

Figure 37. Installing the 2.5" backplane board

3. Reconnect all cables to the backplane.
4. Install power cable protective cover.

Figure 38. Installing power cable protective cover

Installing and Removing the Power Distribution Board

Removing the PDB

1. Remove top cover and power supply units from chassis.
2. Remove power cables and PMBus* cable between PDB and backplane.
3. Release the four screws of upper PDB board and remove it.

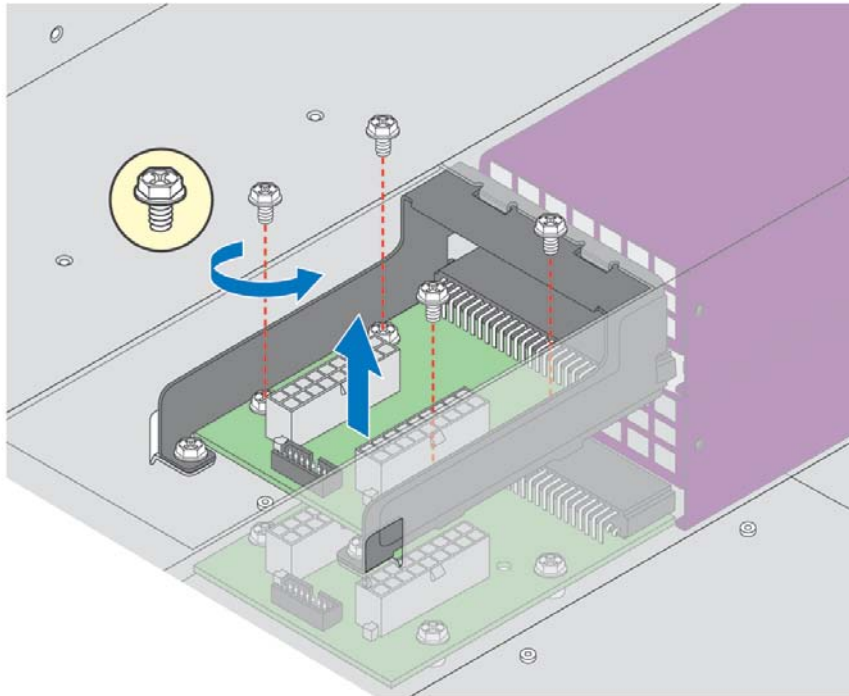

AF004696

Figure 39. Removing the upper PDB

4. Release the four screws of lower PDB board and remove it.

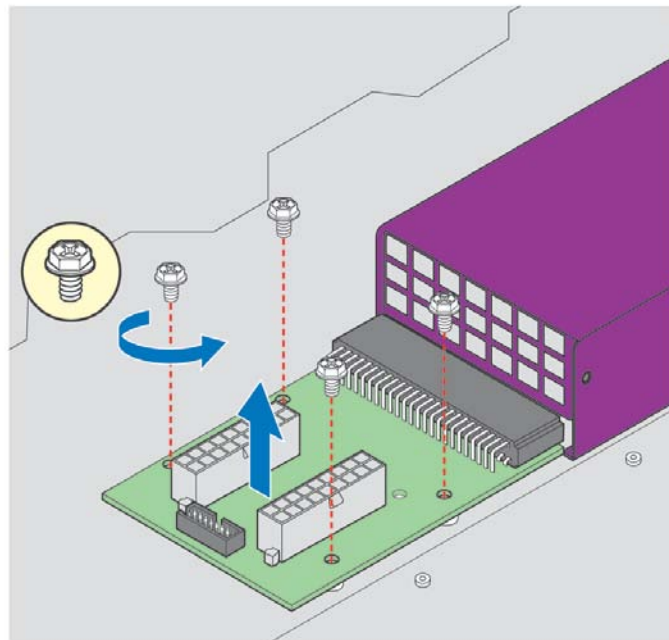

AF004697

Figure 40. Removing the lower PDB

Installing the PDB

1. Remove top cover and power supply units from chassis.
2. Install the lower PDB first and secure with four screws.

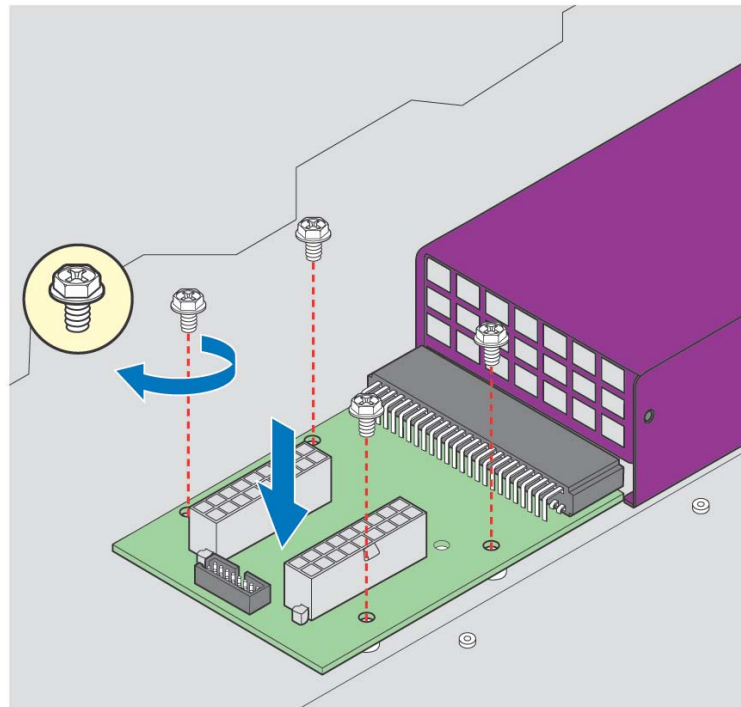

AF004694

Figure 41. Installing the lower PDB

3. Connect the power cables and PMBus* cable to lower PDB.
4. Install the upper PDB and secure with four screws.

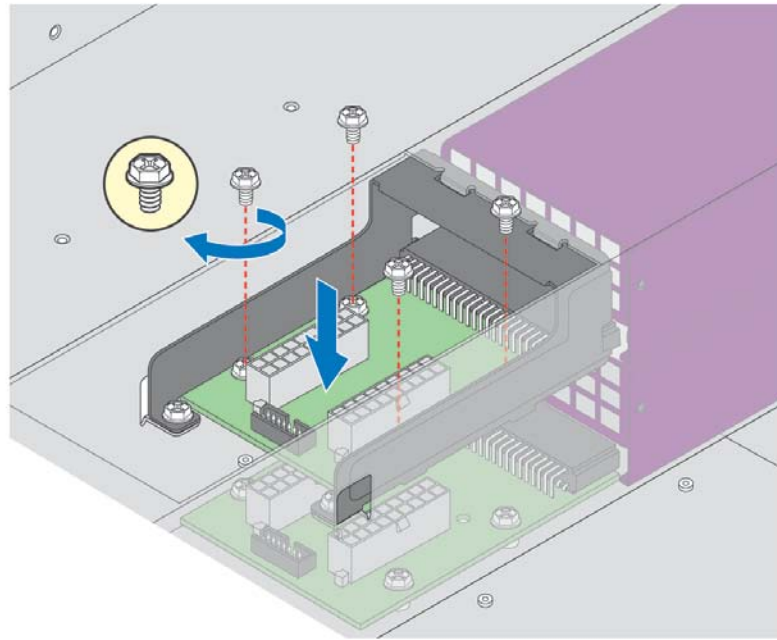

AF004695

Figure 42. Installing the upper PDB

5. Connect power cables and PMBus* cable to upper PDB.
6. Close top cover and install power supply units.

Replacing the Front Control Panel board

Removing the Front Control Panel

1. Loosen and remove four screws on the back of handle. Be careful of the control panel cable on the back.

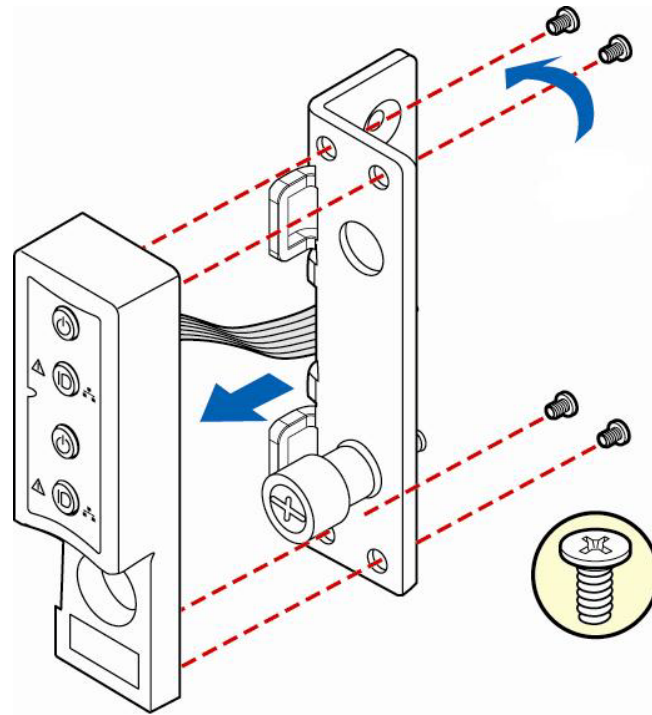

AF004709

Figure 43. Removing FP Assembly from Rack Handle

2. Disconnect the cable from the control panel board.

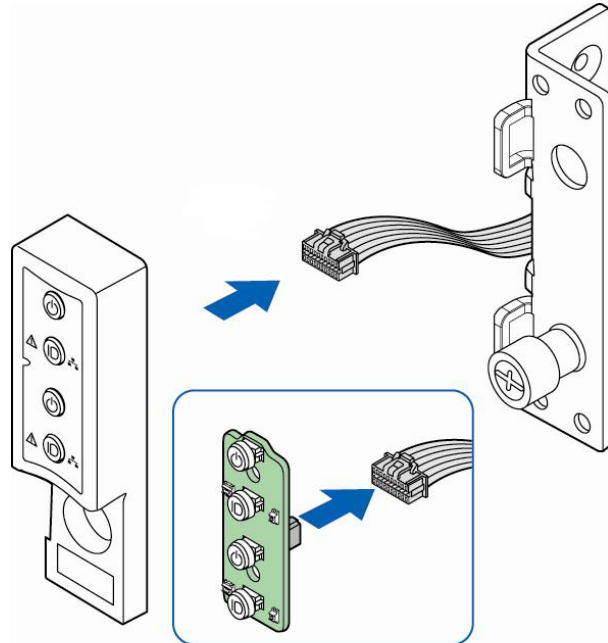

AF004711

Figure 44. Disconnecting Control Panel Cable

3. Loosen and remove two screws from back of control panel board, so the board can be removed out.

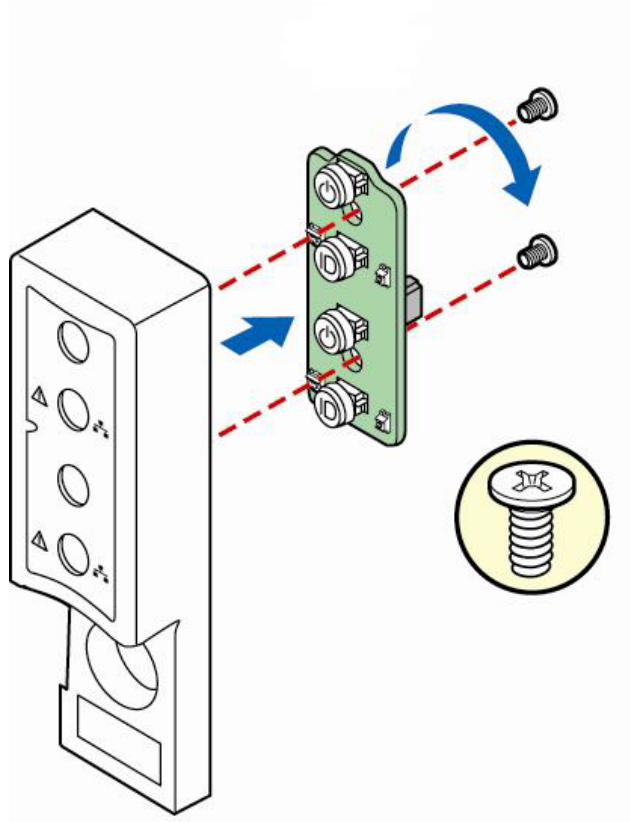

AF004712

Figure 45. Removing Control Panel Board

Installing Front Control Panel Board

1. Install front control panel board to panel shell.

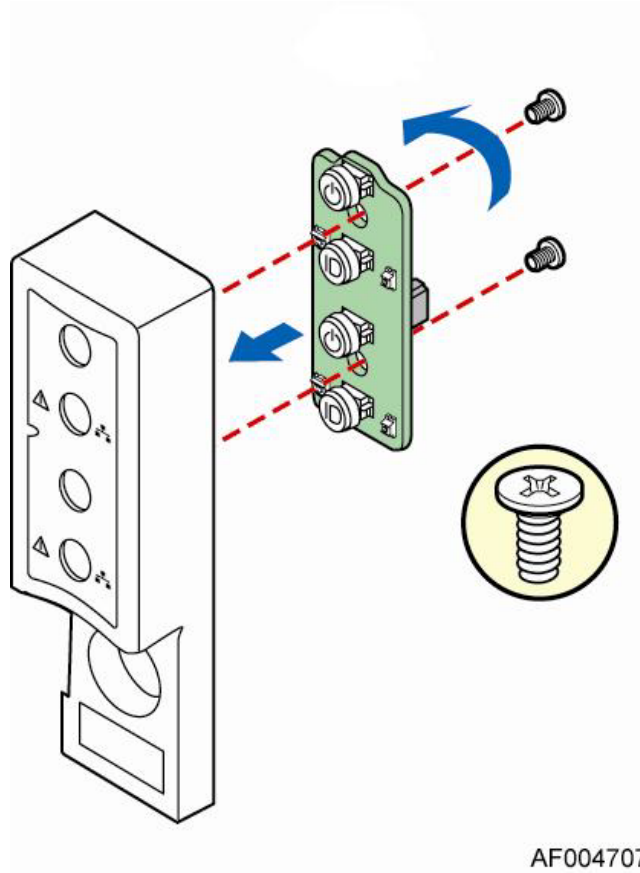

Figure 46. Installing Control Panel Board

2. Connect cable to front panel board.

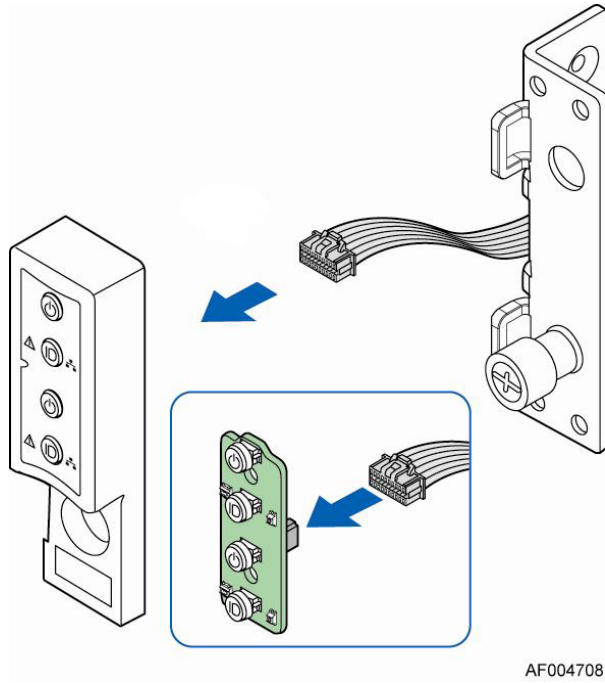

Figure 47. Connecting Cable to Front Panel Board

3. Install front control panel assembly to chassis handle.

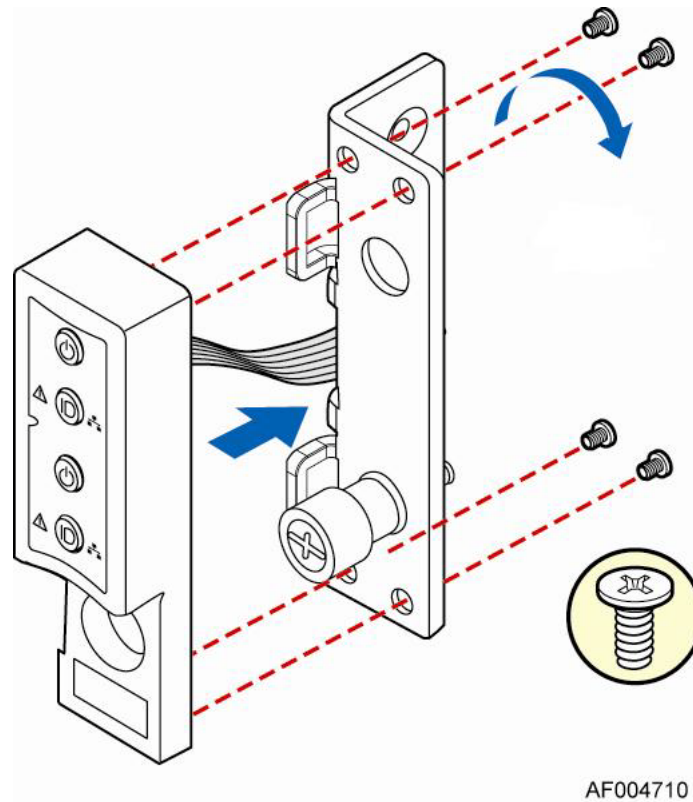

Figure 48. Installing Control Panel Assembly to Rack Handle

Rack Mounting the Chassis

Intel® AXVELVRAIL Rail Kit

Intel® AXVELVRAIL is a half extension value rail kit, which is bundled with H2000JF chassis. The rail kit can hold a chassis of maximum 130lb/59kg.

This rail kit can also be ordered as a separate spare. (Order number: **920970**)

Advisory Note: The AXVELVRAIL value rack mount rail kit is not designed to support shipment of the server system while installed in a rack.

Warning: To prevent injury, before installing the server, make sure you check the weight of the server to ensure it does not exceed the specified maximum weight of the rack rails. In addition, use a mechanical assist to install server and align the server into the rack rails correctly. If server is not aligned and engaged into the rack rails correctly, the server may fall off the rails causing injury.

Note: It will only support specific rack type with 3/8" square and 7.1mm round holes.

Mounting the Chassis to Rack

The slide rail kit, which is bundled with Intel® Server System H2000JF family is packed in the same shipping box together with the chassis.

Based on the chassis design, the inner member of the rail is actually at the down side of the chassis. See below for inner member installation position.

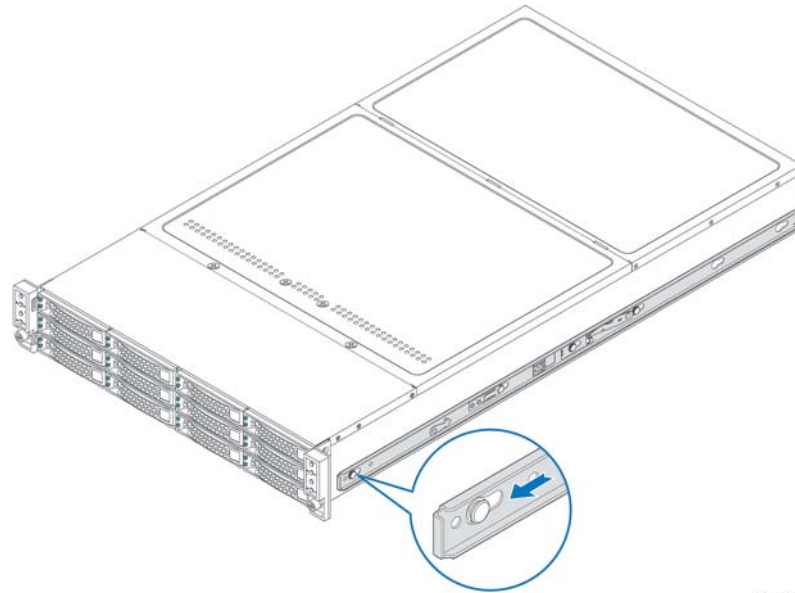

AF005871

Figure 49. Installing Inner Member of Rail Kit

Following are the steps to install chassis to rack:

1. Preparation before slide installation.

RACK INSTALLATION – REMOVE INNER MEMBER FROM SLIDES

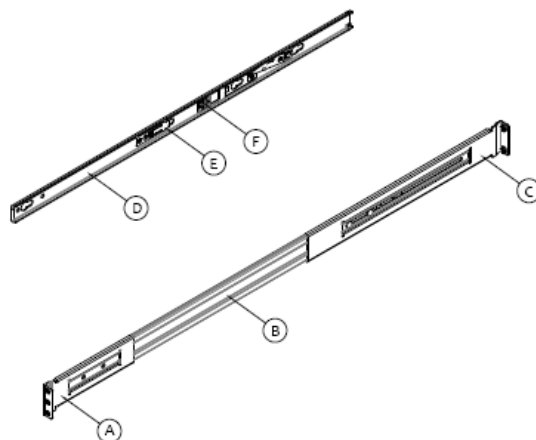

Slides components:
 A - front bracket; B - outer member;
 C - rear bracket; D - inner member;
 E - safety locking pin; F - release button.

Pull release button to remove inner member from slides.

Figure 50. Removing Inner Member from Slides

2. Install slides to rack.

RACK INSTALLATION – INSTALL SLIDES TO RACK

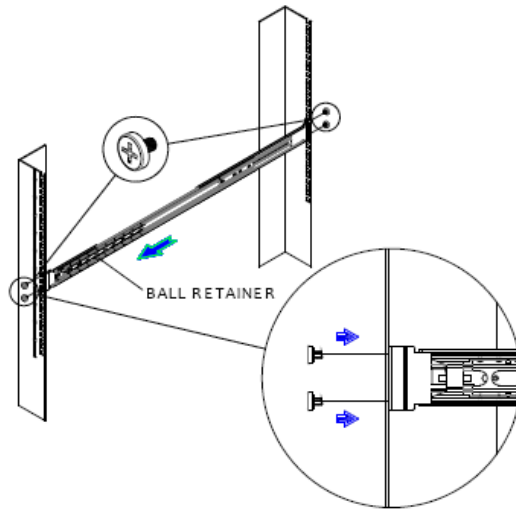

Align brackets to desired vertical position on rack and insert fasteners.
Move ball retainer to the front of slides.

Figure 51. Installing Slides to Rack

3. Install inner members to chassis.

CHASSIS INSTALLATION – INSTALL INNER MEMBER TO CHASSIS

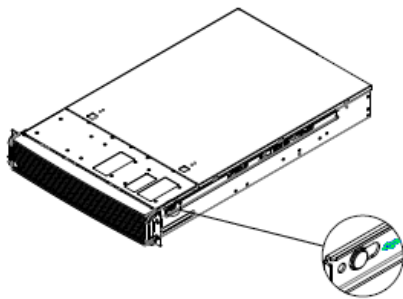

Align inner member key holes to standoffs on chassis, move inner member following the direction in left pictures.

Figure 52. Installing Inner Member to Chassis

4. Install chassis to fixed slides.

CHASSIS INSTALLATION – INSTALL CHASSIS TO FIXED SLIDES

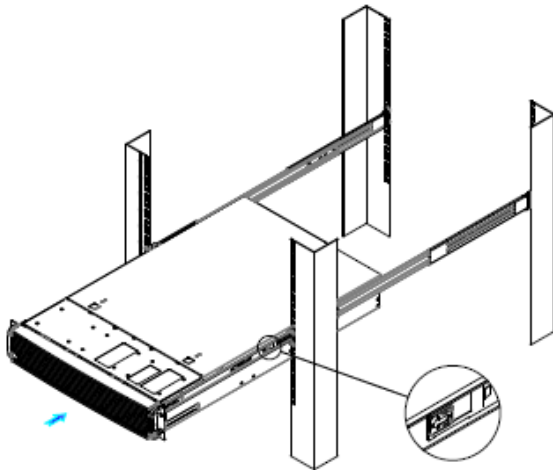

Pull the release button in the inner member to release the lock and allow the chassis to close.

Figure 53. Installing the Chassis to Rack

Removing the Chassis from Rack

Following the below steps to remove the chassis from Rack.

1. Extend slides.

CHASSIS REMOVAL – EXTEND SLIDES

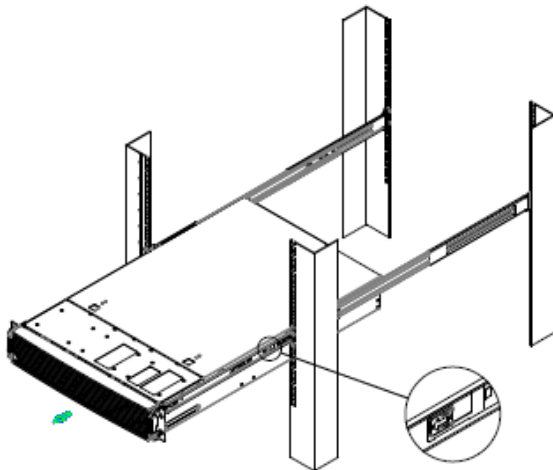

Fully extend the slides until it is in the locked position, pull the release button to release lock and disconnect inner member from slides.

Figure 54. Extending Slides before Chassis Removal

2. Remove Inner Member from Chassis.

CHASSIS REMOVAL – REMOVE INNER MEMBER FROM CHASSIS

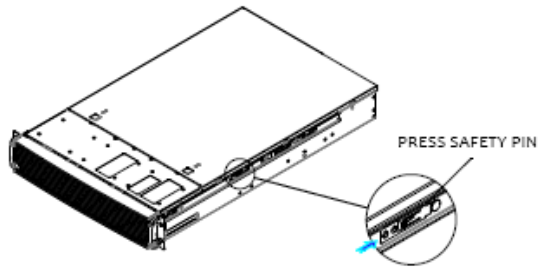

Press safety locking pin to release inner member from chassis.

Figure 55. Removing the Chassis from Rack

Appendix A: Technical Reference

Power Supply Input Voltages

Table 4. CRPS Input Voltage

Parameter	Min	Rated	Max	Start up VAC	Power Off VAC
110V _{AC}	90 V _{rms}	100-127 V _{rms}	140 V _{rms}	85 V _{AC} ± 4V _{AC}	70V _{AC} ±5V _{AC}
220V _{AC}	180 V _{rms}	200-240 V _{rms}	264 V _{rms}		
Frequency	47 Hz	50/60 Hz	63 Hz		

Power Supply Output Voltages

Table 5. CRPS Output Voltage

Parameter	Min	Nom	Max	Unit	Tolerance
+12V _{STB}	+11.40V	+12.000V	+12.60V	V _{rms}	±5%
+12V	+11.40V	+12.000V	+12.60V	V _{rms}	±5%

System Environmental Specifications

The following table defines the system level operating and non-operating environmental limits.

Table 6. System Environmental Limits Summary

Parameter	Limits
Operating Temperature	+10°C to +35°C with the maximum rate of change not to exceed 10°C per hour.
Non-Operating Temperature	-40°C to +70°C
Non-Operating Humidity	90%, non-condensing at 35°C
Acoustic noise	Sound power: <ul style="list-style-type: none"> ▪ 3.5" HDD SKU: 6.9BA at idle and 7.4BA at active mode ▪ 2.5" HDD SKU: 6.5BA at idle and 7.07BA at active mode In typical office ambient temperature. (23 +/- 2 degrees C).
Shock, operating	Half sine, 2 g peak, 11 milliseconds
Shock, unpackaged	Trapezoidal, 25 g, velocity change 205 inches/second (80 lbs to < 100 lbs)

Appendix A: Technical Reference

Parameter	Limits
Shock, packaged	Non-palletized free fall in height 18 inches (80 lbs to < 100 lbs)
Vibration, unpackaged	5 Hz to 500 Hz, 2.20 g RMS random
ESD	+/-12 KV except I/O port +/- 8 KV per <i>Intel® Environmental Test Specification</i> .
System Cooling Requirement in BTU/Hr	1200 Watt Max – 4095 BTU/hour
	1600 Watt Max – 5459 BTU/hour

Appendix B: Regulatory and Compliance Information

Please refer to the Server Products Regulatory and Safety document for the product regulatory compliance reference. The document can be downloaded from http://www.intel.com/p/en_US/support/server/.

Appendix C: Getting Help

If you encounter an issue with your server system, follow these steps to obtain support:

1. Visit the following Intel® support web page at http://www.intel.com/p/en_US/support/server/. This web page provides 24x7 support when you need it to get the latest and most complete technical support information on all Intel® Enterprise Server and Storage Platforms. Information available at the support site includes:
 - Latest BIOS, firmware, drivers and utilities
 - Product documentation, installation and quick start guides
 - Full product specifications, technical advisories and errata
 - Compatibility documentation for memory, hardware add-in cards, chassis support matrix and operating systems
 - Server and chassis accessory parts list for ordering upgrades or spare parts
 - A searchable knowledgebase to search for product information throughout the support site
2. If you are still unable to obtain a solution to your issue, send an email to Intel®'s technical support center using the online form available at <http://supportmail.intel.com/scripts-emf/welcome.aspx>.
3. Lastly, you can contact an Intel® support representative using one of the support phone numbers available at http://www.intel.com/p/en_US/support/contact/phone (charges may apply). Intel® customer support suggests filling out the issue report form available at Appendix D: Intel® Server Issue Report Form to better service the issue.

Intel® also offers Channel Program members around-the-clock 24x7 technical phone support on Intel® server boards, server chassis, server RAID controller cards, and Intel® Server Management at <http://www.intel.com/reseller/>.

Note: You will need to log in to the Reseller site to obtain the 24x7 number.

Warranty Information

To obtain warranty information, visit the following Intel® web site:
<http://www.intel.com/support/motherboards/server/sb/cs-010807.htm>.

Appendix D: Intel® Server Issue Report Form

Issue Report Form (Rev 3.6)

Note: Filling out this form completely is required for any escalation.

Customer Contact Information:

Customer Support Case#:

Intel® Server Board or System:

(Example: S2600JF, H2216JF/H2312JF)

Server Chassis:

(Example P4000M. If third-party chassis used, indicate make and model.)

Base Board Information: (some information may be found by accessing BIOS and going through the Server Management menu > System Information)

Baseboard PBA/TA/AA # (Example: 123456-789):

- can be found on the white sticker label on the baseboard.

System BIOS Version:

Intel® Remote Management Module Firmware Version (if applicable):

Intel® Management Module BMC Revision (if applicable):

BMC/mBMC Version:

FRU/SDR Version:

HSC Version:

Has the latest BIOS been tried? (Yes/No):

Has the latest BMC/mBMC been tried? (Yes/No):

Has the latest IMM BMC been tried? (Yes/No):

Has the latest RMM Firmware been tried? (Yes/No):

Has the latest FRU/SDR been tried? (Yes/No):

Has the latest HSC been tried? (Yes/No):

Processor information:

	Type	Speed	Spec	Thermal Solution
Processor 1				
Processor 2				
Processor 3				
Processor 4				

Thermal solution (Heat sink) examples:

(1U, Passive w/air ducting, Active w/fan, and so on)

Memory:

Manufacturer	Part Number	DRAM Part Number	On Intel® tested list?

Add-in adapters (Example: NICs, Management Adapters, Serial Expansion Cards, PCI-Express* Adapters, RAID Controllers, SCSI Controllers, and so on):

Type	Slot	Manufacturer	Model	Firmware

Other third part hardware (Example: KVM, Chassis, and so on):

Appendix D: Intel® Server Issue Report Form

Description/Use	Manufacturer	Model	Firmware

Storage Devices (Example: SCSI, SATA, SAS, USB, Tape, and so on):

Manufacturer	Model	Type	Size	Firmware	In Hot Swap Bay?

Operating System Information (Example: RedHat* Enterprise Linux, Microsoft Windows Server 2003*, Service Pack 1, OEM CD):

Manufacturer:

Version:

Language version (English, Arabic, and Chinese (Simplified)):

Service Pack Level or Kernel Revision:

Distribution (OEM/Retail):

Intel® RAID Controller: (Example SRCU42E)

RAID controller part number (PBA number):

RAID controller firmware version:

Has the latest RAID firmware been tried? (Yes/No):

RAID driver version:

Has the latest RAID driver been tried? (Yes/No):

RAID volumes configuration (disks and RAID level):

RAID volume use (Boot device/Data Volume):

Is BBU (Battery Backup Unit) installed? (Yes/No):

BBU part number:

Detailed description of issue:

Troubleshooting tried:

Steps to replicate the issue:

Issue impact statements:

Do you have any potential Intel® system, or component purchases that this issue is holding up? If yes, please provide a brief description below.

Do you have systems already purchased that are not being delivered to your customers because of this issue? If yes, please provide a brief description below.

Have you returned systems or components to your place of purchase because of this issue? If yes, please provide a brief description below.

*All other brands and names are property of their respective owners.